

REQUEST FOR BID

Sauk County Buildings Services

Sauk County Fiber Optic Vault Marking Project

Wednesday, January 11th, 2023

- I. Point of contact: Ian Crammond
Sauk County Building Services
510 Broadway
Baraboo, Wisconsin 53913
(608) 355-4415

- II. Bid Due Date: Bids must be received by the County Clerk and date stamped no later than 10:00 a.m., Central Standard Time, Tuesday, January 31, 2023. Faxes and emails are not acceptable. Bids or amendments received by Sauk County after that time will not be considered. A Public Opening of Bids will be conducted on Tuesday, January 31, 2023, at 10:15 p.m. in the Sauk County Courthouse – EMBS Meeting Room (C128) at 510 Broadway, Baraboo, Wisconsin 53913.

III. **ALL PROPOSALS MUST BE ADDRESSED TO:**

**Sauk County Clerk
Sauk County West Square Building
505 Broadway
Baraboo, Wisconsin 53913**

The words "**Sauk County Fiber Optic Vault Marking Project**" must be clearly marked on the sealed envelope alongside the County's address information.

PART ONE
INTRODUCTION AND GENERAL INFORMATION

1.0 INTRODUCTION

This document constitutes a request for competitive Bids for properly mark all the Sauk County owned fiber vaults with Industry Standard Rhino Tri-View or Rhino Dome markers to include Test Station inserts at approximately 420 locations.

1.1 ORGANIZATION

2.0 This document, referred to as a Request for Bid (RFB), has been divided into the following parts for the convenience of the vendor:

- Part One - - Introduction and General Information
- Part Two - - Scope of Work –
- Part Three - - General Requirements
- Part Four - - Evaluation Information
- Part Five- - Pricing and Information

3.0 DEFINITIONS

3.1 For the purpose of this RFB the entity submitting the Bid will be referred to as Vendor and Sauk County will be referred to as County.

4.0 BACKGROUND INFORMATION

4.1 Sauk County is one of 72 units of county government in the State of Wisconsin and is a municipal corporation existing pursuant to the authority of Chapter 59 of the Wisconsin Statutes. County operations include a skilled nursing facility, a Human Services Department, a State Circuit Court System, a Highway Department, Sheriff's Department, a tax administration and collection effort, and other government related functions.

5.0 TENTATIVE SCHEDULE OF EVENTS

<u>EVENT</u>	<u>DATE</u>	<u>TIME (CST)</u>
Request for Bid released	January 11, 2023	
Pre-Bid Conference Rm 128 EMBS meeting room Sauk County Courthouse	January 18, 2023	10:00 a.m.
Bids Due	January 31, 2023	10:00 a.m.
Bids opened	January 31, 2023	10:15 a.m.
Contract Awarded by Property Committee	February 2, 2023	4:30 p.m.

Questions regarding the project can be sent to Ian Crammond at ian.crammond@saukcountywi.gov

* Responses to all questions to be e-mailed, Bid vendors shall provide e-mail address to Ian Crammond at the above referenced email address in order to receive said

6.0 OPPORTUNITY TO INSPECT

In order to fully understand the project, Bidders will have an opportunity to meet at the Sauk County Courthouse EMBS meeting room (128) located at 510 Broadway Baraboo, WI 53913 on January 18, 2023, at 10:00 a.m. Attendance is not necessary in order to bid on the project. Summarized minutes of the meeting will be circulated to attendees

Page left Intentionally Blank

PART TWO
SCOPE OF WORK

1.0 OVERVIEW

Sauk County Fiber facilities include approximately 420 underground vaults. All the vaults in the system have trace wires for the purpose of utility location. The trace wires are currently being stored inside the vaults with minimum exposure through the vault covers for connections for the location service. The vaults, when installed did not include ground rods or marking posts.

The purpose of this project is to properly mark all the Sauk County owned fiber vaults with Industry Standard Rhino Tri-View markers to include Test Station inserts at approximately 420 vault locations.

Sauk County Plans to purchase all material needed for the project to include: Fiber Marker Posts with Test Stations, ground rods and ground clamps, multiple rolls of trace wire and colored cable ties.

2.0 SPECIFICS

- 2.1. The awarded contractor will receive detailed maps of the fiber vault locations prior to project start.
- 2.2. The awarded contractor will provide the labor to install county provided Rhino Tri-View marker, grounding rod, 1” conduit sweep, test station, new wire from test station to current vault wire & vault ground rod
- 2.3. The awarded contractor will need to fulfill the following tasks at each of the approximately 420 Sauk County owned fiber vaults.
 - 1) Remove and clean away any tall grass, bushes, or general debris within a 3-foot radius around the vault.
 - 2) Remove the fiber vault cover to accomplish the following:
 - Locate the Trace wires coming from the underground fiber ducts.
 - Install the 3/2” grounding rod at attached specifications.
 - Excavate a hole large enough for the marking post on the exterior side of vault.
 - Install 1” conduit sweeps between marker post and vault interior
 - Install (level/plumb) marker Post with Test Station at attached specifications backfilling post as needed
 - Install “New” wire from Test Station to the fiber vault for each trace wire currently in the vault as well as a New Ground wire from Test Station to the vault ground rod.
 - Wire nut existing trace wires to new Test Station wire.
 - Use colored cable ties to identify the Test Station wire connection for Fiber direction.
 - Replace cover
 - Document any issues or concerns found at any particular vaults that may require addition attention.

Sauk County Wisconsin

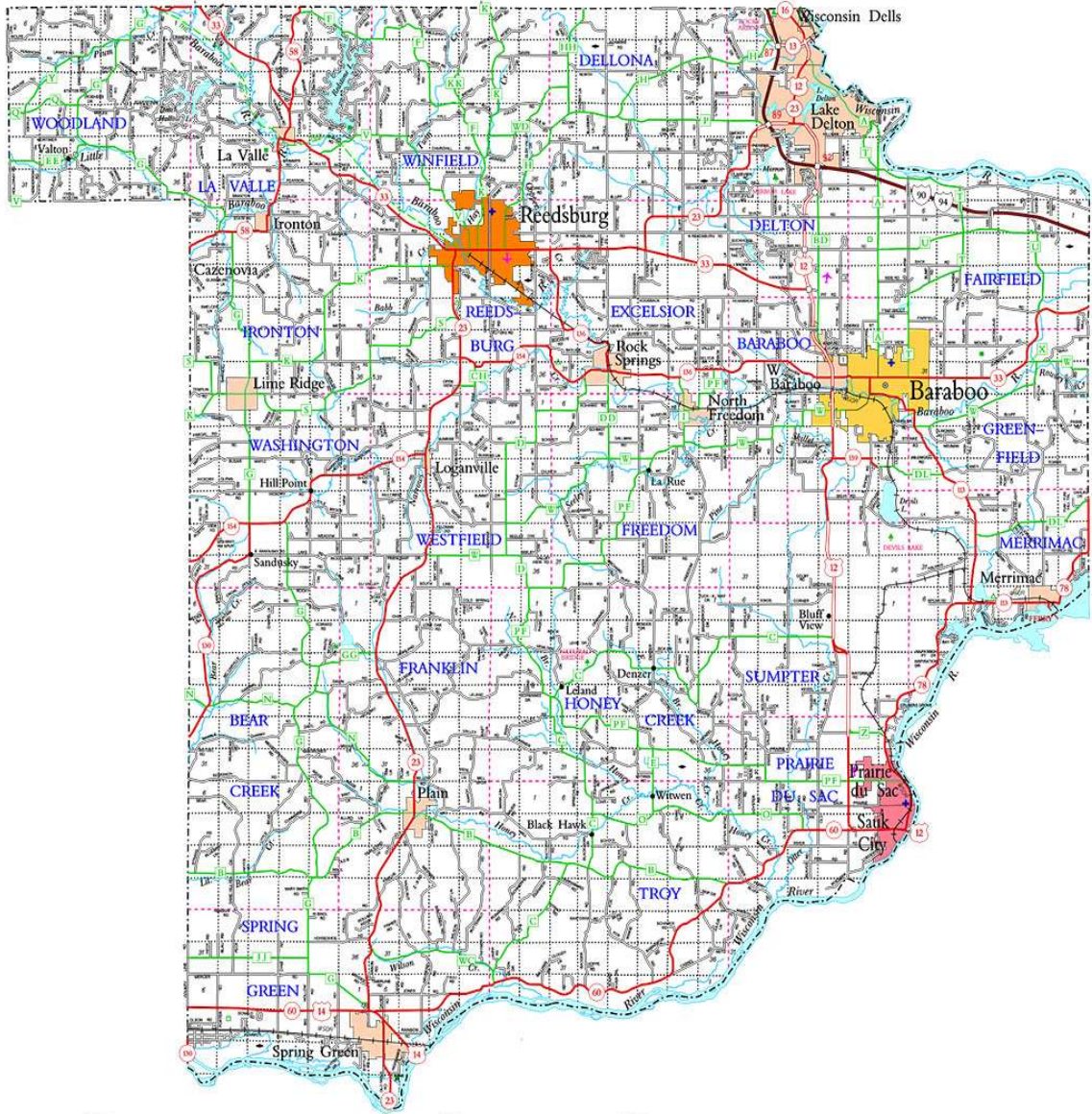

FRONT VIEW

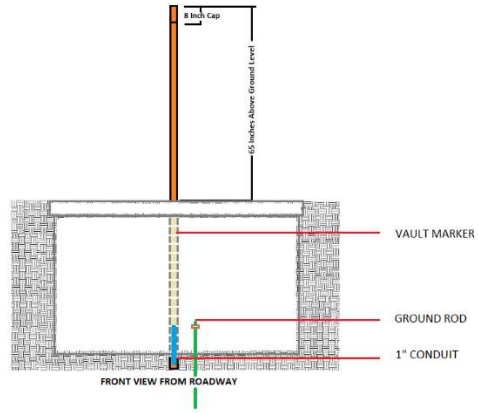

TOP VIEW

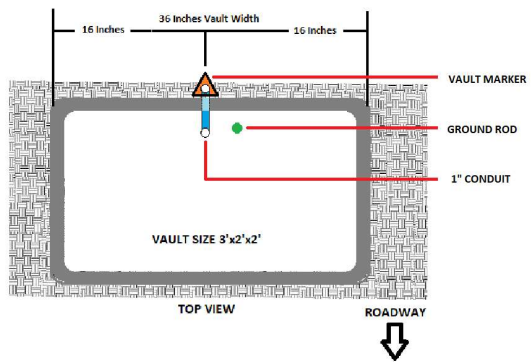

SIDE VIEW

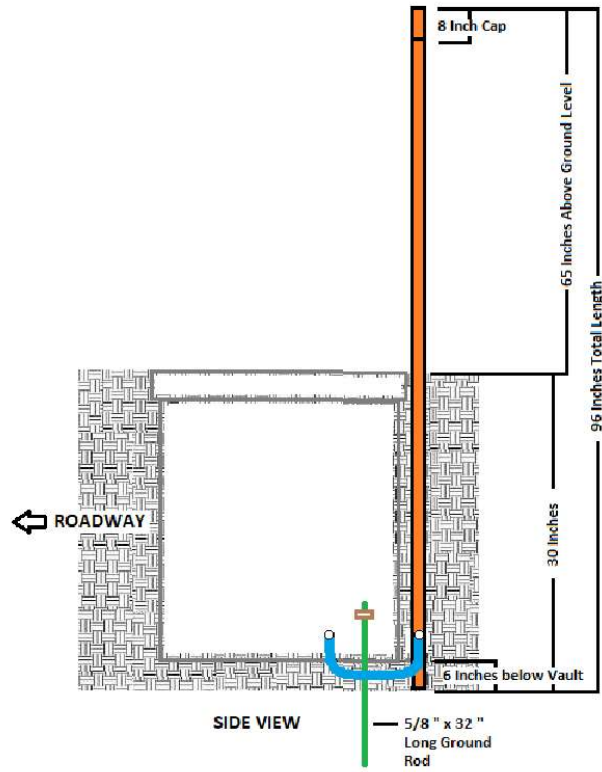

SIDE VIEW DETAILS

Sigma ProConnex 5/8" Grounding Rod Clamp or equivalent to be used for ground rod connection



Ground Rod Driven 24' into ground with 8" exposed above bottom on vault floor.

1" conduit sweeps between vault and parker post with 4" to 8" exposed above bottom of vault floor.

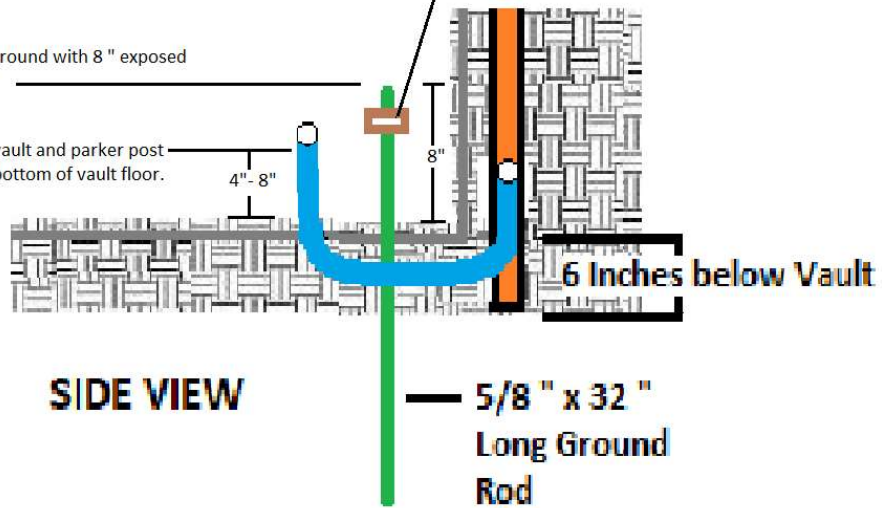

ISO-SWITCH

TOP MARKER POST ISO- SWITCH

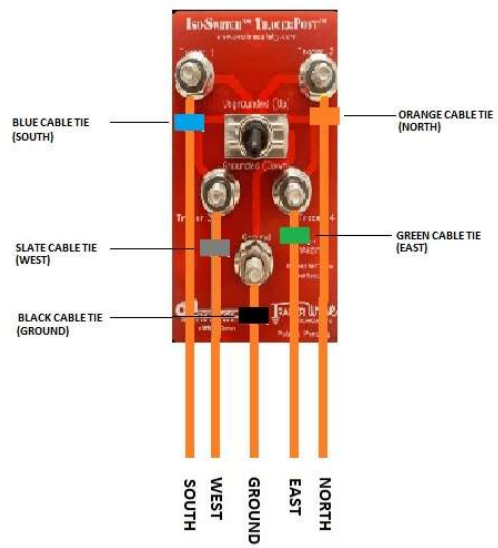

1" CONDUIT

1" conduit from fiber vault to marker post



REPORTING REQUIREMENTS

The Sauk County Fiber Optic Vault Marking project will be broken into “LEGS to complete”, meaning the sections of fiber from a specific point to another specific point that we use to identify a fiber circuit.

Those Legs are as follows:

MAIN

- 1) CH-LD - 37
- 2) LD-ZOBEL - 27
- 3) ZOBEL-HCC - 0
- 4) HCC-RDHWY - 0
- 5) RDHWY-RD - 7
- 6) RD-HH - 43
- 7) HH-HP - 46
- 8) HP-SG - 43
- 9) SG-SC - 50
- 10) SC-TR - 36
- 11) TR-LEC - 27
- 12) LEC-CH - 9

EDA SPURS

- 13) HILLPOINT - 7
- 14) IRONTON - 14
- 15) LAKE DELTON - 5
- 16) LIME RIDGE - 12
- 17) LOGANVILLE - 17
- 18) MERRIMAC – 8
- 19) NORTH FREEDOM - 6
- 20) PLAIN - 5
- 21) ROCK SPRINGS - 4
- 22) SAUK PRAIRIE - 7
- 23) SPRING GREEN - 9

Sauk County Fiber Optic Vault Marking Project REPORTING REQUIREMENTS

The awarded Contractor will be required to notify Sauk County on completion of each “LEG”. At which point the Awarded Contractor can submit an invoice for payment for the work completed. Also, at this time, any problems or issues found beyond the scope of work can be reported.

If mechanical methods of excavation are used at the vault site for the installation, the Awarded Contractor will be required to call Diggers Hotline for each vault location.

Awarded Contractor will be required to notify Sauk County of any damage that is found prior to the installation work at each site.

Awarded Contractor will be required to notify Sauk County of any Damage that is a result of the installation work at each site.

Awarded Contractor will be required to notify Sauk County of any accident to property or injury person if occurred at work site.

Sauk County will have Staff available to answer any questions remotely and be able to meet workers at vault locations if needed.

Sauk County will occasionally visit work locations to check on work progress and to answer any questions.

3.0 SCHEDULE

The work included in this request for bid shall be substantially completed by December 1, 2023. There is no specific order in which the Project Legs need to be completed.

PART THREE
GENERAL REQUIREMENTS

STANDARD TERMS AND CONDITIONS (REQUESTS FOR BID)

- 1.0 SPECIFICATIONS:** The specifications in this request are the minimum acceptable. When specific manufacturer and model numbers are used, they are to establish a design, type of construction, quality, functional capability and/or performance level desired. When alternates are proposed, they must be identified by manufacturer, stock number, and such other information necessary to establish equivalency, Sauk County shall be the sole judge of equivalency. Bidders are cautioned to avoid Bid alternates to the specifications which may result in rejection of their Bid.
- 2.0 QUALITY:** If supplies are furnished, unless otherwise indicated in the request, all material shall be first quality. Items which are used, demonstrators, obsolete, seconds, or which have been discontinued are unacceptable without prior written approval by Sauk County.
- 3.0 QUANTITIES:** The quantities shown on this request are based on estimated needs. The County reserves the right to increase or decrease quantities to meet actual needs.
- 4.0 PRICING AND DISCOUNT:** Sauk County qualifies for governmental discounts; unit prices shall reflect these discounts.
- 4.1 Unit prices shown on the Bid or contract shall be the prices per unit of sales (e.g., gal., cs., dos., ea., etc.) as stated on the request or contract. For any given item, the quantity multiplied by the unit prices shall establish the extended price. If an apparent mistake exists in the extended price, the unit price shall govern in the Bid evaluation and contract administration.
- 4.2 Prices established in continuing agreements and term contracts may be lowered due to general market conditions, but prices shall not be subject to increase for ninety (90) calendar days from the date of award. Any increase proposed shall be submitted to the contracting agency thirty (30) calendar days before the proposed effective date of the price increase and shall be limited to fully documented cost increases to the vendor, which are demonstrated to be industry wide. The conditions under which price increases may be granted shall be expressed in Bid documents and contracts or agreements.

- 5.0 ACCEPTANCE-REJECTION:** Sauk County reserves the right to accept or reject any or all Bids, to waive any technicality in any Bid submitted, and to accept any part of a Bid as deemed to be in the best interests of Sauk County.
- 5.1 Bids MUST be date stamped by Sauk County Clerk, 505 Broadway, Room 144, Baraboo, WI 53913, on or before the date and time that the Bid is due. Bids dated and time stamped in another office will be rejected. Receipt of a Bid by the mail system does not constitute receipt of a Bid by the County Clerk's office.
- 5.2 Bids shall be submitted on company letterhead and signed by an officer of the company. Mark sealed envelope: " **Sauk County Fiber Optic Vault Marking Project** " alongside the County's address information.
- 6.0 METHOD OF AWARD:** Award shall be made to the lowest responsible, responsive bidder unless otherwise specified. Sauk County reserves the right to award based upon the evaluation of the Bids, which the county deems to be in its best interest.
- 7.0 ORDERING:** Purchase order shall be placed directly to the vendor by an authorized agency. No other purchase orders are authorized.
- 8.0 PAYMENT TERMS AND INVOICING:** Sauk County normally will pay properly submitted vendor invoices within forty-five (45) days of receipt providing goods and/or services have been delivered, installed (if required), and accepted as specified.
- 9.0 TAXES:** Sauk County and its agencies are exempt from payment of all federal tax and Wisconsin state and local taxes on its purchases except Wisconsin excise tax as described below which is excepted by State Statutes.
- 9.1 Sauk County, including all its agencies, is required to pay the Wisconsin excise or occupation tax on its purchase of beer, liquor, wine, cigarettes, tobacco products, motor vehicle fuel, and general aviation fuel. However, it is exempt from payment of Wisconsin sales or use tax on its purchases. Sauk County may be subject to other states' taxes on its purchases in that state depending on the laws of that state.
- 10.0 ENTIRE AGREEMENT:** These Standard Terms and Conditions shall apply to any contract or order awarded as a result of this request except where special requirements are stated elsewhere in the request; in such cases, the special requirements shall apply. Further, the written contract and/or order with referenced parts and attachments shall constitute the entire agreement and no other terms and conditions in any document, acceptance, or acknowledgment shall be effective or binding unless expressly agreed to in writing by the contracting authority. The successful Bid/bidder will be required to sign the contract document attached hereto.
- 11.0 GUARANTEED DELIVERY:** Failure of the vendor to adhere to delivery schedules as specified or to promptly replace rejected materials shall render the vendor liable for all costs in excess of the contract price when alternate procurement is necessary. Excess costs shall include the administrative costs.
- 12.0 APPLICABLE LAW:** The vendor shall at all times comply with and observe all federal and state laws, local laws, ordinances, and regulations which are in effect during the period of this contract and which in any manner affect the work of its conduct. The Sauk County Circuit Court shall be the court of exclusive jurisdiction for any litigation between the parties arising out of the performance of this contract. This contract shall be interpreted in accordance with the laws of the State of Wisconsin.
- 13.0 ANTITRUST ASSIGNMENT:** The vendor and Sauk County recognize that in actual economic practice, overcharges resulting from antitrust violations are in fact usually borne by Sauk County (purchaser). Therefore, vendor hereby assigns to Sauk County any and all claims for such overcharges as to goods, materials or services.
- 14.0 ASSIGNMENT:** No right or duty in whole or in part of the vendor under this contract may be assigned or delegated without the prior written consent of Sauk County.
- 15.0 SUBVENDORS:** If sub-Vendors are planned to be used, this should be clearly explained in the Bid. However, the prime vendor will be responsible for contract performance whether or not sub-Vendors are used.

16.0 **Mediation.** If a dispute arises between or among the Parties, the Parties shall first proceed in good faith to submit the matter to mediation. Costs related to mediation shall be mutually shared between or among the Parties. Unless otherwise agreed in mediation. If the matter is not resolved via mediation the parties retain all rights to seek redress in the Sauk County circuit court.

17.0 **NONDISCRIMINATION:** In connection with the performance of work under this contract, the vendor agrees not to discriminate against any employee or applicant for employment because of age, race religion, color, handicap, sex, physical condition, sexual orientation, national origin, or developmental disability, as defined in s. 51.01(5), Wis. Stats. This provision shall include, but not be limited to, the following: employment, upgrading, demotion or transfer; recruitment or recruitment advertising; lay-off or termination; rates of pay or other forms of compensation; and selection for training, including apprenticeship.

17.1 Failure to comply with the conditions of this clause may result in the vendor becoming declared an "ineligible" vendor, termination of the contract, or withholding of payment.

18.0 **SAFETY REQUIREMENTS:** All employer practices, employee practices, materials, equipment, and supplies provided to Sauk County must comply fully with all safety requirements as set forth by the Wisconsin Administrative Code, Rules of the Industrial Commission on Safety, and all applicable OSHA Standards.

19.0 **WARRANTY:** Unless otherwise specifically stated by the Bid/bidder; equipment purchased as a result of this request shall be warranted against defects by the Bid/bidder for three hundred sixty-five (365) days from date of receipt. The equipment manufacturer's standard warranty shall apply as a minimum and must be honored by the vendor.

20.0 **HOLD HARMLESS:** Vendor agrees to indemnify, hold harmless, and defend Sauk County, its officers, agents and employees from any and all liability including claims, demands, losses, costs, expenses and damages of every kind arising out of or in connection with services provided pursuant to this contract where such liability is founded upon or grows out of acts or omissions of any agents or employees of the vendor.

21.0 **INSURANCE RESPONSIBILITY:** The vendor performing services for Sauk County shall:

21.1 Maintain workers compensation insurance, as required by Wisconsin Statutes, for all employees engaged in the work.

21.2 Maintain general liability and owners and vendors protection in the following amounts. Sauk County shall be named as an additional named insured:

General Liability:

General Aggregate	\$1,000,000.00
Products-Comp/Op Agg	\$1,000,000.00
Personal & Adv. Injury	\$1,000,000.00
Each Occurrence	\$1,000,000.00

Automobile: (Combined single limit) \$1,000,000.00

Excess Liability: (Umbrella) \$ 1,000,000.00. (Each occurrence and aggregate.)

21.3 Provide policy, countersigned by an insurer licensed to do business in the State of Wisconsin, covering the period of the agreement/contract indicating that Sauk County is an additional named insured on public liability, professional liability and property damage insurance required above.

21.4 Provide insurance certificates indicating required coverage, countersigned by an insurer licensed to do business in Wisconsin, covering the period of the agreement/contract. The insurance certificate is required to be presented prior to the issuance of the purchase order or before commencement of the contract.

- 22.0 CANCELLATION:** Sauk County reserves the right to cancel any contract in whole or in part without penalty due to non-appropriation of funds, or for failure of the vendor to comply with the terms, conditions, and specifications of this contract.
- 23.0 TERMINATION FOR CONVENIENCE:** Sauk County reserves the right to terminate this contract for convenience upon 90 days notice.
- 24.0 DATE OF COMPLETION:** Sauk County requires that all work under this contract shall be completed by the date of completion stated in the bid. Consideration will be given to time of completion when reviewing the submitted bids. In order to be considered a responsive bid, the bid must state a date of completion. It is Sauk County's desire to have the project substantially completed by December 1, 2023.
- 25.0 TERMINATION FOR DEFAULT:** Sauk County reserves the right to terminate this contract for default if, after twenty days written notice to cure default, vendor fails to satisfactorily cure the default.
- 26.0 AUDIT:** During the term of the contract, the vendor shall, upon the request of the Sauk County Controller, make available at reasonable times and places, such information as may be required for the purpose of auditing submitted bills for the service provided under the contract.
- 27.0 INDEPENDENT VENDOR STATUS:** None of the officers, employees, or agents of the vendor are employees of Sauk County for any purpose, including but not limited to compensation, fringe benefits, or insurance coverage.
- 28.0 PUBLIC RECORDS ACCESS:** It is the intention of the county to maintain an open and public process in the solicitation, submission, review, and approval of procurement activities.
- 28.1 Bid openings are public unless otherwise specified. Records may not be available for public inspection prior to issuance of the notice of intent to award or the award of the contract.
- 28.2 If awarded this contract, Vendor shall assist Sauk county in complying with any open records request.
- 29.0 PROPRIETARY INFORMATION:** Any restrictions on the use of data contained within a request must be clearly stated in the Bid itself. Proprietary information submitted in response to a request will be handled in accordance with applicable Sauk County procurement regulations and the Wisconsin public records law. Proprietary restrictions normally are not accepted. However, when accepted, it is the vendor's responsibility to defend the determination in the event of an appeal or litigation.
- 29.1 Data contained in a Bid, all documentation provided therein, and innovations developed as a result of the contracted commodities or services cannot be copyrighted or patented. All data, documentation, and innovations become the property of the Sauk County.
- 29.2 Any material submitted by the vendor in response to this request that the vendor considers confidential and proprietary information, and which qualifies as a trade secret, as provided in s. 19.36(5), Wis. Stats., or material which can be kept confidential under the Wisconsin public records law, must be identified. Bid prices cannot be held confidential.
- 30.0 DISCLOSURE:** If a public official (s. 19.42, Wis. Stats.), a member of the public official's immediate family, or any organization in which a public official or a member of the official's immediate family owns or controls a ten percent (10%) interest, is a party to this agreement, and if this agreement involves payment of more than three thousand dollars (\$3,000.00) within a twelve (12) month period, this contract is voidable by the County unless appropriate disclosure is made according to s. 19.45(6), Wis. Stats., before signing the contract.
- 31.0 RECYCLED MATERIALS:** Sauk County desires to purchase products incorporating recycled materials whenever technically and economically feasible. Vendors/bidders are encouraged to Bid/propose products with recycled content, which meet specifications.
- 32.0 PATENT INFRINGEMENT:** The vendor selling to Sauk County the articles described herein guarantees the articles were manufactured or produced in accordance with applicable federal labor laws. Further, that the sale or use of the articles described herein will not infringe any United States patent. The vendor covenants that it will at its own expense defend every suit which shall be brought against Sauk County (provided that such vendor is promptly notified of such suit, and all papers therein are delivered to it) for any alleged infringement of any patent by reason of the sale or use of such articles, and agrees that it will pay all costs, damages, and profits recoverable in any such suit.

- 33.0 MATERIAL SAFETY DATA SHEET:** If any item(s) on an order(s) resulting from this award(s) is a hazardous chemical, as defined under 29CFR 1910.1200, provide one (1) copy of Material Safety Data Sheet for each item with the shipped container(s) and one (1) copy with the invoice(s).
- 34.0 SUBMISSION OF SAFETY POLICIES/MANUALS.** Upon request, the vendor will be required to submit a copy of the company's safety policies and manuals to the Sauk County Buildings Services Department for review.
- 35.0 SUBSTANCE ABUSE PROGRAM.** The contractor is required to fully comply with Wis. Stat. § 103.503. This includes, but is not limited to:
- 35.1 The Contractor shall have in place a written program for the prevention of substance abuse among its employees and such written program shall be provided to Sauk County with the contract documents and before any work may be started on the project. The contents of this program shall conform to Wis. Stat. § 103.503.
- 35.2 The Contractor shall be responsible for the cost of developing, implementing, and enforcing this program as laid out in Wis. Stat. § 103.503 (3) (b).
- 36.0 PERFORMANCE BOND/PAYMENT BOND**
- 36.1 The selected Bidder shall furnish Bonds covering the faithful performance of the Contract and payment of all obligations to subcontractors and others who provide materials or labor. ("Bonds"). Bonds may be secured through the Bidder's usual source. Cost of Bonds shall be included in the Bid.
- 36.2 Both Bonds shall be written in the amount of the Contract Sum. The Bidder shall deliver the required Bonds to the Owner with the executed Contract.
- 36.3 A Surety licensed to do business in Wisconsin shall issue the Bonds. Bonds shall be dated on or after the date of the Contract.
- 36.4 If using a Power of Attorney, the Bidder shall require the Attorney-in-Fact who executes the required Bonds on behalf of the surety to affix thereto a certified and current copy of the power of attorney. It shall state the monetary limit of the power. In addition, a certified and effective dated copy of the power of attorney shall be affixed to each Bid or Bonds by the Attorney-in-Fact executing documents.
- 37.0 BID BOND.** Bids shall be accompanied by a security deposit as follows:
- 37.1 A Bid bond in the amount equal to 5% of the proposers bid. Use AIA A310 Bid Bond Form.
- 37.2 Endorse the Bid Bond in the name of the Owner as obligee, signed and sealed by the principal (Contractor) and surety.
- 37.3 The security deposit will be returned after delivery to the Owner of the required Performance and Payment Bond(s) by the accepted bidder.
- 37.4 Include the cost of bid security in the Bid Amount.
- 37.5 After a bid has been accepted, all securities will be returned to the respective bidders and other requested enclosures.
- 37.6 If no contract is awarded, all security deposits will be returned.
- 38.0 LIST OF SUBCONTRACTORS:** Bidder agrees, to the extent practicable, to maintain a list of all subcontractors, suppliers, and service providers performing, furnishing, or procuring labor, services, materials, plans, or specifications under the contract.
- 39.0 FEES FOR CHANGES IN THE WORK:** Include the following with the bid form:

39.1 The overhead and profit fees on own Work and Work by subcontractors, applicable for Changes in the Work, whether additions to or deductions from the Work on which the Bid Amount is based.

39.2 The fees proposed for subcontract work for changes (both additions and deductions) in the Work. Contractor shall apply fees as noted, to the subcontractors' gross (net plus fee) costs on additional work.

40.0 CONTRACTOR ACKNOWLEDGMENT OF STANDARD TERMS & CONDITIONS:

CONTRACTOR

AUTHORIZED SIGNATURE OF CONTRACTOR

DATE

PART FOUR
EVALUATION INFORMATION

1.0 EVALUATION PROCESS

- 1.1 The award of a contract resulting from this Request for Bid shall be based on the lowest responsible bidder in combination with the pricing.
- 1.2 In the event that only one Bid is received in response to this Request for Bid, Sauk County reserves the right to negotiate the terms and conditions, including the price, as proposed in the vendors Bid. In addition, as part of such negotiations, Sauk County reserves the right to require supporting cost, pricing and other data from the vendor in order to determine the reasonableness and acceptability of the Bid.
- 1.3 Sauk County reserves the right to reject any and all Bids or portions thereof.
- 1.4 All Vendors must provide proof of previous experience in completing similar work as it relates to the scope of work.
- 1.5 All Vendors must sign and return PART THREE of this document with their Bid.
- 1.6 All Vendors must sign and complete PART FIVE Pricing & Information document with their Bid.

PART FIVE
PRICING & INFORMATION

BASE BID: Lump sum cost to complete all work identified in PART 2 Scope of Work for the sum of:

(\$ _____)

ALTERNATE BID: Price per vault to complete all work identified in PART 2 Scope of Work for the sum of:

(\$ _____)

SAUK COUNTY PROVIDED MATERIALS

Any materials and/or services that Sauk County will need to provide to Vendor to complete this project must be listed below:

Supplies to update approximately 420 existing vaults:

- Rhino Tri-View markers Posts with Test Stations
- Ground rods and ground clamps
- Multiple rolls of trace wire
- Colored cable ties

The Vendor hereby agrees to provide the services and/or items at the prices quoted, pursuant to the requirements of this document and further agrees that when this document is countersigned by an authorized official of Sauk County, a binding contract, as defined herein, shall exist between the Vendor and Sauk County.

CONTRACTOR

AUTHORIZED SIGNATURE OF CONTRACTOR

DATE

PRINTED NAME, TITLE

SAUK COUNTY OFFICIAL

DATE

The Bidder has examined and carefully prepared the Bid from the plans and specifications and has checked the same in detail before submitting the Bid to Sauk County, including the Standard Terms and Conditions. The Vendor has had the opportunity to view the installation site and had obtained all necessary information to properly complete this bid:

(Company Name/Firm)

(Witness)

(Company Representative)

(County Representative)

(Signature)

(Signature)

STATE OF _____)

)ss.

COUNTY OF _____)

Personally came before me this _____ day of _____, 2022 , the above named _____ to me known to be the person who executed the foregoing instrument and acknowledge the same.

Signature of Notary Public

Typed or Printed Name of Notary Public
My Commission (expires) (is) _____

CONTRACT

THIS CONTRACT, made this day ____ of _____, by Sauk County hereinafter called "COUNTY" or : "OWNER" acting herein through its Building Services Department, and Furlong Industrial Systems (FIS) doing business as *(an individual) (a partnership) (a joint venture) (a corporation)(other: describe _____ located in the *(City) (County) of _____, Germantown County of Washington, and State of Wisconsin, hereinafter called "CONTRACTOR."

WITNESSETH: That for and in consideration of the payments and agreements hereinafter mentioned, to be made and performed by the COUNTY, the CONTRACTOR hereby agrees with the COUNTY to commence and complete the project described as follows: **Project (Sauk County Fiber Optic Vault Marking Project)**, hereinafter called the PROJECT, for the sum of _____ and all extra work in connection therewith, under the terms as stated in the bidding documents, specifications and contractor's bid; and at its own proper cost and expense to furnish all the materials, (except materials which the contract documents specifically require to be purchased by the County) supplies, machinery equipment, tools, superintendence, labor, insurance, and other accessories and services necessary to complete the said project in accordance with the conditions and prices stated in the Contract Documents.

The CONTRACTOR further agrees to complete the project by April 2023. A contract extension shall be at the discretion of the Facilities Director.

The COUNTY agrees to pay the CONTRACTOR in current funds for the performance of the contract, subject to additions and deductions, as provided in herein, and to make payments on account thereof as provided in the Estimates and Payments sections.

IN WITNESS WHEREOF, the parties to these presents have executed this contract in two (2) counterparts, each of which shall be deemed an original, in the year and day first above mentioned.

AGREED:

SAUK COUNTY, WISCONSIN

By: Brent Miller
County Administrator

[SIGNATURES CONTINUE ON THE NEXT PAGE]

CONTRACTOR:

By:

(Name)

(Title)

(Address)

(City and State)