

H. Declaration

By affixing our signatures below, we swear that the document above accurately portrays the relationship and intent of all parties.

FOR Sauk County	FOR Upper Sugar River Watershed Association
By:	By:
Name: _____	Name: Wade Moder _____
Signed: <u>[Signature]</u>	Signed: <u>[Signature]</u>
Title: ADMINISTRATOR _____	Title: Executive Director _____
Date Signed: 10/21/2021 _____	Date Signed: 9/09/2021 _____

By (2nd, optional):

Name: _____

Signed: _____

Title: _____

Date Signed: _____

1
2
3 **GENERAL CODE OF SAUK COUNTY, WISCONSIN**
4 **ORDINANCE AMENDMENT # 7 - 2023**
5

6 **Ordinance Amendment to approve a map amendment (rezoning) of lands in the**
7 **Town of Westfield from an Exclusive Agriculture to an Agriculture Zoning District**
8 **filed upon Elvin Yoder, property owners.**
9

10 **Ordinance Amendment offered by the Land Resources and Environment Committee**
11

12 **BACKGROUND:**
13

14 Background: Elvin Yoder owns property in the NE ¼, NW ¼, Section 26, T11N, R4E, Town
15 of Westfield, and has requested a map amendment (rezoning) of property legally
16 described pursuant to petition 11-2023 from an Exclusive Agriculture zoning district to an
17 Agriculture zoning district. The intent of the map amendment (rezoning) being create a
18 2.38 acre lot for community uses including a cemetery, school, and place of worship.
19

20 Pursuant to Wis. Stat. §59.69(5) Sauk County has the authority to develop, adopt, and
21 amend a zoning ordinance. At a public hearing held by the Land Resources and
22 Environment (LRE) Committee on September 26, 2023; the LRE Committee made
23 findings pursuant to Sauk County Code of Ordinance §7.150(9) and recommended
24 approval of the map amendment.
25

26 Pursuant to Wis. Stat. §66.1001 Wisconsin Statutes, any program or action of a local
27 governmental unit that affects land use shall be consistent with the comprehensive plan.
28 The Sauk County Comprehensive Plan, adopted by the Sauk County Board of Supervisors
29 in 2009, defines managing and focusing "on efficient land use patterns that promotes
30 redevelopment of under-utilized lands. It sets limits on outward growth, incorporates
31 permanent land preservation techniques, and achieves livable communities." Upon
32 evaluation of the request, the Land Resources and Environment Committee found that the
33 rezone request to an Exclusive Agriculture zoning district maintains this objective.
34

35 **NOW, THEREFORE, THE SAUK COUNTY BOARD OF SUPERVISORS DOES**
36 **ORDAIN AS FOLLOWS:**

37 Section 1. Any existing ordinances, codes, resolutions, or portions thereof in
38 conflict with this ordinance shall be and hereby are repealed as far as any conflict exists.

39 Section 2. This ordinance shall take effect the day after passage and publication
40 as required by law.

41 Section 3. If any claims, provisions or portions of this ordinance are adjudged
42 unconstitutional or invalid by a court of competent jurisdiction, the remainder of this
43 ordinance shall not be affected thereby.

44 Section 4. Section 7.005(2) Official Zoning Map of the General Code of Sauk
45 County, Wisconsin, is amended as follows:
46

47 Rezone of approximately 2.38 acres of tax parcel 040-0553-10000 from an Exclusive
48 Agriculture Zoning District to an Agriculture Zoning District.
49

50 Approved for presentation to the County Board by the Land Resources and Environment
51 Committee this 26th day of September, 2023.

52
53
54
55
56
57
58
59
60
61
62
63
64
65
66
67
68
69
70
71
72
73
74
75
76
77
78
79
80
81
82
83
84
85
86
87
88
89
90
91
92
93
94
95
96
97

Consent Agenda Item: [] YES [X] NO

Fiscal Impact: [X] None [] Budgeted Expenditure [] Not Budgeted

Vote Required: Majority = X 2/3 Majority = _____ 3/4 Majority = _____

The County Board has the legal authority to adopt: Yes X No _____ as reviewed by the Corporation Counsel, [Signature], Date: 10.12.2023

Offered and passage moved by:

[Signature]
MARTY KRUEGER, CHAIR Aye Nay Abstain Absent

[Signature]
PETER KINSMAN, VICE CHAIR Aye Nay Abstain Absent

[Signature]
DENNIS POLIVKA Aye Nay Abstain Absent

[Signature]
ROBERT SPENCER Aye Nay Abstain Absent

[Signature]
BRANDON LOHR Aye Nay Abstain Absent

[Signature]
LYNN EBERL Aye Nay Abstain Absent

[Signature]
VALERIE MCAULIFFE Aye Nay Abstain Absent

Fiscal Note: No Impact AMH

MIS Note: No Impact

RESOLUTION # 81-2023

Resolution to Adopt Amendments to the Land Resources and Environment Department Fee Schedule

Resolution offered by the Land Resources and Environment Committee

Resolved by the Board of Supervisors of Sauk County, Wisconsin:

BACKGROUND: Pursuant to Chapter 10 of the Sauk County Code of Ordinances, the Sauk County Board of Supervisors has the authority to establish reasonable fees for the use of Sauk County Parks. To ensure that White Mound County Park remains a destination for distinguished recreational activities, an outdoor event space fee is included, the tent set-up fee has been adjusted and a discounted rate for extra daily vehicle passes is also included.

As part of the master planning process for White Mound County Park, it was determined that Sauk County would develop rustic campsite options for visitors to utilize and would renovate and rehabilitate the horse campground. Both the rustic and horse campsites will be available for rental in 2024. No fees have been established yet for these campsites.

THEREFORE, BE IT RESOLVED, that the Sauk County Board of Supervisors, met in regular session, that the fee schedule for the Land Resources and Environment Department, pursuant to the Sauk County Code of Ordinances for Chapter 10, attached hereto as Appendix A, be approved with the amendments as shown.

Approved for presentation to the County Board by the Land Resources and Environment Committee, this 17th day of October, 2023

Consent Agenda Item: [] YES [] NO

Fiscal Impact: [] None [X] Budgeted Expenditure [] Not Budgeted

Vote Required: Majority = X 2/3 Majority = 3/4 Majority =

The County Board has the legal authority to adopt: Yes X No as reviewed by the Corporation Counsel, [Signature], Date: 10.12.2023

Offered and passage moved by:

[Signature] Marty Krueger, Chair [X] Aye [] Nay [] Abstain [] Absent

[Signature] Peter Kinsman, Vice Chair [] Aye [] Nay [] Abstain [X] Absent

[Signature] Brandon Lohr [] Aye [] Nay [] Abstain [X] Absent

[Signature] Dennis Polivka [X] Aye [] Nay [] Abstain [] Absent

52
53
54
55
56
57
58
59
60
61
62
63
64
65
66
67
68

Robert Spencer Aye Nay Abstain Absent

Valerie McAuliffe Aye Nay Abstain Absent

Lynn Eberl Aye Nay Abstain Absent

Randy Puttkamer Aye Nay Abstain Absent

Fiscal Note: Increased and new fees will result in increased revenue to cover any costs incurred by the Department for implementation of the fees and ordinances noted.

MIS Note: No impact.

dmh

PARK AND RECREATION (10-04-1) and (1) set and amended upon authorization of the County Board

Fees	Amount	Authority	As of	Comments
Camping				
Electric campsite	\$25.00	10.04	10/19/2021 (Resolution 84-2021)	Per night
Electric horse campsite	\$30.00	10.04	-	Per night
Nonelectric campsite	\$20.00	10.04	10/19/2021 (Resolution 84-2021)	Per night
Rustic campsite	\$20.00	10.04	-	Per night
Unattended electric campsite	\$10.00	10.04	10/19/2021 (Resolution 84-2021)	Per night
Unattended nonelectric campsite	\$5.00	10.04	10/19/2021 (Resolution 84-2021)	Per night
Rebooking fee	\$5.50	10.04	04/20/2021 (Resolution 42-2021)	Per reservation
Reservation fee	\$5.00	10.04	12/15/2009 (Resolution 169-2009)	Per reservation
Park Entrance				
Annual pass - 1 vehicle	\$25.00	10.04	12/15/2015 (Resolution 125-2015)	Per vehicle, per year
Annual pass - 2 vehicles	\$40.00	10.04	12/15/2015 (Resolution 125-2015)	Per vehicle, per year, only at original time of purchase
Annual pass - Veteran	\$0.00	10.04	03/22/2016 (Resolution 36-2016)	Honorably discharged, residing in Sauk County
Daily pass	\$5.00	10.04	12/15/2015 (Resolution 125-2015)	Per vehicle, per day
Ordinance violation - Failure to Prepay	\$20.00	10.04	12/20/2022 (Resolution 113-2022)	Per occurrence
Ordinance violation - Unpaid	\$25.00	10.04	12/20/2022 (Resolution 113-2022)	Per occurrence, nonpayment of failure to prepay
Equipment Rental				
Canoe	\$15.00	10.04	04/20/2021 (Resolution 42-2021)	Per hour
Kayak (double)	\$15.00	10.04	04/20/2021 (Resolution 42-2021)	Per hour
Kayak (single)	\$10.00	10.04	04/20/2021 (Resolution 42-2021)	Per hour
Paddleboard	\$15.00	10.04	04/20/2021 (Resolution 42-2021)	Per hour
Pedal boat	\$20.00	10.04	04/20/2021 (Resolution 42-2021)	Per hour
Miscellaneous Fees				
Credit card use	\$3.00	10.04	12/20/2022 (Resolution 113-2022)	Per transaction for camping reservations
Firewood	\$1.50	10.04	12/20/2022 (Resolution 113-2022)	Per transaction for all other transactions
Ice	\$5.00	10.04	12/20/2022 (Resolution 113-2022)	Per bundle
Vending machine items, shower fees	\$3.00	10.04	12/20/2022 (Resolution 113-2022)	Per bag
Promotional Items	Not to exceed \$5.00	10.04	12/20/2022 (Resolution 113-2022)	Fee will adjust depending on the expense cost.
Prairie Smoke Terrace				
Prairie Smoke Terrace	Not to exceed \$30.00	10.04	02/21/2023 (Resolution 6-2023)	Fee will adjust depending on the expense cost.
Daily Rental	\$200.00	10.04	03/15/2022 (Resolution 32-2022)	Per four (4) hours
Additional hour(s)	\$50.00	10.04	03/15/2022 (Resolution 32-2022)	Per hour
3-day Package	\$800.00	10.04	03/15/2022 (Resolution 32-2022)	8 am-12 pm; 8 am-11pm; 8am-12pm
Security deposit	\$300.00	10.04	03/15/2022 (Resolution 32-2022)	Per daily rental(s)
Security deposit	\$500.00	10.04	03/15/2022 (Resolution 32-2022)	Per 3-day Package rental(s)
Tent set-up	\$100.00 \$50.00	10.04	03/15/2022 (Resolution 32-2022)	3-day Package rental required
Outdoor event space	\$50.00	10.04	12/20/2022 (Resolution 113-2022)	Prairie Smoke Terrace rental required
Additional daily vehicle passes	\$75.00	10.04	-	Prairie Smoke Terrace rental required, .25 extra passes

RESOLUTION # 82 - 2023

1
2
3 **Resolution to adopt the Sauk County Farm Education Hub Development Plan as an**
4 **Appendix to the 2022-2042 Sauk County Farm Property Master Plan in the County**
5 **CORP.**

6
7 **Resolution offered by the Land Resources and Environment Committee**

8
9 Resolved by the Board of Supervisors of Sauk County, Wisconsin:

10
11 **BACKGROUND:**

12 The Sauk County Land Resources and Environment Department created the 2022-2042 Sauk
13 County Farm Property Master Plan to ensure the continued management of the site's
14 agricultural and natural resources, preservation of its historic features, and the transformation
15 of the space into an educational resource for the communities of Sauk County. Over the next
16 20 years, the County Farm is envisioned to become an important educational resource for
17 Sauk County residents of all ages and backgrounds to learn about regenerative, profitable,
18 and resilient agricultural practices through on-site demonstration, research and collaborative
19 partnerships. The master plan is centered on the following goals: to create educational
20 opportunities for Sauk County's current and future farmers through community partnerships;
21 utilize the space for agricultural demonstration and research; and pay homage to the history
22 and people of the property. The County Farm will become a space where educational
23 institutions, non-profit organizations, public agencies, and any interested person in Sauk
24 County can converge to learn about farming and train the leaders who will carry forward our
25 community's agricultural legacy.

26
27 Resolution No. 150-2019 adopting the 2020-2024 Sauk County Outdoor Recreation Plan was
28 approved by the Sauk County Board of Supervisors on January 21, 2020. As part of the
29 Master Plan process for the Sauk County Farm, an area was designated as a future
30 educational hub for indoor/outdoor events, programming, recreational trails, community
31 gardens, and habitat restoration. As part of the 2023 LRE Budget, \$75,000 of general funds
32 were included for the design of this area. Resolution No. 17-2023 awarded a contract for
33 design and engineering services of the educational hub at the Sauk County Farm.

34
35 The Sauk County Farm Property Master Plan and development plan for the education hub
36 intersects with the following priorities and objectives of the Sauk County Outdoor Recreation
37 Plan; priority: further development of the County Park System, objectives: develop master
38 plans for Sauk County properties; priority: resource management and stewardship, objective:
39 community education, and improved water quality; priority: partnerships, objectives: intersect
40 with other units of government and non-government organizations (NGOs), and leverage
41 recreational and planning grants; priority: economic development and tourism.

42
43 **THEREFORE, BE IT RESOLVED,** that the Sauk County Board of Supervisors, met in
44 regular session, does hereby adopt the Sauk County Education Hub Development Plan
45 attached hereto as Appendix A as an appendix to the 2022-2042 Sauk County Farm
46 Property Master Plan in the County CORP.

47
48 Approved for presentation to the County Board by the Land Resources and Environment
49 Committee, this 17 day of October, 2023

50
51 Consent Agenda Item: [] YES [] NO

52
53
54
55
56
57
58
59
60
61
62
63
64
65
66
67
68
69
70
71
72
73
74
75
76
77
78
79
80
81
82
83
84
85
86
87
88
89
90
91
92
93
94
95
96
97

Fiscal Impact: [] None [X] Budgeted Expenditure [] Not Budgeted

Vote Required: Majority = X 2/3 Majority = _____ 3/4 Majority = _____

The County Board has the legal authority to adopt: Yes X No _____ as reviewed by the Corporation Counsel, *[Signature]*, Date: 10.12.2023

Offered and passage moved by:

[Signature] Aye Nay Abstain Absent
Marty Krueger, Chair

_____ Aye Nay Abstain Absent
Peter Kinsman, Vice Chair

_____ Aye Nay Abstain Absent
Brandon Lohr

[Signature] Aye Nay Abstain Absent
Dennis Polivka

[Signature] Aye Nay Abstain Absent
Robert Spencer

[Signature] Aye Nay Abstain Absent
Valerie McAuliffe

[Signature] Aye Nay Abstain Absent
Lynn Eberl

_____ Aye Nay Abstain Absent
Randy Puttkamer

Fiscal Note: The LRE 2023 Budget includes donation funds in the amount of \$4,055 for the maintenance of the area surrounding the historic 1921 fire house located on the property. The budget also includes \$24,000 in farm revenue funds for pasture expansion and installation of educational signed on the property. Any additional improvements outlined in the Master Plan would be reviewed in future budget cycles along with pursuing grants. *JMH*

MIS Note: The property would require the installation and maintenance of a wireless internet connection upon construction of the educational building. This will be reviewed in future budget cycles.

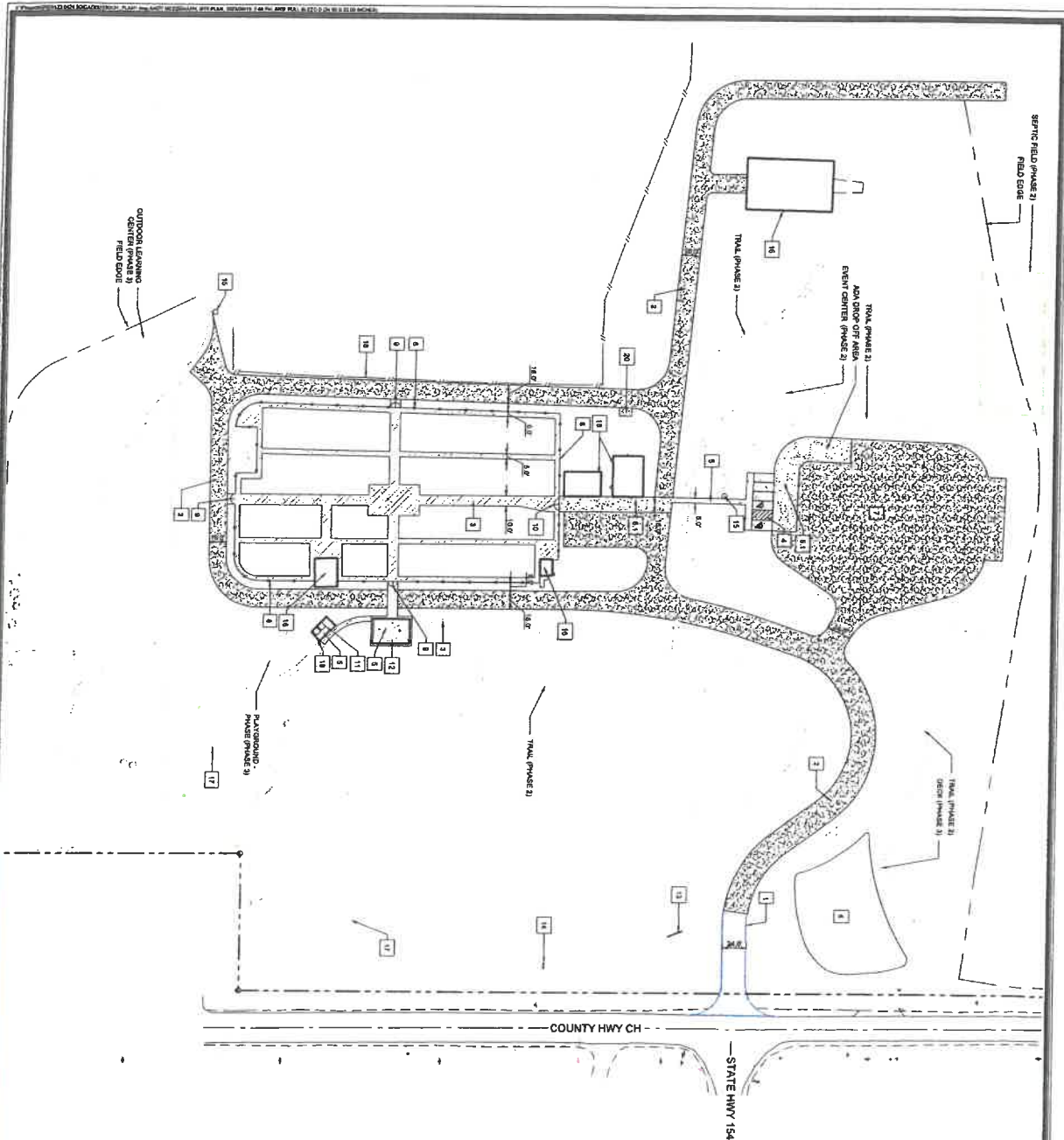

PHASE 1 SITE KEYNOTES

- 1 ASPHALT ENTRANCE DRIVE
- 2 GRAVEL DRIVE
- 3 CRUSHED AGGREGATE TRAIL
- 4 ADA STAIRS
- 5 8" CONCRETE PATH OR PAD
- 6 4" CONCRETE PATH OR PAD
- 7 IMPERMEABLE AREA
- 8 1.5" x 8" STAIRS
- 9 1.5" x 8" STAIRS
- 10 1" DEEP FENCE
- 11 1" DEEP FENCE
- 12 1" DEEP FENCE
- 13 1" DEEP FENCE
- 14 1" DEEP FENCE
- 15 1" DEEP FENCE
- 16 1" DEEP FENCE
- 17 1" DEEP FENCE
- 18 1" DEEP FENCE
- 19 1" DEEP FENCE
- 20 1" DEEP FENCE

PHASE 1 LEGEND

- ASPHALT
- GRAVEL
- 8" THICK CONCRETE
- 4" THICK CONCRETE
- 1" THICK CRUSHED AGGREGATE TRAIL
- 1" DEEP FENCE
- EXISTING FENCE TO REMAIN

NOT FOR CONSTRUCTION

CALL DIGGERS HOTLINE
1-800-242-8511
TOLL FREE

TO OBTAIN LOCATION OF PARTICIPANTS UNDERGROUND DIO IN WISCONSIN
 WIS. STATUTE 182.075 (1974)
 REQUIRES MIN. OF 3 WORK DAYS NOTICE BEFORE YOU EXCAVATE

SAUK COUNTY FARM EDUCATION HUB - PHASE 1		TOWN OF REEDSBURG, SAUK COUNTY, WISCONSIN	
SITE PLAN		REVISION	
SNYDER & ASSOCIATES, INC.		DATE BY	
609 VOICES ROAD MADISON, WISCONSIN 53718 608-326-0444 www.snyder-associates.com		Engineer: SJA	Checked By: ATM
Project No: 123,0424_30		Technician: ADB	Date: 09-07-2023
Scale: 1" = 50'		7-R-3, T1234-FINAL-03A	
Sheet C300		Sheet C300	

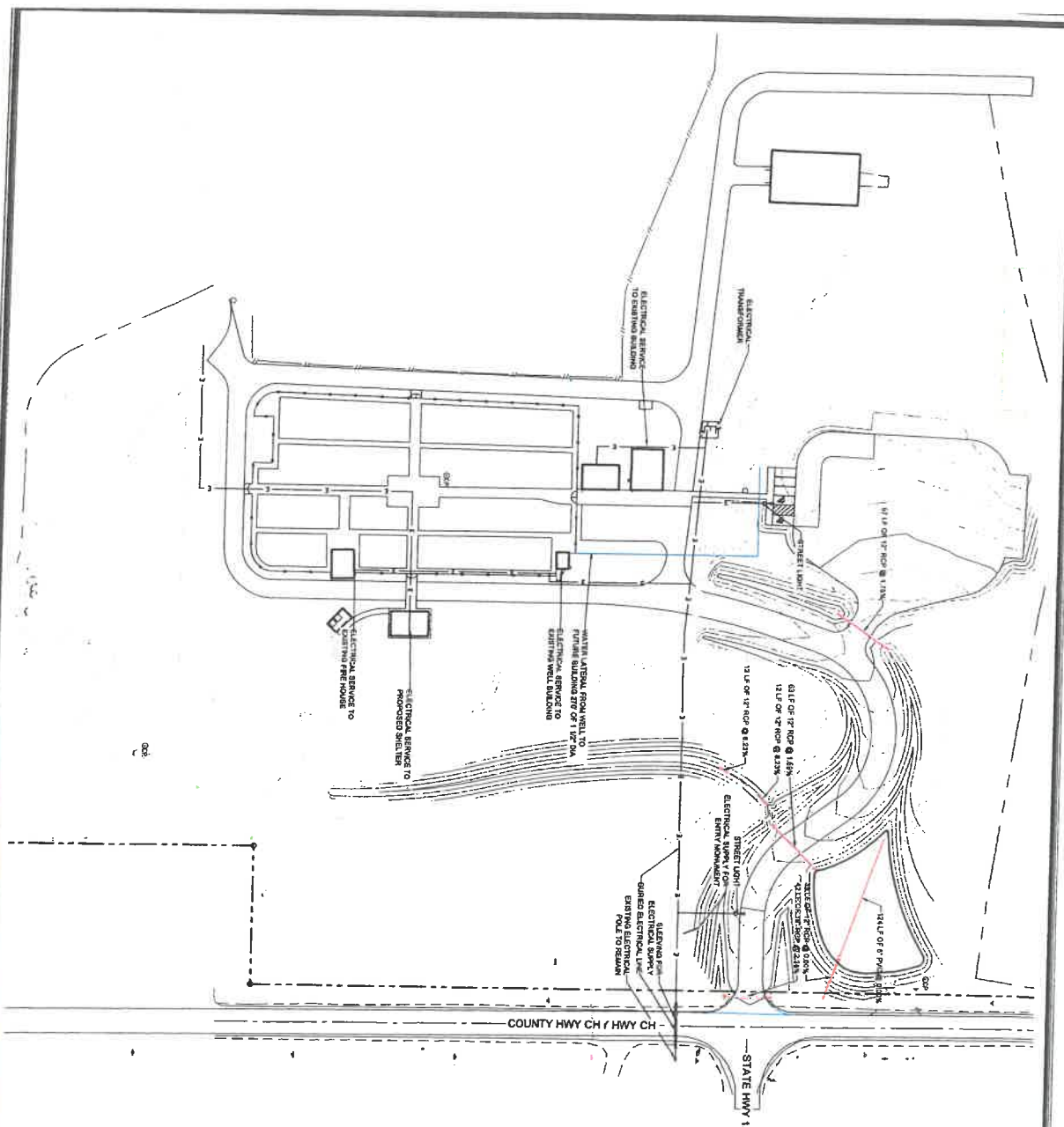

- WATER DISTRIBUTION NOTES**
1. THE WATER DISTRIBUTION SYSTEM SHALL BE DESIGNED TO SERVE THE ENTIRE PROJECT AREA. THE WATER DISTRIBUTION SYSTEM SHALL BE DESIGNED TO SERVE THE ENTIRE PROJECT AREA. THE WATER DISTRIBUTION SYSTEM SHALL BE DESIGNED TO SERVE THE ENTIRE PROJECT AREA.
 2. THE WATER DISTRIBUTION SYSTEM SHALL BE DESIGNED TO SERVE THE ENTIRE PROJECT AREA. THE WATER DISTRIBUTION SYSTEM SHALL BE DESIGNED TO SERVE THE ENTIRE PROJECT AREA. THE WATER DISTRIBUTION SYSTEM SHALL BE DESIGNED TO SERVE THE ENTIRE PROJECT AREA.
 3. THE WATER DISTRIBUTION SYSTEM SHALL BE DESIGNED TO SERVE THE ENTIRE PROJECT AREA. THE WATER DISTRIBUTION SYSTEM SHALL BE DESIGNED TO SERVE THE ENTIRE PROJECT AREA. THE WATER DISTRIBUTION SYSTEM SHALL BE DESIGNED TO SERVE THE ENTIRE PROJECT AREA.
 4. THE WATER DISTRIBUTION SYSTEM SHALL BE DESIGNED TO SERVE THE ENTIRE PROJECT AREA. THE WATER DISTRIBUTION SYSTEM SHALL BE DESIGNED TO SERVE THE ENTIRE PROJECT AREA. THE WATER DISTRIBUTION SYSTEM SHALL BE DESIGNED TO SERVE THE ENTIRE PROJECT AREA.
 5. THE WATER DISTRIBUTION SYSTEM SHALL BE DESIGNED TO SERVE THE ENTIRE PROJECT AREA. THE WATER DISTRIBUTION SYSTEM SHALL BE DESIGNED TO SERVE THE ENTIRE PROJECT AREA. THE WATER DISTRIBUTION SYSTEM SHALL BE DESIGNED TO SERVE THE ENTIRE PROJECT AREA.
 6. THE WATER DISTRIBUTION SYSTEM SHALL BE DESIGNED TO SERVE THE ENTIRE PROJECT AREA. THE WATER DISTRIBUTION SYSTEM SHALL BE DESIGNED TO SERVE THE ENTIRE PROJECT AREA. THE WATER DISTRIBUTION SYSTEM SHALL BE DESIGNED TO SERVE THE ENTIRE PROJECT AREA.
 7. THE WATER DISTRIBUTION SYSTEM SHALL BE DESIGNED TO SERVE THE ENTIRE PROJECT AREA. THE WATER DISTRIBUTION SYSTEM SHALL BE DESIGNED TO SERVE THE ENTIRE PROJECT AREA. THE WATER DISTRIBUTION SYSTEM SHALL BE DESIGNED TO SERVE THE ENTIRE PROJECT AREA.
 8. THE WATER DISTRIBUTION SYSTEM SHALL BE DESIGNED TO SERVE THE ENTIRE PROJECT AREA. THE WATER DISTRIBUTION SYSTEM SHALL BE DESIGNED TO SERVE THE ENTIRE PROJECT AREA. THE WATER DISTRIBUTION SYSTEM SHALL BE DESIGNED TO SERVE THE ENTIRE PROJECT AREA.
- STORM DRAINAGE NOTES:**
1. THE STORM DRAINAGE SYSTEM SHALL BE DESIGNED TO SERVE THE ENTIRE PROJECT AREA. THE STORM DRAINAGE SYSTEM SHALL BE DESIGNED TO SERVE THE ENTIRE PROJECT AREA. THE STORM DRAINAGE SYSTEM SHALL BE DESIGNED TO SERVE THE ENTIRE PROJECT AREA.
 2. THE STORM DRAINAGE SYSTEM SHALL BE DESIGNED TO SERVE THE ENTIRE PROJECT AREA. THE STORM DRAINAGE SYSTEM SHALL BE DESIGNED TO SERVE THE ENTIRE PROJECT AREA. THE STORM DRAINAGE SYSTEM SHALL BE DESIGNED TO SERVE THE ENTIRE PROJECT AREA.
 3. THE STORM DRAINAGE SYSTEM SHALL BE DESIGNED TO SERVE THE ENTIRE PROJECT AREA. THE STORM DRAINAGE SYSTEM SHALL BE DESIGNED TO SERVE THE ENTIRE PROJECT AREA. THE STORM DRAINAGE SYSTEM SHALL BE DESIGNED TO SERVE THE ENTIRE PROJECT AREA.
 4. THE STORM DRAINAGE SYSTEM SHALL BE DESIGNED TO SERVE THE ENTIRE PROJECT AREA. THE STORM DRAINAGE SYSTEM SHALL BE DESIGNED TO SERVE THE ENTIRE PROJECT AREA. THE STORM DRAINAGE SYSTEM SHALL BE DESIGNED TO SERVE THE ENTIRE PROJECT AREA.
 5. THE STORM DRAINAGE SYSTEM SHALL BE DESIGNED TO SERVE THE ENTIRE PROJECT AREA. THE STORM DRAINAGE SYSTEM SHALL BE DESIGNED TO SERVE THE ENTIRE PROJECT AREA. THE STORM DRAINAGE SYSTEM SHALL BE DESIGNED TO SERVE THE ENTIRE PROJECT AREA.
 6. THE STORM DRAINAGE SYSTEM SHALL BE DESIGNED TO SERVE THE ENTIRE PROJECT AREA. THE STORM DRAINAGE SYSTEM SHALL BE DESIGNED TO SERVE THE ENTIRE PROJECT AREA. THE STORM DRAINAGE SYSTEM SHALL BE DESIGNED TO SERVE THE ENTIRE PROJECT AREA.
 7. THE STORM DRAINAGE SYSTEM SHALL BE DESIGNED TO SERVE THE ENTIRE PROJECT AREA. THE STORM DRAINAGE SYSTEM SHALL BE DESIGNED TO SERVE THE ENTIRE PROJECT AREA. THE STORM DRAINAGE SYSTEM SHALL BE DESIGNED TO SERVE THE ENTIRE PROJECT AREA.
 8. THE STORM DRAINAGE SYSTEM SHALL BE DESIGNED TO SERVE THE ENTIRE PROJECT AREA. THE STORM DRAINAGE SYSTEM SHALL BE DESIGNED TO SERVE THE ENTIRE PROJECT AREA. THE STORM DRAINAGE SYSTEM SHALL BE DESIGNED TO SERVE THE ENTIRE PROJECT AREA.

NOT FOR CONSTRUCTION

TO OBTAIN LOCATION OF PARTICIPANTS UNDERGROUND SERVICES IN WISCONSIN
 CALL DIGGERS HOTLINE
 1-800-242-8811
 TOLL FREE
 MS. STAFF: 182.0175 / (919) 709-2123
 HOURS: MON. - FRI. 8:00 AM - 5:00 PM
 HOURS: SAT. 9:00 AM - 1:00 PM

SAUK COUNTY FARM EDUCATION HUB - PHASE 1
UTILITY PLAN
 TOWN OF REEDSBURG, SAUK COUNTY, WISCONSIN

SNYDER & ASSOCIATES, INC.

5616 VOEGES ROAD
 MADISON, WISCONSIN 53718
 608-838-0444 | www.snyder-associates.com

NO.	DATE	BY	REVISION
1			
2			
3			
4			
5			
6			
7			
8			
9			
10			

Project No: 123,0424.30
 Sheet C402



SAUK COUNTY

FARM EDUCATION HUB

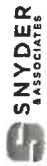

HISTORY PASTURE CROPLAND NATIVE
a place to converge, learn, and demonstrate with regenerative agriculture and conservation-friendly farming best practices.



- LEGEND**
- 1 - EXISTING SHED TO REMAIN
 - 2 - EXISTING CENTER BUILDING
 - 3 - EVENT CENTER BUILDING
 - 4 - EVENT LAWN AND OVERFLOW PARKING
 - 5 - SEPTIC FIELD
 - 6 - COME L. WALKING LOT - AS STALLS
 - 7 - SWALE
 - 8 - DEMO PLOTS
 - 9 - HORSE/STEW HOUSE
 - 10 - HORSE STABLE
 - 11 - HORSE STABLE
 - 12 - HORSE STABLE
 - 13 - ASPHALT ROAD
 - 14 - ENTRY MONUMENT
 - 15 - EXISTING CATTLE FENCE TO REMAIN
 - 16 - EXISTING CATTLE FENCE TO REMAIN
 - 17 - GATE
 - 18 - CONTING WALK TO REMAIN
 - 19 - PICKING TABLE SPACE
 - 20 - COMMUNITY GARDENS
 - 21 - EXISTING PASTURE TO REMAIN
 - 22 - FENCE
 - 23 - BLEETER
 - 24 - OPEN LAWN
 - 25 - PLAYGROUND
 - 26 - PLAYGROUND
 - 27 - PARKER
 - 28 - STONE WALK
 - 29 - STONE WALK
 - 30 - JERMANIA GARDEN
 - 31 - OPEN LAWN W/ PICKING WALKER
 - 32 - OUTDOOR LEARNING CENTER
 - 33 - TRAIL/BIKESHOOR

PLAN VIEW



PROJECT DESCRIPTION

Wagon in the Sauk County Farm, a 50-acre property comprised of cropland, pasture, wooded, wetlands and trees. The site is located in the center of the area which contains the far remnants of the Neumann legacy. The Sauk County LBE Department has created a 20-year master plan for the County Farm to transform the space into an educational resource for the community. The plan includes an agricultural farm, natural resources, and the preservation of its history and historic features. The farm will be developed into an educational hub, featuring an agricultural demonstration plot, prime restoration, educational building, outdoor learning space, remedial site, and agricultural operation. The completed project will continue to be rented out to event farmers, and will be used for educational purposes. The County Farm is envisioned to become an important educational resource for Sauk County residents at all ages. The County Farm will be managed by the County Farm, which will be a partnership between the County, the County Farm, and collaborative partners. The County Farm will become a space where educational resources, research, and collaborative partnerships. The County Farm will become a space where educational resources, research, and collaborative partnerships. The County Farm will become a space where educational resources, research, and collaborative partnerships.

POLLINATORS



PRAIRIE PLANTS



OUTDOOR LEARNING CENTER

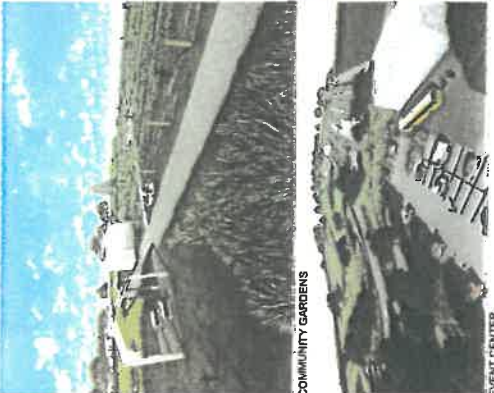

COMMUNITY GARDENS

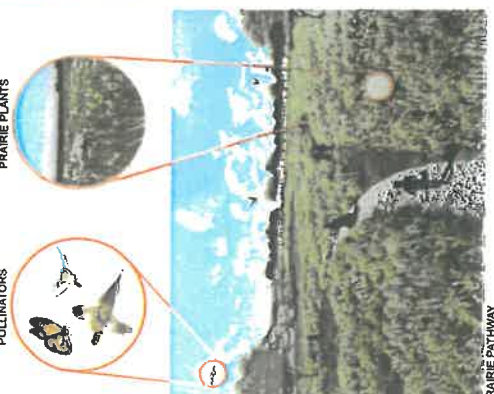

PRAIRIE PATHWAY



EVENT CENTER



ENTRY MONUMENT

RESOLUTION # 83 - 2023

Resolution Approving a Request to Apply for Cooperative County and Ho-Chunk Nation Law Enforcement Program for Tribal Trust Lands within Sauk County.

Resolution offered by the Law Enforcement and Judiciary Committee

Resolved by the Board of Supervisors of Sauk County, Wisconsin:

BACKGROUND:

This is an annual Resolution that allows us to apply for funding for our patrolling costs of the Ho-Chunk lands. Sauk County has federally recognized Ho-Chunk Nation Trust Lands having significant Wisconsin Ho-Chunk population within the borders. The State and County of Sauk have joint responsibility for providing law enforcement aid under Wis. Stat. § 165.90 to help defray the cost of services provided on Indian trust lands.

THEREFORE, BE IT RESOLVED, that the Sauk County Board of Supervisors, met in regular session, and directs the Sauk County Sheriff's Department to make application to the State of Wisconsin, Department of Justice, for aid in the amount not to exceed the limit to defray costs to enforce the laws of the State of Wisconsin on Indian trust lands in the County of Sauk and to administer such grant monies under the grant guidelines.

Approved for presentation to the County Board by the Law Enforcement & Judiciary Committee, this 17th day of October, 2023

Consent Agenda Item: [] YES [x] NO

Fiscal Impact: [] None [X] Budgeted Expenditure [] Not Budgeted

Vote Required: Majority = x 2/3 Majority = _____ 3/4 Majority = _____

The County Board has the legal authority to adopt: Yes x No _____ as reviewed by the Corporation Counsel, [Signature], Date: 10.11.2023

Offered and passage moved by:

[Signature] Aye [] Nay [] Abstain [] Absent

John Dietrich Aye [] Nay [] Abstain [] Absent

[Signature] Aye [] Nay [] Abstain [] Absent

Kevin Schell Aye [] Nay [] Abstain [] Absent

[Signature] Aye [] Nay [] Abstain [] Absent

Delmar Scanlon Aye [] Nay [] Abstain [] Absent

51 _____ Aye Nay Abstain Absent
52
53 David Clemens

54
55
56 Fiscal Note:
57 Actual revenues received were \$22,670 in 2023; \$24,500 was the amount that was included in
58 the 2024 proposed budget. *JMA*
59
60 MIS Note: No MIS impact.

1
2
3
4
5
6
7
8
9
10
11
12
13
14
15
16
17
18
19
20
21
22
23
24
25
26
27
28
29
30
31
32
33
34
35
36
37
38
39
40
41
42
43
44
45
46
47
48
49
50

RESOLUTION # **84-2023**
January 4

RESOLUTION TO RATIFY THE ~~JULY 1, 2021~~ ^{January 4} - DECEMBER 31, 2023^v COLLECTIVE BARGAINING AGREEMENT BETWEEN SAUK COUNTY AND THE WISCONSIN PROFESSIONAL POLICE ASSOCIATION (WPPA) L241 – SHERIFF’S DEPARTMENT SWORN UNIT

Resolution offered by the Personnel and Insurance Committee

Resolved by the Board of Supervisors of Sauk County, Wisconsin:

BACKGROUND: The existing collective bargaining agreement between Sauk County and WPPA L241 (Sheriff’s Department Sworn Unit) expires on December 31, 2023. The Personnel and Insurance Committee has negotiated a tentative agreement with WPPA L241 (attached hereto), for the terms of a successor agreement for the calendar dates of January 1, 2024 through December 31, 2026. In accordance with Wisconsin Act 10, certain sworn law enforcement officers maintained collective bargaining rights pursuant to Wis Stats. 111.70/111.77.

The provisions of the tentative agreements reflect a commitment of Sauk County to remain competitive with the wage rates of neighboring counties, and the dedication of both parties to recruit and retain the highest quality employees for Sauk County. Therefore, the Personnel and Insurance Committee, after careful consideration and review, believes the provisions of the tentative agreement as being in the best interest of Sauk County.

NOW, THEREFORE, THE SAUK COUNTY BOARD OF SUPERVISORS DOES ORDAIN AS FOLLOWS: The Sauk County Board of Supervisors met in regular session, that the Sauk County Personnel and Insurance Committee be and hereby is authorized and directed to sign on behalf of Sauk County a collective bargaining agreement incorporating the provisions of the tentative agreement, set forth in more detail in the attached summary.

Approved for presentation to the County Board by the Personnel and Insurance Committee this 17th day of October 2023.

Consent Agenda Item: [] YES [] NO

Fiscal Impact: [] None [X] Budgeted Expenditure [] Not Budgeted

Vote Required: Majority = X 2/3 Majority = _____ 3/4 Majority = _____

The County Board has the legal authority to adopt: Yes X No _____ as reviewed by the Corporation Counsel, *[Signature]*, Date: 10.11.2023.

Offered and passage moved by:

[Signature]
Supervisor Carl Gruber Aye Nay Abstain Absent

51
52
53
54
55
56
57
58
59
60
61
62
63
64
65
66



Supervisor Terry Spencer

Aye Nay Abstain Absent



Supervisor Peter Kinsman

Aye Nay Abstain Absent



Supervisor Robert Prosser

Aye Nay Abstain Absent

Supervisor Jake Roxen

Aye Nay Abstain Absent

Fiscal Note:

In progress!

MIS Note: No MIS Impact

**SAUK COUNTY OFFER
TO
WISCONSIN PROFESSIONAL POLICE ASSOCIATION
LAW ENFORCEMENT EMPLOYEE RELATIONS
LOCAL 241
September 5, 2023**

The July 1, 2021 - 2023 Collective Bargaining Agreement shall remain unchanged for a three-year period commencing January 1, 2024 except as follows:

Deletions are indicated by: ~~Strikethrough~~

Additions and new language indicated by: Shadow

1. Fair and equitable wage increase effective the first pay period to include January 1, 2024.
 - a. Effective January 1, 2024, 6.0% on all rates and increase Step 5 (8 years) by \$.50;
 - b. Effective January 1, 2025, 6.0% on all rates and increase Step 5 (8 years) by \$.50;
 - c. Effective January 1, 2026, 6.0% on all rates and increase Step 5 (8 years) by \$.25.

4.06 COLLECTIVE BARGAINING. If collective bargaining sessions are conducted for a successor agreement during the normal working hours of bargaining committee members at the request of the Employer, up to five (5) such members from separate divisions (~~patrol, jail and detective~~), with a maximum of two (2) per division, shall suffer no reduction in pay for up to five (5) bargaining sessions. TA 9/20/2023

7.01 - NON-DISCRIMINATION. The Employer and the Union agree that there shall be no discrimination against any employees or prospective employees because of race, creed, color, age, sex/gender, national origin, sexual orientation, ancestry, marital status, gender identity, genetic testing, pregnancy or childbirth, military service, ~~handicapping conditions~~ disability, or any other characteristic protected by state or federal law. It is and shall be the policy of the Employer and the Union to treat all employees equally. Because discrimination complaints are processed through state and federal agencies and courts, they are not grievable under this agreement. TA 8/22/2023

9.02 - JOB POSTINGS. The Employer agrees that when a position becomes available that would be a promotional opportunity for existing employees, the following steps shall be followed:

1. Vacancies shall be posted.
2. Qualified existing employees shall be allowed to take any accredited tests given for said position.
3. Existing employees shall be given preference in filling open positions over external applications, all other things being equal.

All vacant sworn bargaining unit positions not filled by the posting process shall be filled from an established position eligibility list in accordance with the provisions set forth by the Human Resources Department.

The Employer further agrees that when a position becomes available that is an opportunity for an existing employee to change a shift assignment, the following steps shall be followed:

1. Vacancies shall be posted.

SAUK COUNTY RESERVES THE RIGHT TO ADD TO, DELETE FROM, AND/OR OTHERWISE MODIFY ANY OF THESE PROPOSALS DURING THE COURSE OF NEGOTIATIONS WITHOUT PREJUDICE. EACH ELECTED OFFICIAL RESERVES THE RIGHT TO VOTE AS THEY DEEM APPROPRIATE IN CONSIDERATION OF THE RATIFICATION OF ANY TENTATIVE AGREEMENT BROUGHT BEFORE THE COUNTY BOARD

2. Qualified existing employees shall be allowed to express their interest in vacancy.
3. Vacancy shall be filled with the senior qualified bidder from employees within the classification and division. Thereafter remaining vacancies shall be posted and shall be filled with the most senior qualified bidder within the balance of the sworn bargaining unit.

Furthermore: Any employee posting into another position classification shall remain on the step they are on when moving into the new position.

The Sheriff reserves the right to post vacant positions externally in conjunction with the language contained in Article 9.02. The Electronic Monitoring Deputy position shall be appointed by the Sheriff.

~~The Employer agrees that when a regular position authorized by Sauk County, becomes vacant and is not refilled through the bidding process, the notice of the job opening shall be posted and qualified employees shall be allowed to take any accredited tests given for said position, and existing employees shall be given preference in making promotions, all other things being equal. Vacancies shall be posted first and shall be filled with the senior qualified bidder from employees within the classification and division. Thereafter remaining vacancies shall be posted and shall be filled with the most senior qualified bidder within the balance of the sworn bargaining unit. All vacant sworn bargaining unit positions not filled by the posting process shall be filled from an established position eligibility list in accordance with the provisions set forth in Chapter 13 of the Sauk County Code of Ordinances. Furthermore: Any employee posting into another position classification shall remain on the step they are on when moving into the new position.~~

The Sheriff reserves the right to post vacant positions externally in conjunction with the language contained in Article 9.02. TA 8/22/2023

10.04 CALL-IN. All employees covered by this Agreement shall respond to a call to work outside of their regular schedule of hours, by their department head or others designated by the department head. A minimum of two (2) hours at time and one-half (1 1/2) times pay shall be granted to any employee who is requested to report outside his/her regular schedule of hours or who reports to work as scheduled and is sent home... TA 8/22/2023

10.06 - SHIFT DIFFERENTIAL. Sauk County agrees that a shift differential shall be paid as follows, except for employees who are working in accordance with a regular shift which starts after 6:00 AM and finishes by 5:00 PM; ~~any employee actually working between 2:30 PM and 11:00 PM shall receive an additional twenty cents (\$.20) per hour; any employee actually working a regular shift starting at or after 10:30 PM, or otherwise actually working after 11:00 PM, shall receive an additional twenty five cents (\$.25) per hour from such time until 7:00 AM (or 9:00 AM for an employee working a regular shift lasting until 9:00 AM) for hours actually worked.~~ The additional amount paid as shift differential shall not be pyramided in any manner.

2:30pm – 11:00pm – shall receive ~~an additional \$.20~~ per hour
 10:30pm – 7:00am* – shall receive ~~an additional \$.25~~ per hour
 Night Shift A and B (5:00pm-5:00am/6:00pm-6:00am) – shall receive ~~an additional \$.25~~ per hour
 Noon – Midnight – Patrol shall receive ~~an additional \$.20~~ per hour TA 9/5/2023

10.08 TWELVE (12) HOUR SHIFT SCHEDULE/ROTATION. Members of the patrol division shall have a 12-hour shift schedule/rotation. The 12-hour shift schedule/rotation shall consist of four (4) teams. [Days A, Days B, Nights A, Nights B] Days A and B will work a split shift of [5am-5pm/6am-6pm] and Nights A and B will work a split shift of [5pm-5am/6pm-6a m]. Days A and B and Nights A and B

SAUK COUNTY RESERVES THE RIGHT TO ADD TO, DELETE FROM, AND/OR OTHERWISE MODIFY ANY OF THESE PROPOSALS DURING THE COURSE OF NEGOTIATIONS WITHOUT PREJUDICE. EACH ELECTED OFFICIAL RESERVES THE RIGHT TO VOTE AS THEY DEEM APPROPRIATE IN CONSIDERATION OF THE RATIFICATION OF ANY TENTATIVE AGREEMENT BROUGHT BEFORE THE COUNTY BOARD

schedules shall be opposite "days-on" and "days-off" from each other on the following fourteen (14) day rotation:

a. 2 on- 2 off/ 3 on- 2 off/ 2 on-3 off during a 14-day cycle (i.e., Mon-Tues ON-- Weds-Thurs OFF / Fri-Sat-Sun ON - Mon-Tues OFF/ Wed-Thurs ON-Fri-Sat-Sun OFF)

b. An officer's "shift working date" is the actual date the shift begins.

c. One eight (8) - hour day will be implemented into the fourteen (14) day rotation for each Deputy. This 8-hour day will be flexible for training, special team call outs and other assignments. Management reserves the right to adjust the 8-hour day with a five (5) day notice. Management will assign the short days.

~~d. Shift Differential: Night Shift A and B [5pm -5a m/6pm -6a m] shall receive shift differential (\$.25 cents an hour) as provided for in Article 10, Section 10.06.~~

d. Excluding exigent circumstances, deputies shall take a minimum of eight (8) continuous hours of rest in each 24-hour period. TA 9/5/2023

10.09 ORDER-INS. When staffing levels for the patrol and security division are below the number deemed necessary for any reason, including but not limited to: staffing shortages, immediate emergency shortages, special events, etc. and the needs are not met voluntarily, these patrol division call in lists will be utilized for order-in.

Patrol Division - Order-in procedures will follow as:

- a. Each shift and stack will be an exclusive order-in list. (Days A, Days B, Nights A, Nights B).
- b. Order-ins for deputies will be rotating based on reverse seniority in their designated stacks.
- c. Deputies are subject to order-ins on their regular days off.
- d. Deputies can fulfill their "turn" in the order-in rotation by volunteering or being ordered to work a minimum of 2 hours in a patrol function. This does not include volunteering for special details.
- e. Deputies will get one "Pass" per calendar year

Security Division - All posted and voluntary overtime will be filled on a straight seniority basis. A Deputy volunteering for a full shift will be given preference over partial shift volunteers. It is understood that occasionally situations occur requiring management to immediately fill staffing needs and proceed straight to the order-in procedure.

Order-in procedures for the security division will follow as:

- a. Each shift will be an exclusive order-in list.
- b. Order-in's for Deputies will be rotating, based on reverse seniority, on their assigned shift.
- c. Deputies can fulfil their turn and drop to the bottom of the order-in rotation, by volunteering or being ordered to work a minimum of 2 hours. This does not include volunteering for special details.
- d. Credit for volunteering, or being ordered, does not accumulate and only serves to move the Deputy to the bottom of the order-in rotation.

SAUK COUNTY RESERVES THE RIGHT TO ADD TO, DELETE FROM, AND/OR OTHERWISE MODIFY ANY OF THESE PROPOSALS DURING THE COURSE OF NEGOTIATIONS WITHOUT PREJUDICE. EACH ELECTED OFFICIAL RESERVES THE RIGHT TO VOTE AS THEY DEEM APPROPRIATE IN CONSIDERATION OF THE RATIFICATION OF ANY TENTATIVE AGREEMENT BROUGHT BEFORE THE COUNTY BOARD

- e. Deputies will get 2 passes per calendar year; one pass may be utilized January thru June and the second pass may be utilized July thru December.
- f. Deputies newly assigned to a shift will be placed at the top of the order-in rotation.

While Security Deputies will be provided access to view the order-in lists and may assist in making calls for overtime/order-in, any modifications to the lists will be made by Security Division Supervisors. Deputies are responsible for notifying their supervisor about credit for overtime worked. TA 9/5/2023

10.10 CANINE HANDLER SCHEDULE. ~~The canine handler(s) shall end assigned shifts one (1) hour earlier for each 12 hour shift in order to work an eleven (11) hour shift to accommodate care of K-9. The canine handler(s) shift shall be shortened by one (1) hour at the beginning or end of the shift shall end assigned shifts one (1) hour earlier for each eight (8) hour shift worked in order to work a seven (7) hour shift to accommodate care of K-9.~~ TA 9/5/2023

11.02 - VACATION AND COMPENSATORY TIME APPROVAL....

b. Vacation or compensatory time off days in the detective division may be approved for up to two (2) employees total at the discretion of the division head, or their designee, and with that availability of personnel and overtime costs being recognized as managerial concerns. It is understood that, while management may not always be able to grant every request, no other criteria will be arbitrarily introduced as deciding factors in the vacation approval decision making process. The Sheriff or designee may approve more than two (2) employees for vacation or compensatory time off days on a case by case basis in considering the reasonableness and need for the request.

~~granted to one employee within the division, per shift, on the same date(s) at the discretion of the immediate supervisor. ...~~

d. In the Patrol Division, vacation leave may be used in increments up to and including twelve (12) hours. Between Labor Day and Memorial Day, when one employee is already approved for vacation, a second employee may be considered for vacation time. The second employee shall request vacation per departmental procedures and shall be notified of the status of the request within four (4) calendar weeks of the request. Management retains the right to recall the vacation approval within forty-eight (48) hours of the shift start. Employee's immediate supervisor may honor requests upon shorter notice, if possible. No vacation will be granted on weekends from the Friday of Memorial Weekend to the Monday of Labor Day Weekend with the exception of up to three (3) 12-hour days which shall be taken consecutively ~~one (1) 12-hour day~~ per employee. For the purpose of this agreement, weekends are defined as Friday starting at 5 AM until Monday at 5:00 AM. TA 9/5/2023

11.04 - HOLIDAY DURING A VACATION.

- a. If a holiday falls during the vacation period, an employee will be compensated for the holiday and not use a day of vacation. ~~extra day of vacation will be granted...~~ TA 8/22/2023

SAUK COUNTY RESERVES THE RIGHT TO ADD TO, DELETE FROM, AND/OR OTHERWISE MODIFY ANY OF THESE PROPOSALS DURING THE COURSE OF NEGOTIATIONS WITHOUT PREJUDICE. EACH ELECTED OFFICIAL RESERVES THE RIGHT TO VOTE AS THEY DEEM APPROPRIATE IN CONSIDERATION OF THE RATIFICATION OF ANY TENTATIVE AGREEMENT BROUGHT BEFORE THE COUNTY BOARD

12.02 SICK LEAVE CREDIT. For any employee hired after December 31, 2023. Sick Leave Credits may be accrued as follows:

- 1) All Sheriff's Department employees being represented for whom vacation periods are provided shall be given sick leave with pay at the rate of one (1) day, or eight (8) hours, of sick leave for each completed calendar month of compensated service. The term "each completed calendar month of compensated service" shall be construed to mean any calendar month in which the employee has completed thirteen (13) days of compensated service. This definition applies to all employees of the Sheriff's Department engaged in service of the County except part-time and seasonal employees or employees who are on a per diem basis. Upon the completion of the first six months of continuous employment, employees of this bargaining group may utilize accrued sick leave balances. Members of the Patrol Division may use sick leave in increments up to and including twelve (12) hours.
- 2) No employee shall be credited with an accumulation of more than one hundred and twenty (120) days of sick leave credits at any time. Employees regularly working the twelve (12) hour rotation shall not exceed 1,020 hours in their accrual bank. No employee shall be permitted to take more than one hundred and twenty (120) days of sick leave in any one (1) calendar year. Employees shall not be required to use sick leave in case of an on-the-job injury. Any employee having unused sick leave on the date of retirement, provided the employee has reached age fifty (50) if employed in a protective occupation as classified by the Wisconsin Retirement System, or age fifty-five (55) if employed in a non-protective occupation as classified by the Wisconsin Retirement System, and the employee qualifies for an annuity under the Wisconsin Retirement System, shall be able to either:
 - a. All employees shall be able to receive seventy (70.0%) of the cash value of the employee's accrued sick leave paid to the employee less applicable deductions; or,
 - b. All employees shall be eligible to convert seventy (70.0%) thereof to participate in a Health Reimbursement Arrangement (HRA). ~~purchase continuing health insurance under the County's Employee Health Insurance Plan; or,~~
 - ~~c. The employee may, at his/her discretion, receive one hundred percent (100%) the cash value of the conversion privilege in lieu of any right to further participation in the County's Employee Health Insurance Plan; the choice is irrevocable and must be made upon notice of intent to retire...~~

For any employees hired before January 1, 2024. Sick Leave Credits may be accrued as follows:

- 1) All Sheriff's Department employees being represented... TA 9/5/2023

12.05 - BEREAVEMENT LEAVE. Employees shall be entitled to bereavement leave to attend an event related to the death of an employee's spouse, child (including an unborn child after 20 weeks of gestation), parent, brother, sister, stepparent, stepchild, mother-in-law, father-in-law, son-in-law, daughter-in-law, brother-in-law, sister-in-law, grandparent, grandparent of spouse, or grandchild. In the event an employee's circumstances, familial relationships or other personal circumstances are unique and not addressed in this bereavement leave policy yet warrant time as anticipated by this policy, the Sheriff or Chief Deputy may grant an exception... TA 9/5/2023

SAUK COUNTY RESERVES THE RIGHT TO ADD TO, DELETE FROM, AND/OR OTHERWISE MODIFY ANY OF THESE PROPOSALS DURING THE COURSE OF NEGOTIATIONS WITHOUT PREJUDICE. EACH ELECTED OFFICIAL RESERVES THE RIGHT TO VOTE AS THEY DEEM APPROPRIATE IN CONSIDERATION OF THE RATIFICATION OF ANY TENTATIVE AGREEMENT BROUGHT BEFORE THE COUNTY BOARD

12.09 - JURY DUTY/SUBPOENAED WITNESS LEAVE. ~~Employees called for jury duty or as a subpoenaed witness shall be entitled to receive lost pay provided they deposit any compensation received for such duty, excluding mileage allowance, with the Employer and receive a receipt for said deposit. Employees called for jury duty or as a subpoenaed witness shall be entitled to receive compensation equal to what the employee would have earned if not called for jury duty provided that the employee deposits any compensation received for such duty, excluding mileage allowance, with the Finance Department, and receive a receipt for said deposit. TA 8/22/2023~~

14.11 TRAVEL TIME. The parties recognize that employees may be required to attend mandatory training. As used in this section, mandatory training means any training that the employee is ordered by Sheriff's Department Administration to attend. ~~The Sheriff's Department recognizes one-hour commute as a normal commute time and such~~ The parties agree that travel time will be paid for all travel that requires more than one-hour travel time each way, not just for the driver. For training that is expected to last more than one day, Administration shall decide whether an employee will stay overnight or travel to and from home during the mandatory training. Travel time is calculated as the time from the Law Enforcement Center to the training location. TA 8/22/2023

14.12 CREDIT FOR EXPERIENCE (LATERAL EMPLOYMENT). New employees hired into sworn law enforcement positions may be given credit for pay and vacation relevant police/law enforcement experience upon hire at the discretion of the Employer.

Beginning on the first pay period of 2024 (or date of contract ratification if contract is approved after that date), employees who were previously hired at a higher rate of pay (lateral for pay only) will begin accruing vacation at a rate commensurate with their total years of recognized service (prior years of recognized law enforcement experience added to the current length of employment). This change will affect the accrual rate and will not be retroactive.

14.13 DETECTIVE DIVISION ON-CALL PROCEDURES. To ensure adequate and appropriate response to emergencies and criminal investigations, all detectives for the Sauk County Sheriff's Department will rotate through an on-call schedule established by department administration. The on-call schedule will assign individual detectives to provide coverage during times when determined an on-call detective is needed. One detective will be on call at a time. If additional detectives are necessary, call-in or order-in procedures will be followed.

a. On-call shifts are defined as:

- i Weekdays: Weekdays are Monday through Thursday starting 8:00PM 6:00PM until 8:00AM, the following day. Exact hours may be revised based upon scheduling needs and other factors.
- ii Weekends: Weekends are 8:00PM 6:00PM Friday, through 8:00AM, Monday. Exact hours may change dependent on available on-duty detectives. Unless staffing adjustments occur by a supervisor, weekend on-call shifts shall be defined as:

- a. Friday: Friday 6:00PM through Saturday 8:00AM
- b. Saturday: Saturday 8:00AM through Sunday 8:00AM

SAUK COUNTY RESERVES THE RIGHT TO ADD TO, DELETE FROM, AND/OR OTHERWISE MODIFY ANY OF THESE PROPOSALS DURING THE COURSE OF NEGOTIATIONS WITHOUT PREJUDICE. EACH ELECTED OFFICIAL RESERVES THE RIGHT TO VOTE AS THEY DEEM APPROPRIATE IN CONSIDERATION OF THE RATIFICATION OF ANY TENTATIVE AGREEMENT BROUGHT BEFORE THE COUNTY BOARD

- c. Sunday: Sunday 8:00AM through Monday 8:00AM
- d. Weekend on-call order-ins will be done so by individual dates, in succession. A detective will not be ordered in for on-call coverage for the entire consecutive set of weekend days.

iii Holiday(s) are those Holiday(s) identified in Article 11.08 of the contract, for those employees who work the 5-day schedule. Exact dates and hours for Holiday(s) may vary but in most cases, consist of a 24-hour period beginning at 8:00AM and ending at 8:00AM the following day.

iv The detective division shall have an "order-in" list to fill vacancies for staffing shortages, immediate emergency shortages, special events, etc. and the needs are not met voluntarily, the detective division call-in list will be utilized for order-in. This list will also be utilized to fill vacant on-call shifts. The order-in procedures for detectives will follow as:

- a. Order-ins for detectives will be done by reverse seniority.
- b. Detectives are subject to order-ins on their regular days off.
- c. Detectives can fulfill their "turn" in the order-in rotation by volunteering or being ordered to cover a vacant "on-call" shift. This does not include volunteering for special details. Credit for volunteering, or being ordered, does not accumulate and only serves to move the detective to the bottom of the order-in rotation.
- d. If a detective is on a full vacation or a full comp time on any day leading up to or immediately after a vacant order-in day, that detectives shall be exempt from that specific order in day, or set of days (i.e. a weekend including Saturday or Sunday), but shall not be skipped entirely, and be subject to the next order in.
- e. Detectives will get one "pass" per calendar year
 - i. If a detective is geographically, physically, or otherwise legitimately unable to respond as determined by the division head or his designee, such event shall not constitute as a "pass".
- f. If a detective volunteers or uses their "pass" their spot on the order-in list shall be documented as a such, and their name shall be moved to the bottom of the order-in list.
- g. It is understood that occasionally situations occur requiring management to immediately fill staffing needs and proceed straight to the order-in procedure.
- h. While detectives will be provided access to view the order-in lists, any modifications to the lists will be made by a detective supervisor.

b. On-call compensation is in addition to benefits enumerated in the collective bargaining agreement. On-call compensation may not be exchanged for compensatory time.

SAUK COUNTY RESERVES THE RIGHT TO ADD TO, DELETE FROM, AND/OR OTHERWISE MODIFY ANY OF THESE PROPOSALS DURING THE COURSE OF NEGOTIATIONS WITHOUT PREJUDICE. EACH ELECTED OFFICIAL RESERVES THE RIGHT TO VOTE AS THEY DEEM APPROPRIATE IN CONSIDERATION OF THE RATIFICATION OF ANY TENTATIVE AGREEMENT BROUGHT BEFORE THE COUNTY BOARD

c. Switching on-call shift assignments: Switching on-call shift assignments must be approved by the Division Sergeant or Lieutenant. If a switch is authorized, the trade dates must be established in writing.

d. Detectives that are on-call status must be available for calls. They must be accessible through the Communication Center by cell phone or radio. Detectives who are on-call, must be "in service" no later than 45 minutes after notification. An on-call detective must be fit for duty. An on-call detective may use their vehicle for personal use during their on-call status, as authorized by the Sheriff.

e. When an on-call detective is in service, that detective will receive their hourly overtime rate, and the on-call pay rate will be suspended until the detective ends their active duty status. At that time, they will again begin receiving on-call pay until relieved of their on-call responsibility,

f. Request to be relieved of on-call duty status must be made to the division lieutenant or designee. ~~On-call~~ On-call status will be maintained until the detective is notified that he/she has been relieved from ~~on-call~~ on-call status. The vacant position will be offered starting with the most senior employee within the Division on a rotating basis. Should all employees decline, a detective will be ordered to on-call status with the least senior employee in the Division on a rotating basis.

g. The detectives that are not on-call will still be required to carry their cell phones while off duty in the event that additional detectives are needed to assist the on-call detective, or for other incidents or investigations.

h. Activation of the on-call detective remains the sole responsibility of the Department's Administration and may not be initiated by the on-call detective alone.

i. Compensation.

- i The hourly rate for weekday on-call status is ~~\$1.50~~ \$2.00.
- ii The hourly rate for weekend on-call status is ~~\$1.75~~ \$2.25.
- iii The hourly rate for Holiday on-call status is ~~\$2.00~~ \$2.50. TA 9/5/2023

SAUK COUNTY RESERVES THE RIGHT TO ADD TO, DELETE FROM, AND/OR OTHERWISE MODIFY ANY OF THESE PROPOSALS DURING THE COURSE OF NEGOTIATIONS WITHOUT PREJUDICE. EACH ELECTED OFFICIAL RESERVES THE RIGHT TO VOTE AS THEY DEEM APPROPRIATE IN CONSIDERATION OF THE RATIFICATION OF ANY TENTATIVE AGREEMENT BROUGHT BEFORE THE COUNTY BOARD

Fiscal Note:

	<u>2024</u> 92	<u>2025</u> 92	<u>2026</u> 92
Full-Time Equivalents			
Wages, Overtime with Across-the-Board (ATB) Change	\$ 6,530,747	\$ 7,005,769	\$ 7,542,823
Wage-Related Benefits with ATB (FICA/Medicare, Retirement, Work Comp)	1,494,235	1,654,763	1,835,923
Health & Life Insurance	985,716	1,063,484	1,168,638
Total Package Cost With Cost of Living Adjustment	\$ 9,010,697	\$ 9,724,016	\$ 10,547,385
Change from Prior Year Dependent on This Action			
Wages, Overtime with Across-the-Board (ATB) Change	7.5%	7.3%	7.7%
Wage-Related Benefits with ATB (FICA/Medicare, Retirement, Work Comp)	12.6%	10.7%	10.9%
Total Change from Prior Year Dependent on This Action	8.4%	7.9%	7.4%
Health (2024=+6.50%, 2025=+7.90%, 2026=9.90%) & Life Insurance (increase not dependent on this action)	6.5%	7.9%	9.9%
Total Change from Prior Year	8.2%	7.9%	8.5%
Changes include:			
1/1/2024 +6.00% on all rates and \$0.50 on Step 5, and increase in On Call Pay			
1/1/2025 +6.00% on all rates and \$0.50 on Step 5, and increase in On Call Pay			
1/1/2026 +6.00% on all rates and \$0.25 on Step 5, and increase in On Call Pay			
No MIS impact			

RESOLUTION # 85 - 2023

Resolution to Purchase land at 616 Linn St. Baraboo, WI 53913 for future use by Sauk County and Amend the 2023 Budget

Resolution offered by the Property Committee and Finance Committee

Resolved by the Board of Supervisors of Sauk County, Wisconsin:

BACKGROUND:

The family of Everest Sonsalla reached out to the county to see if there was an interest by the county to purchase the property at 616 Linn St. The property .52 acres in size and is surrounded by county owned property. The Property Committee ordered an appraisal of the property in August of 2022. The market value of the house is \$205,000. The property committee asked the Sauk County Corporation Counsel to negotiate the price not to exceed \$205,000 with the realtor. The original offer was not accepted, and the house stayed on the market for about a year. The realtor for the family reached back out to the Sauk County Corporation Counsel to see if the county was still interested in purchasing the property. The Property Committee again met and offered the original price, and the offer of \$205,000 was accepted.

THEREFORE, BE IT RESOLVED, that the County Board authorizes the purchase of 616 Linn St. Baraboo WI 53913, specifically described as the Southeast quarter of the Northwest quarter (SE-NW), of section thirty-four (34), township twelve (12), North of Range Six E (6E) containing .52 acres in size, at a cost of \$205,000; and

BE IT FURTHER RESOLVED, that All documentation related to the purchase of the property will be signed by the County Administrator and County Clerk.

Approved for presentation to the County Board by the Property Committee and Finance Committee, this 17th, day of October 2023

Consent Agenda Item: [] YES [] NO

Fiscal Impact: [] None [] Budgeted Expenditure [X] Not Budgeted

Vote Required: Majority = _____ 2/3 Majority = X 3/4 Majority = _____

The County Board has the legal authority to adopt: Yes X No _____ as reviewed by the Corporation Counsel, _____, Date:

10.12.2023

[Handwritten signature]

Offered and passage moved by Property Committee:

Carl Gruber [Handwritten signature] [X] Aye [] Nay [] Abstain [] Absent

Mark "Smooth" Dettler [] Aye [] Nay [] Abstain [] Absent

52
53
54
55
56
57
58
59
60
61
62
63
64
65
66
67
68
69
70
71
72
73
74
75
76
77
78
79
80
81
82
83
84
85
86
87

Joe Chrisler Aye Nay Abstain Absent
 Joe Chrisler
Robert Spenger Aye Nay Abstain Absent
 Robert Spenger
Mike Anderson Aye Nay Abstain Absent
 Mike Anderson

Finance Committee:

Martin F. Krueger Aye Nay Abstain Absent
 Martin F. Krueger
Thomas Dorner Aye Nay Abstain Absent
 Thomas Dorner
Lynn Eberl Aye Nay Abstain Absent
 Lynn Eberl
Richard "Mike" Flint Aye Nay Abstain Absent
 Richard "Mike" Flint
Timothy McCumber Aye Nay Abstain Absent
 Timothy McCumber

Fiscal Note: Funds for the purchase of 616 Linn St. Baraboo, WI 53913 will be taken from the General Fund Balance. The 2023 Sauk County sales tax collection is projected to be greater than budgeted, the excess collection will be moved to General Fund Balance. The remaining General Fund Balance after the \$205,000 assignment is well above the amount required by Sauk County's working capital policy

AMT

MIS Note: None

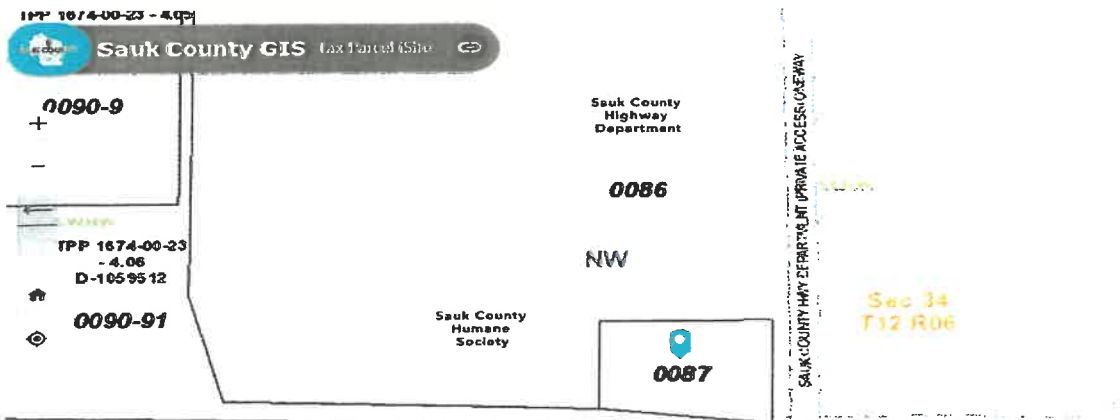

88

89



90

MINUTES

SAUK COUNTY BOARD OF SUPERVISORS

NOVEMBER 14, 2023

WEST SQUARE BUILDING, 505 BROADWAY, ROOM 326, BARABOO, WI

6:00 PM – PUBLIC HEARING ON PROPOSED 2024 SAUK COUNTY BUDGET

Pursuant to Wis. Stats. § 65.90, for the purpose of soliciting comments from the public regarding the 2024 Sauk County Budget.

1. CONVENE PUBLIC HEARING ON THE PROPOSED 2024 SAUK COUNTY BUDGET

Tim McCumber, County Board Chair.

2. BUDGET PRESENTATION

Brent Miller, County Administrator and Lynn Horkan, Finance Director.

3. PUBLIC COMMENT REGARDING THE PROPOSED 2024 SAUK COUNTY BUDGET – 3 MINUTE LIMIT

Mark Greenwood, re: Budget.

4. CLOSE PUBLIC HEARING

Tim McCumber, County Board Chair.

5. ADJOURN PUBLIC HEARING

Tim McCumber, County Board Chair.

MOTION (Detter/Klitzke) to adjourn the public hearing @ 6:26 P.M. Motion carried unanimously.

ANNUAL MEETING: SAUK COUNTY BOARD OF SUPERVISORS

1. Call to Order and Certify Compliance with Open Meeting Law: 6:26 P.M.

2. Roll Call. PRESENT: (31) Roxen, T. Spencer, Eberl, Rego, Kinsman, Klitzke, Scanlon, Anderson, Krueger, Flint, Clemens, Prosser, Lombard, Schell, Dorner, Fordham, Astle, Hazard, R. Spencer, Carver, Polivka, Burchill, Peper, Lohr, Gruber, Detter, Chrisler, Stehling, McAuliffe, Deitrich and McCumber. **ABSENT:** (0).

Staff present: Brent Miller, County Administrator; Brian Desmond, Corporation Counsel; Becky Evert, Sauk County Clerk; Cora McDonnell, Deputy County Clerk; and Michelle Commings, Deputy County Clerk.

3. Invocation and Pledge of Allegiance. Invocation given by Supr. Deitrich

4. Adopt Agenda. MOTION (Carver/T. Spencer) to adopt the agenda, removing item 10b.

~~b. Sauk County Library Board~~

~~—James Astle, District #18 Supervisor~~

~~—Term: 11/14/2023 - 4/16/2024 (Concurrent with Board of Supervisors)~~

Motion carried unanimously. (Verbal vote)

5. Adopt the minutes. MOTION (Scanlon/Rego) to adopt the minutes from the previous meeting.

Motion carried unanimously.

6. General Consent Agenda Items.

a. Human Services Committee:

- i. **Resolution 86 - 2023** To Commend Jan Schyvnick For Over 35 Years Of Service To The People Of Sauk County.

b. Highway Committee:

- i. **Resolution 87 - 2023** To Honor Charles Schell For Over 25 Years Of Faithful Service To The People Of Sauk County.

MOTION (Klitzke/R. Spencer). Motion carried **unanimously.** *(Voice vote)*

7. Scheduled Appearances. None.

8. Public Comment. None.

9. Communications.

Letter from USDA Re: Environmental Assessment & Public Meeting - 11.28.23

10. Appointments.

a. Property Committee:

James Astle, District #18 Supervisor

Term: 11/14/2023-4/16/2024 (Concurrent with Board of Supervisors)

c. Land, Resources, & Environment Director:

Lisa Wilson

MOTION (Schell/Gruber) to approve the appointments. Motion carried **unanimously.** *(Voice vote)*

11. Bills. None.

12. Claims. None.

13. Elections. None.

14. Proclamations. None.

15. Reports – Informational, no action required.

a. Rebecca C. Evert, Sauk County Clerk – Rezoning petitions filed with the office of the Sauk County Clerk as a requirement of Wisconsin State Statutes 59.69(5)(e):

i. Petition 13-2023, **Applicant:** Jay's Holdings LLC; **Project Location:** Town of La Valle; **Current Zoning:** Agriculture; **Proposed Zoning:** Commercial.

ii. Petition 14-2023, **Applicant:** Clayton Yoder; **Project Location:** Town of Westfield; **Current Zoning:** Exclusive Agriculture; **Proposed Zoning:** Agriculture.

iii. Petition 15-2023, **Applicant:** John Wells; **Project Location:** Baraboo; **Current Zoning:** Commercial; **Proposed Zoning:** Resource Conservancy.

b. Brent Miller

i. Administrator's report.

ii. Third Quarter Financial Report. (Report given by Lynn Horkan, Finance Director)

c. Tim McCumber, County Board Chair

i. Board Chair Update

ii. Election paperwork.

iii. Update from Committee on Consolidation of Committees - October Meeting.

16. Unfinished Business.

17. New Business.

LAND RESOURCES & ENVIRONMENT COMMITTEE:

Ordinance 8 - 2023 Amendment To Approve A Map Amendment (Rezoning) Of Lands In The Town Of Freedom From An Agriculture To A Recreation-Commercial Zoning District Filed Upon Mid-Continent Railway Historical Society, Inc., Property Owner.

MOTION (Krueger/Polivka). VOTE: AYES: (31) Roxen, T. Spencer, Eberl, Rego, Kinsman, Klitzke, Scanlon, Anderson, Krueger, Flint, Clemens, Prosser, Lombard, Schell, Dorner, Fordham, Astle, Hazard, R. Spencer, Carver, Polivka, Burchill, Peper, Lohr, Gruber, Detter, Chrisler, Stehling, McAuliffe, Deitrich and McCumber. NAYS: (0). Motion carried unanimously.

Ordinance effective upon passage pursuant to 59.69(5)(e)(6), of Wisconsin State Statutes (November 14, 2023).

PERSONNEL & INSURANCE COMMITTEE

Resolution 88 - 2023 Create New Positions For The 2024 Budget.

MOTION (Gruber/T. Spencer). VOTE: AYES: (31) Roxen, T. Spencer, Eberl, Rego, Kinsman, Klitzke, Scanlon, Anderson, Krueger, Flint, Clemens, Prosser, Lombard, Schell, Dorner, Fordham, Astle, Hazard, R. Spencer, Carver, Polivka, Burchill, Peper, Lohr, Gruber, Detter, Chrisler, Stehling, McAuliffe, Deitrich and McCumber. NAYS: (0). Motion carried unanimously.

FINANCE COMMITTEE:

Resolution 89 - 2023 Approving The 2024 Budget And Establishing Taxes To Be Levied In Sauk County For The Year 2023 (Payable In 2024).

MOTION (Krueger/Polivka).

MOTION (Hazard/Polivka).

To amend the 2024 Proposed Budget, as recommended by the Finance Committee, to fund a needs assessment of health care needs in Sauk County. The funding would balance the 2024 budget by use of the General Fund balance by \$50,000.

VOTE: AYES: (17) T. Spencer, Eberl, Rego, Klitzke, Scanlon, Deitrich, Krueger, Flint, Lombard, Dorner, Fordham, Hazard, R. Spencer, Polivka, Burchill, Stehling, McAuliffe. NAYS: (14) Roxen, Kinsman, Anderson, Clemens, Prosser, Schell, Astle, McCumber, Carver, Peper, Lohr, Gruber, Detter, Chrisler. Motion carried.

MOTION (McCumber/Lohr).

To amend the 2024 Proposed Budget, as recommended by the Finance Committee, to fund landscaping materials and/or services for the UW-Baraboo Campus. The funding would balance the 2024 budget by increasing the estimated sales tax amount by \$20,000.

VOTE: AYES: (30) Roxen, T. Spencer, Eberl, Rego, Kinsman, Klitzke, Scanlon, Anderson, Krueger, Flint, Clemens, Prosser, Lombard, Schell, Dorner, Fordham, Astle, Hazard, R. Spencer, Carver, Burchill, Peper, Lohr, Gruber, Detter, Chrisler, Stehling, McAuliffe, Deitrich and McCumber. NAYS: (1) Polivka. Motion carried.

MOTION (McCumber/Detter).

To amend the 2024 Proposed Budget, as recommended by the Finance Committee, to fund expanding the Senior Healthcare Continuum to provide Assisted Living Facilities on the Reedsburg Campus, to market the Sauk County Health Care Center, and construction of a new Assisted Living facility.

Board Members questioned Corporation Counsel, Brian Desmond, as to whether this proposal is a true budget amendment.

Chair McCumber called a break at 8:17 PM, meeting resumed at 8:27 PM

Corporation Counsel, Brian Desmond, ruled the proposed amendment out of order, as he opined, it is a stringing amendment. McCumber withdrew his motion.

MOTION (Krueger/Polivka) to adopt Resolution 89 - 2023, as amended, Approving The 2024 Budget And Establishing Taxes To Be Levied In Sauk County For The Year 2023 (Payable In 2024).

- Levy rate, including special purpose levies, of \$3.41 per \$1,000.00 (\$0.35 decrease).
- Total levy dollars raised of \$35,124,280.00.

VOTE: AYES: (30) Roxen, T. Spencer, Eberl, Rego, Kinsman, Klitzke, Scanlon, Anderson, Krueger, Flint, Clemens, Prosser, Lombard, Schell, Dorner, Fordham, Astle, Hazard, R. Spencer, Carver, Polivka, Burchill, Lohr, Gruber, Detter, Chrisler, Stehling, McAuliffe, Deitrich and McCumber. NAYS: (1) Peper.
Motion carried.

18. Referrals.

19. New Agenda Items (no discussion). Submit in writing or by e-mail new business items to the County Administrator as soon as possible for Rule III.A. referral.

20. Adjournment to a date certain: 8:36 PM MOTION (Rego/Klitzke) to adjourn until Tuesday, December 19, 2023, at 6:00 P.M. Motion carried unanimously.

Respectfully submitted,



Cora McDonnell
Deputy County Clerk

Minutes Approved: December 19, 2023

State of Wisconsin, County of Sauk: I certify that the above is a true and correct copy of the November 14, 2023. Proceedings of the Sauk County Board of Supervisors. /s/Rebecca C. Evert, Sauk County Clerk.

Original documents on file @ Office of the Sauk County Clerk West Square Building, 505 Broadway, Room #144, Baraboo, WI 53913. 608-355-3286.

www.co.sauk.wi.us

These notices may also be found at: <http://www.wisconsinpublicnotices.org/> or <https://www.co.sauk.wi.us/legalnotices>.

RESOLUTION # 86 -2023

Resolution to Commend Jan Schyvinck for Over 35 Years of Service to the People of Sauk County

Resolution offered by the Human Services Committee

Resolved by the Board of Supervisors of Sauk County, Wisconsin:

BACKGROUND: It is customary for the Sauk County Board of Supervisors to recognize employees who have served the people of Sauk County with distinction. Jan Schyvinck started working for Tri-County Human Services in May of 1978 where she handled Inpatient records and then moved to data reporting and tracking for the Intoxicated Driver Program. She continued through the merge with Sauk County Social Services in 1988. Jan reliably served this great county for the past 45 years (includes 10 years with Tri-County) in a variety of roles. Her job titles have included: Clerk/Typist, Data Systems Operator and most recently, Data Systems Technician. Jan was a person everyone went to due to her vast knowledge of the services and programs Human Services provides. A person with that many years of service leaves a vast hole in a department which is hard to replace.

THEREFORE, BE IT RESOLVED, that the Sauk County Board of Supervisors hereby expresses its sincere appreciation and admiration for Jan Schyvinck and her over 35 years of faithful service to the people of Sauk County.

BE IT FURTHER RESOLVED, that the Chairperson of the Sauk County Board of Supervisors is hereby directed to present Jan with an appropriate symbol of our appreciation for her services.

Approved for presentation to the County Board by the Human Services Committee, this 14th day of November, 2023.

Consent Agenda Item: [X] YES [] NO

Fiscal Impact: [X] None [] Budgeted Expenditure [] Not Budgeted

Vote Required: Majority = _____ 2/3 Majority = _____ 3/4 Majority = _____

The County Board has the legal authority to adopt: Yes _____ No _____ as reviewed by the Corporation Counsel, _____ Date: _____.

Offered and passage moved by:

Patricia Rego, Supervisor Aye Nay Abstain Absent

Delmar Scanlon, Supervisor Aye Nay Abstain Absent

Joel Chrisler, Supervisor Aye Nay Abstain Absent

53
54
55
56
57
58
59
60
61
62
63
64
65
66
67
68
69
70
71

Jake Roxen, Supervisor

Aye Nay Abstain Absent

Joan Fordham, Supervisor

Aye Nay Abstain Absent

Valerie McAuliffe, Supervisor

Aye Nay Abstain Absent

Cliff Thompson, Citizen Member

Aye Nay Abstain Absent

James Bowers, Citizen Member

Aye Nay Abstain Absent

Fiscal Note: No fiscal impact. *JWH*

MIS Note: No information systems impact.

RESOLUTION # 81-2023

Resolution to Honor Charles Schell for over 25 years of Faithful Service to the People of Sauk County

Resolution offered by the Highway Committee
Resolved by the Board of Supervisors of Sauk County, Wisconsin:

BACKGROUND: It is custom of the Sauk County Board of Supervisors to recognize staff members who have served the people of Sauk County with distinction. Charles Schell faithfully served the people of Sauk County by providing over 25 years of service for the Highway Department. Charles started on April 1, 1998 as a Patrolman's Helper. Charles became a Skilled Laborer on October 1, 2000, Skilled Operator on June 21, 2004, Patrolman on March 17, 2014 and currently a Highway Operator 1 starting on 1/1/2021. Charles maintained professional and ethical integrity while serving the County. Charles was an essential team member to the Highway Department and all of Sauk County.

THEREFORE, BE IT RESOLVED, that the Sauk County Board of Supervisors, met in regular session, hereby expresses its appreciation, and commends Charles Schell for over 25 years of faithful service to the people of Sauk County; and

BE IT FURTHER RESOLVED, that the Chairperson of the Sauk County Board of Supervisors is hereby directed to present Charles Schell an appropriate certificate and commendation as a token of our esteem.

Approved for presentation to the County Board by the Highway Committee, this 14th day of November 2023.

Consent Agenda Item: [X] YES [] NO

Fiscal Impact: [X] None [] Budgeted Expenditure [] Not Budgeted

Vote Required: Majority = _____ 2/3 Majority = _____ 3/4 Majority = _____

The County Board has the legal authority to adopt: Yes _____ No _____ as reviewed by the Corporation Counsel, _____, Date: _____

Offered and passage moved by:





	<input checked="" type="checkbox"/> Aye	<input type="checkbox"/> Nay	<input type="checkbox"/> Abstain	<input type="checkbox"/> Absent
Brian Peper				
	<input checked="" type="checkbox"/> Aye	<input type="checkbox"/> Nay	<input type="checkbox"/> Abstain	<input type="checkbox"/> Absent
Terry Spencer				
	<input checked="" type="checkbox"/> Aye	<input type="checkbox"/> Nay	<input type="checkbox"/> Abstain	<input type="checkbox"/> Absent
Smooth Dettler				
	<input checked="" type="checkbox"/> Aye	<input type="checkbox"/> Nay	<input type="checkbox"/> Abstain	<input type="checkbox"/> Absent
Mike Flint				
	<input type="checkbox"/> Aye	<input type="checkbox"/> Nay	<input type="checkbox"/> Abstain	<input type="checkbox"/> Absent
Kevin Schell				

EXHIBIT C



**Land Resources & Environment
Department**
 505 Broadway, Ste. 248
 Baraboo, Wisconsin 53913
 Phone: (608) 355-3245
 Fax: (608) 355-3292
 www.co.sauk.wi.us

Application Accepted:	10-6-23
Accepted By:	Will C
Petition Number:	13-2023
Current Zoning:	Agriculture
Proposed Zoning:	Commercial
Committee Hearing Date:	11-28-23
County Board Date:	12-19-23
Supervisor District #:	4

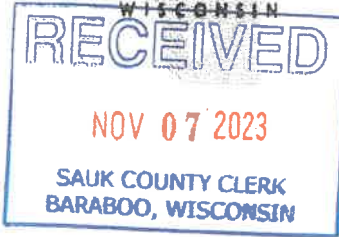
Zoning Map Amendment (Rezone) Application

General Information

OCT 09 2023

Property Owner Name: Jay's Holdings	Home Phone: 608-768-3297
Mailing Address: 1515 East Main Street Reedsburg, WI 53959	Cell Phone: 608-393-4807
E-mail Address: jay@jayspowercenter.com	
Agent/Applicant Name: Doug Mittelstaedt	Home Phone: 608-393-4807
Mailing Address: 1151 Pineview Drive Reedsburg, WI 53959	Cell Phone: 608-415-0331
E-mail Address: dmittelstaedt@ramchealth.org	

Site Information

Site Address: E3350 Minicreek Road
Parcel ID: 0569-1000
Property Description: SW ¼ SW ¼ Section 21, T 13 N, R 3 E,
Town of: LaValle
Overlay District: <input type="checkbox"/> Shoreland <input type="checkbox"/> Floodplain <input type="checkbox"/> Airport
Current Use: Land is used for agriculture and buildings are used for storage
Current Zoning: Agriculture/ Commercial

Existing Structures/Improvements: 2 Pole Buildings use for storage

Proposed Zoning

Proposed Ordinance Section	Proposed Zoning/Use Description
7.150	Commercial

Describe specifically the nature of the request (be sure to list all proposed uses of the property). What do you plan to do? Please attach additional sheets, if necessary.

We would like to add 5 60X120 storage buildings to the property. These buildings would be used by Mittelstaedt Sports and Marine and Jay's Power Center to store customers items in(boats,atv's, utv's, campers, etc.).

ck# 3150 #250
 Rec # 010608

General Application Requirements

Applications will not be accepted until the applicant has met with department staff to review the application and determine if all the necessary information has been provided. All information from the checklist must be provided to the Department to be considered a complete application. Only complete applications submitted by the deadline will be noticed for a specific hearing date/time.

- Completed Zoning Map Amendment Application Form.
- \$500 application fee (non-refundable), payable to Sauk County LRE.
- Town/County Scheduling Form completed by the applicant and Township.
- A scaled map of the proposed rezone area (if the property is not vacant the location of buildings, driveways, etc. must be shown).
- Legal description of the area to be rezoned (CSM, Metes & Bounds description)
- Any other information as required by the zoning administrator to explain the request.

Zoning Map Amendment Standards

Explain how the proposed rezone is consistent with the overall purpose and intent of the zoning ordinance.

The front portion of the property is currently zoned commercial and we would like to zone the remainder of the property to commercial as well.

If rezoning out of an Exclusive Agriculture Zoning District explain how the land is better suited for a use not allowed in the Exclusive Agriculture Zoning District and how the rezoning will not substantially impair or limit future agricultural use of surrounding parcels of land that are zoned for or legally restricted to agricultural use.

The area that we we would like to change to commercial has sandy soil and is hard to use for agricultural.

The front part of the property is already zoned as commercial and is being used for storage so we thought it would make sense to keep the areas together rather than have storage areas all around.

Certification

I certify by my signature that all information presented herein is true and correct to the best of my knowledge. I give permission for the staff of the Sauk County Land Resources & Environment Department to enter my property for the purpose of collecting information to be used as part of the public hearing process. I understand that the rezone fee is a non-refundable, regardless if the rezone is approved or denied. I understand that the fee for this application is only for the rezone request and if permits are required for the project that those will require separate application(s) and/or fee(s). I understand that partial or incomplete applications will be returned to the applicant resulting in the application being removed from the hearing agenda and the submittal deadlines will restart. I further agree to withdraw this application if substantive false or incorrect information has been included.

Applicant/Agent: Doug Mittelstaedt Date: 7/14/2023

Property Owner Signature: Jay Mittelstaedt 289 Date: 7/14/2023

Zoning Map Amendment Procedures and Requirements

At the public hearing, the applicant may appear in person or through an agent or an attorney of their choice. The applicant/agent/attorney may present testimony, evidence and arguments in support of the application. All site plans, pictures, etc. become the property of the Land Resources & Environment Department, will remain in the file, and will be public record.

What is a Zoning Map Amendment?

The purpose of a zoning map amendment is to alter, enlarge, or reduce a geographic extent of any zoning district, or to enact a new zoning designation for any particular parcel or real property. A change in zoning allows for different land uses and in some instances, different densities of development. The Land Resources & Environment Committee will recommend approval or disapproval of a rezone to the Sauk County Board of Supervisors in accordance with the standards and criteria set by the zoning ordinance.

Standards and Criteria

In reviewing a Zoning Map Amendment request, the LRE Committee must follow four standards:

- a) The proposed map amendment is consistent with the overall purpose and intent of the zoning ordinance.
- b) The proposed map amendment is consistent with the Sauk County Comprehensive Plan and the Farmland Preservation Plan, if applicable.
- c) Factors have changed from the time of initial ordinance adoption that warrant the map change, or an error, inconsistency, or technical problem administering the zoning ordinance as currently depicted has been observed.
- d) In rezoning land out of any exclusive agriculture district, the agency shall find all of the following, after a public hearing:
 1. The land is better suited for a use not allowed in the exclusive agriculture district.
 2. The rezoning is consistent with the Sauk County Comprehensive Plan.
 3. The rezoning is substantially consistent with the Sauk County Farmland Preservation Plan.
 4. The rezoning will not substantially impair or limit current or future agricultural use of surrounding parcels of land that are zoned for or legally restricted to agricultural use.

Note: Pursuant to Wis. Stat § 91.48(1) A political subdivision (Sauk County) with a certified farmland preservation zoning ordinance may not rezone land out of a farmland preservation zoning district (Exclusive Agriculture) without having the rezoning certified under Wis. Stat § 91.36 and provided that the standards (a) through (d) above are met.

Process

1. Contact the LRE Department to schedule a meeting to review your potential request.
2. Complete the Zoning Map Amendment Application and provide all the supplemental items to the LRE Department by the filing deadline.
3. Review such application with the appropriate staff member to determine completeness.
4. If the application is complete, LRE staff will publish notice of your request for a zoning map amendment in the County's official newspaper noting the location and time of the required public hearing before the LRE Committee. Neighbors, town officials, and affected state agencies will be notified as well.
5. If the Town chooses to review the zoning map amendment request at the Town Planning Commission and Town Board level, you will need to attend such meetings to provide information regarding the request. Please request that copies of minutes/proceedings outlining the Town's recommendation be provided to the LRE Department for the file.
6. A public hearing will be held before the LRE Committee. Either the property owner or designated agent will need to be present at the hearing to provide testimony regarding the request. The LRE Committee must make a decision based only on the evidence that is submitted to it at the time of the hearing. Failure to provide representation may result in denial or postponement of your request.
7. The LRE Committee and Sauk County Board of Supervisors may approve, disapprove, or modify and approve the zoning map amendment request.

Please Note: If a zoning map amendment application is dis approved by the LRE Committee and no appeal is filed, no new zoning map amendment application can be re-submitted for a period of 365 days from the date of the LRE Committee's decision, except on grounds of new evidence or proof of changes of factors found valid by the LRE Committee.

PLAT OF SURVEY

A PARCEL OF LAND LOCATED IN THE NW1/4-SW1/4 AND THE SW1/4-SW1/4 OF SECTION 21, T13N, R9E, TOWN OF LA VALLE, SAUK COUNTY, WISCONSIN.



BEARINGS ARE REFERENCED TO THE SOUTH LINE OF THE SW1/4 OF SECTION 21, ASSURED TO BEAR S89°23'05"E.

CLIENT'S:
BRIAN & JULIE RABUCK
E3396 MINICREEK ROAD
LAVALLE, WI 53941

UNPLATED LANDS OWNED BY CLIENT'S

LEGEND:

- ⊙ HARRISON CAST IRON MONUMENT F.I.D.
- 3/4" X 18" REBAR SET WEIGHING 1.50 LBS./LIN. FT.
- ▲ P.K. NAIL SET
- 3/4" REBAR FOUND
- △ COMPUTED POSITION

PARCEL 'A'
7.50 ACRES
326,513 SQ. FT.

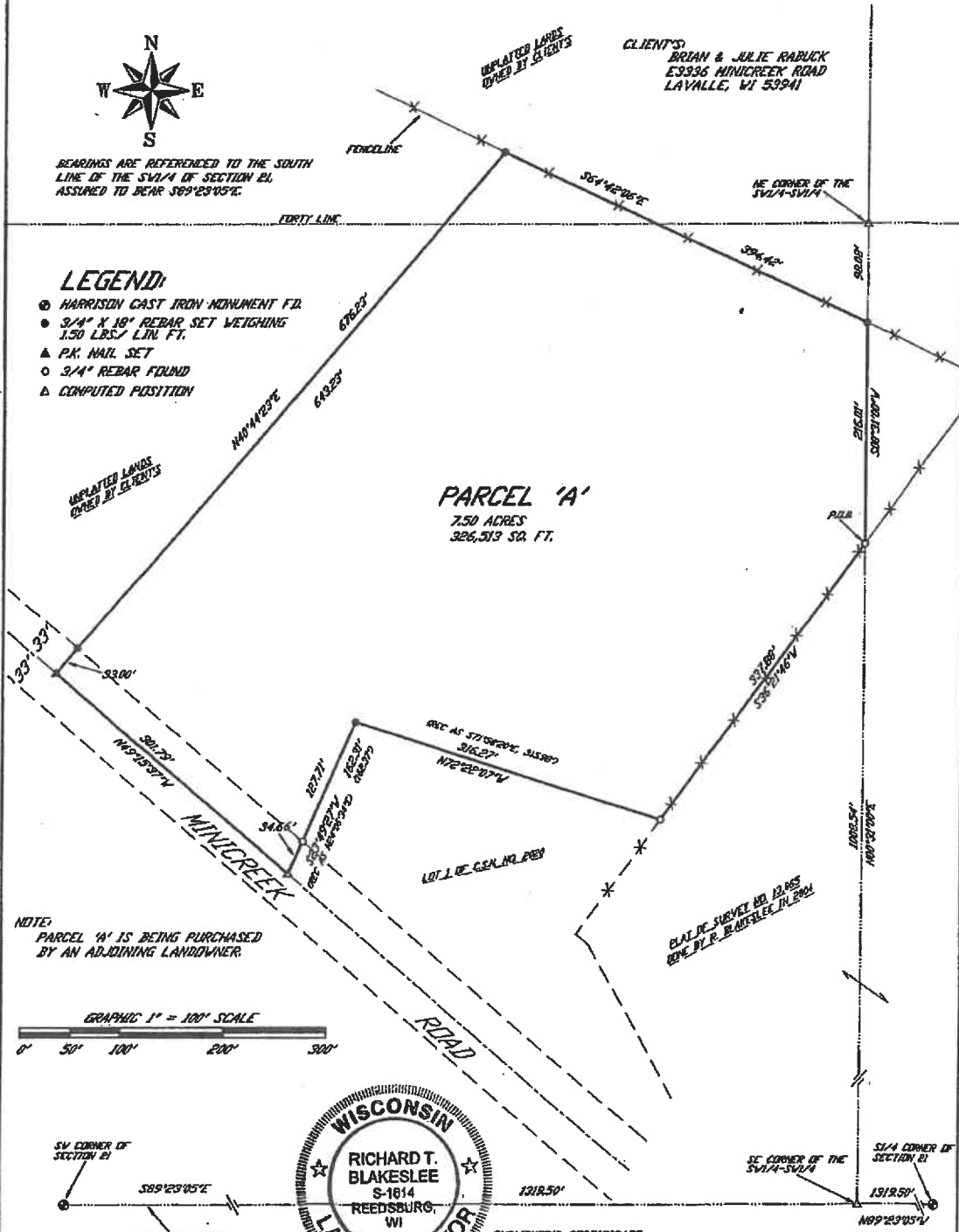

NOTE:
PARCEL 'A' IS BEING PURCHASED BY AN ADJOINING LANDOWNER.

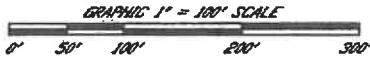

SURVEYOR'S CERTIFICATE

I, RICHARD T. BLAKESLEE, REGISTERED LAND SURVEYOR, HEREBY CERTIFY THAT I HAVE SURVEYED, COMPILED AND MAPPED A PARCEL OF LAND LOCATED IN THE TOWN OF LA VALLE, AND THAT THE ABOVE PLAT IS A TRUE AND CORRECT REPRESENTATION OF THE LANDS SURVEYED TO THE BEST OF MY KNOWLEDGE AND BELIEF.

Richard T. Blakeslee
 RICHARD T. BLAKESLEE
 REGISTERED LAND SURVEYOR S-1614

BLAKESLEE LAND SURVEYING
1228 EAST MAIN STREET
REEDSBURG, WI 53969
(608) 824-0402
AUGUST 21, 2009
DRAFTED BY J. MURPHY / CHECKED BY R. BLAKESLEE

291 08-21-2009 DATE

Legal Description of Parcel 'A'

A parcel of land located in the NW1/4-SW1/4 and the SW1/4-SW1/4 of Section 21, T13N, R3E, Town of La Valle, Sauk County, Wisconsin; being more fully described as follows:

Commencing at the South ¼ corner of Section 21; thence N89°23'05"W, 1319.50 feet along the South line of the Southwest ¼ of Section 21 to the Southeast corner of the SW1/4-SW1/4 of Section 21; thence N00°31'00"E, 1008.54 feet along the East line of the aforesaid forty to the point of beginning; thence S36°21'46"W, 337.88 feet to the Northeast corner of Lot 1 of Certified Survey Map Number 2020; thence N72°22'07"W, 316.27 feet along the Northerly line of said Lot 1 to the Northwest corner thereof; thence S23°49'27"W, 162.31 feet along the Westerly line of said Lot 1 to the Southwest corner thereof, said point being located on the centerline of Minicreek Road; thence N49°15'37"W, 301.79 feet along said centerline; thence N40°44'23"E, 676.23 feet; thence S64°42'06"E, 394.42 feet to a point on the East line of the SW1/4-SW1/4 of Section 21; thence S00°31'00"W, 216.01 feet along the aforesaid East line to the point of beginning.

Said parcel contains 7.50 acres, more or less, and is subject to the rights-of-way of Minicreek Road and all utility easements of record.

PROJECT NO. #9465

M.S.A. FILE NO. 38-12-179

CLIENT: TOWNE & COUNTRY NURSERY
STREET: E 3350 MINI CREEK ROAD
CITY: LAVALLE, WISCONSIN 53941

SCALE 1"=100'
SHEET 1 OF 1
SIDE 1 OF 2

MID-STATE ASSOCIATES INC. BARABOO, WISCONSIN 53913

SAUK COUNTY CERTIFIED SURVEY MAP NO. 2020

LOCATED IN THE SW1/4-SW1/4, SECTION, 21, T13N, R3E,
TOWN OF LAVALLE, SAUK COUNTY, WISCONSIN

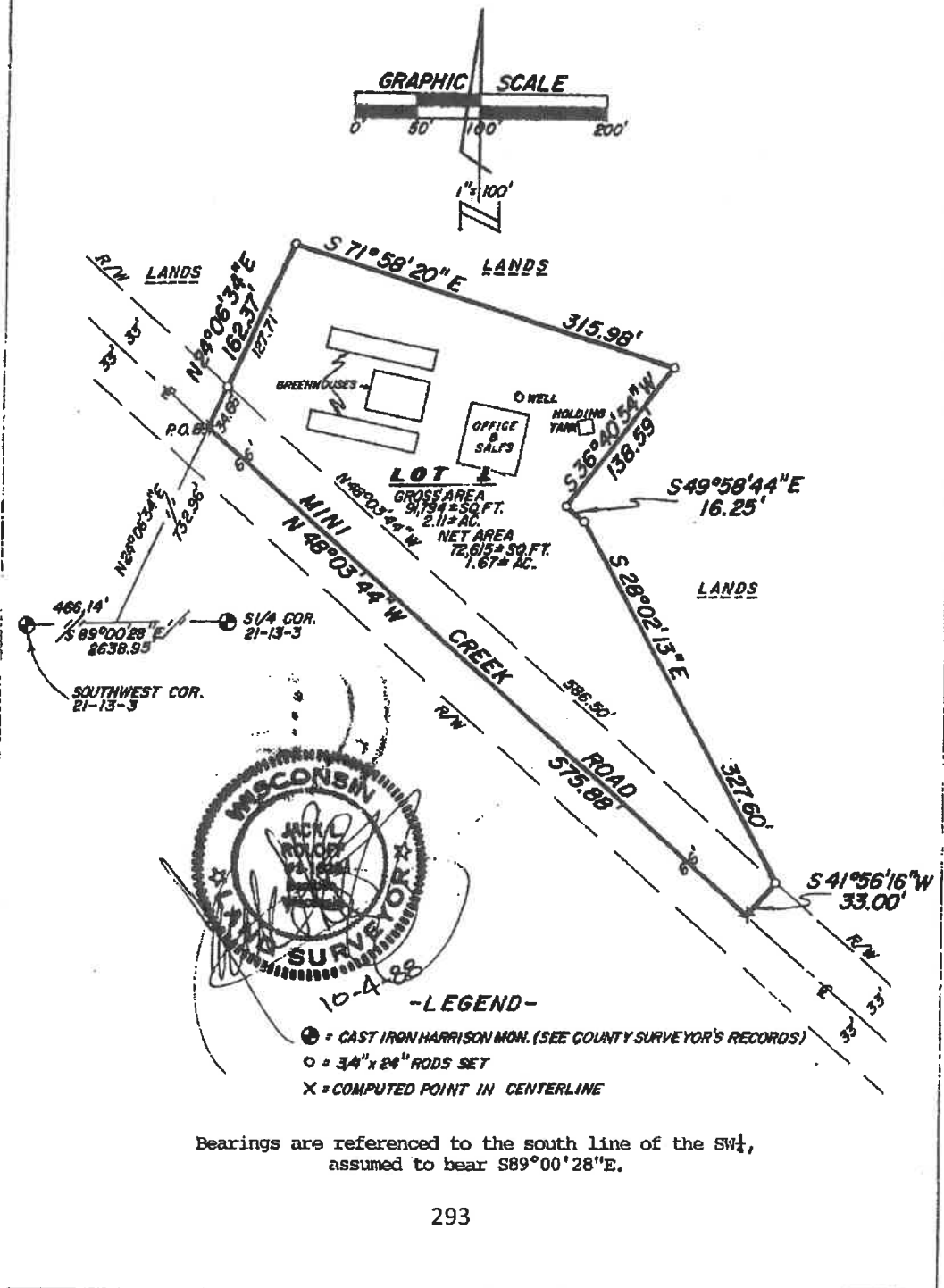

11/19/20

SURVEYOR'S CERTIFICATE

I, Jack L. Roloff, Registered Land Surveyor hereby certify that I have surveyed, divided and mapped a certified survey located in the SW $\frac{1}{4}$ -SW $\frac{1}{4}$, Section 21, T13N, R3E, Town of LaValle, Sauk County, Wisconsin, described as follows:

Commencing at the southwest corner of Section 21, T13N, R3E; thence S89°00'28"E, 466.14 feet along the south line of the SW $\frac{1}{4}$ Section 21, T13N, R3E; thence N24°06'34"E, 732.96 feet to the point of beginning;

thence continuing N24°06'34"E, 162.37 feet; thence S71°58'20"E, 315.98 feet; thence S36°40'54"W, 138.59 feet; thence S49°58'44"E, 16.25 feet; thence S28°02'13"E, 327.60 feet; thence S41°56'16"W, 33.00 feet; thence N48°03'44"W, 575.88 feet to the beginning.

Said parcel contains 2.11 acres more or less, and is subject to all easements and rights-of-way of record.

That I have complied with the provisions of Chapter 236.34 Wisconsin Statutes, the subdivision regulations of Sauk County and A.E. 7 of the Administrative Code of the State of Wisconsin to the best of my knowledge and belief, in surveying, dividing and mapping the same;

That such plat is a correct representation of all the exterior boundaries of the land surveyed and the subdivision thereof made;

That I have made such certified survey under the direction of TOWNE & COUNTRY NURSERY.

10-4-88
Date

Jack L. Roloff
Registered Land Surveyor

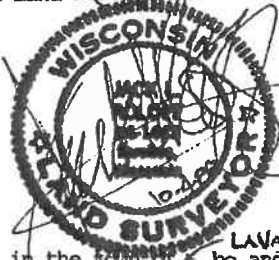

SAUK COUNTY PLANNING AGENCY APPROVAL

Resolved, that this certified survey map in the town of LAVALLE, be and hereby is approved in compliance with Chapter 236 of the Wisconsin State Statutes and the County Planning Agency Subdivision Regulations.

I hereby certify that the foregoing is a true and correct copy of a resolution adopted by the Sauk County Planning Agency and made effective this 17 day of October, 1988.

October 17, 1988
Date

[Signature]
Administrator

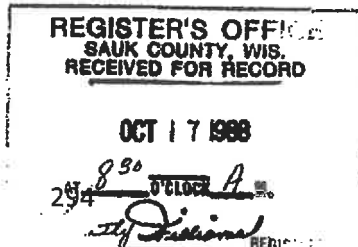

516875

X
X

602



Land Resources & Environment
 Department
 505 Broadway, Ste. 248
 Baraboo, Wisconsin 53913
 Phone: (608) 355-3245
 Fax: (608) 355-3292
 www.co-sauk.wi.us

Application Accepted: 10-6-23
 Accepted By: Will C
 Petition Number: 13-2023
 Hearing Date: 11-26-23
 Supervisor District #: 4

RECEIVED
 SAUK COUNTY

OCT 09 2023

LAND RESOURCES &
 ENVIRONMENT DEPT

Conditional Use Permit Application

General Information

Property Owner Name: Jay's Holdings	Home Phone: 608-768-3297
Mailing Address: 1515 East Main Street Reedsburg, WI 53959	Cell Phone: 608-393-4807
E-mail Address: jay@jayspowercenter.com	
Agent/Applicant Name: Doug Mittelstaedt	Home Phone: 608-393-4807
Mailing Address: 1151 Pineview Drive Reedsburg, WI 53959	Cell Phone: 608-415-0331
E-mail Address: dmittelstaedt@ramchealth.org	

Site Information

Site Address: E3350 Minicreek Rd.
 Parcel ID: 0569-1000
 Property Description: SW ¼ SW ¼ Section 21, T 13N, R 3 E,
 Town of: LaValle Zoning: Agriculture/
 Overlay District: Shoreland Floodplain Airport Commercial
 Current Use: Land is used for agriculture and buildings are used for storage
 Existing Structures/Improvements: 2 Pole Buildings use for storage

Proposed Use

Applicable Ordinance Section	Description
7.040	warehousing

Describe specifically the nature of the request (be sure to list all proposed uses of the property). What do you plan to do? Please attach additional sheets, if necessary.

We would like to add up to 5 - 60X120 storage buildings to the property. These buildings would be used by Mittelstaedt Sports and Marine and Jay's Power Center to store customers items in (boats, atv's, utv's, campers, etc.).

295

CR# 3150 \$250

If your proposal has additional development or secondary standards, please explain how your proposal meets or exceeds those requirements. Please attached additional sheets, if necessary.

The front of the property is currently zoned as commercial and has two pole sheds that are being used for storage, we are looking to expand upon the amount of storage that we have on the property. We would like to be able to add up to 5 additional 60X190 sheds to the back side of the existing sheds. We have a growing need for indoor storage in our area and would like to keep our storage close to our shops and lakes for easy access in and out. We have placed the building on the property in a way to make sure that we stay out of any flood plans and have put in run-off area and retention pond to accommodate the run off water. This area will have varying access, fall and spring when boats are coming out of the water and going in we will have a fair amount of traffic the rest of the time will be very minimal. We are planning on adding a fence to keep the area secure.

General Application Requirements

Applications will not be accepted until the applicant has met with department staff to review the application and determine if all the necessary information has been provided. All information from the checklist must be provided to the Department to be considered a complete application. Only complete applications submitted by the deadline will be noticed for a specific hearing date/time.
<input checked="" type="checkbox"/> Completed Conditional Use Permit Application Form.
<input type="checkbox"/> A completed Land Use Permit Application Form with appropriate fee, payable to Sauk County LRE
<input type="checkbox"/> A completed Town/County Scheduling Form
<input type="checkbox"/> \$500 application fee (non-refundable), payable to Sauk County LRE
<input checked="" type="checkbox"/> A written narrative of the proposed conditional use; to include: a description of the proposed business activity; equipment used in the business activity; days/hours of operation; number of employees; noise, dust, vibration, fumes abatement measures; visual screening measures; and other features or characteristics (signs, fences, outdoor display/storage areas, etc.).
<input checked="" type="checkbox"/> A scaled site plan which shall include the location of all existing and proposed buildings, driveways, entrances, sidewalks, trails, and signs; the location, size number and screening of all parking spaces.
<input checked="" type="checkbox"/> Landscaping Plan, if applicable.
<input checked="" type="checkbox"/> Stormwater and Erosion Control Plan, if applicable.
<input type="checkbox"/> A detailed proposal including covenants, agreements, or other documents showing the ownership and method of assuring perpetual maintenance of land to be owned or used for common purposes.
<input checked="" type="checkbox"/> Building elevation and floor plans, if applicable.
<input type="checkbox"/> Any other information as required by the zoning administrator to explain the request.

Conditional Use Standards

Part A: Conditional Use Standards

Please explain how the establishment, maintenance, or operation of the proposed use may not be detrimental to or endanger the public health, safety, or general welfare of the occupants of surrounding lands.

I do not see any health or safety risks around the proposed plans.

Please explain how the use will be designed constructed, operated, and maintained so as to be compatible and be appropriate in appearance with the existing or intended character of the general vicinity, and that such use may not change the essential character of the area by substantially impairing or diminishing the use, value or enjoyment of existing or future permitted uses in the area.

Currently there are two pole sheds at the front of the property and we would be putting the new sheds behind the existing ones. The land is currently being used for farming but the crop yield is low and hard to rent out due to the small size of the property. We will be using building colors to help make the building blend into the surroundings and not stick out.

Part B: Conditional Use Criteria

Please explain how the proposed conditional use is able to address the following:

- (a) Erosion potential of the site based on topography, drainage, slope, soil type, and vegetative cover and mitigation of erosion potential.
- (b) The prevention and control of water pollution, including sedimentation, and the potential impacts on floodplain and wetlands.
- (c) Whether the site has adequate utilities including, acceptable disposal systems.
- (d) Whether the site has access to roads and highways.
- (e) Whether the site has suitable ingress and egress.
- (f) Whether the site is designed to minimize traffic congestion, and the potential effect on traffic flow.

- A) We will be installing a retention area for any water run off to help keep control any erosion
- B) The way we have set up the water flow on the property will make potential for any impacts on the surrounding land to be minimal if any.
- C) The buildings being added will not have any significant impact on utility's. No bathrooms, showers, or sinks the building will have minimal lighting so that you can navigate safely at night.
- D) The current driveway off of Minicreek is going to be used to enter and exit the property.
- E) The site is set up nicely for both ingress and egress
- F) The additional sheds will not have a significant impact on any traffic flow on the road or surrounding areas

Certification

I certify by my signature that all information presented herein is true and correct to the best of my knowledge. I give permission for the staff of the Sauk County Land Resources & Environment Department to enter my property for the purpose of collecting information to be used as part of the public hearing process. I understand that the conditional use fee is a non-refundable, regardless if the conditional use is approved or denied. I understand that the fee for this application is only for the conditional use request and if permits are required for the project that those will require separate application(s) and/or fee(s). I understand that partial or incomplete applications will be returned to the applicant resulting in the application being removed from the hearing agenda and the submittal deadlines will restart. I further agree to withdraw this application if substantive false or incorrect information has been included.

Applicant/Agent: Doug Mittelstaedt Date: 7/14/2023
 Property Owner Signature: Jay Mittelstaedt Date: 7/14/2023

At the public hearing, the applicant may appear in person or through an agent or an attorney of their choice. The applicant/agent/attorney may present testimony, evidence and arguments in support of the application. All site plans, pictures, etc. become the property of the Land Resources & Environment Department, will remain in the file, and will be public record.

Conditional Use Procedures and Requirements

What is a conditional use?

A conditional use is a land use that may be permitted in a respective zoning district only after approval is granted by the Land Resources & Environment Committee (LRE) in accordance with the standards and criteria set by the zoning ordinance. A conditional use is not suited to all locations in a zoning district, but may be allowed in some locations if it is not contradictory to the ordinance's standards/criteria and the general purpose statement for the particular zoning district. The Agency may approve such a request with conditions, which generally relate to the site's suitability and compatibility with neighboring land uses. Conditional uses must be custom tailored to a specific location and must be listed as such in the use table key of the zoning ordinance.

Standards and Criteria

In reviewing a Conditional Use request, the LRE Committee must follow two standards:

- a) The establishment, maintenance, or operation of the proposed use may not be detrimental to or endanger the public health, safety, or general welfare of the occupants of surrounding lands.
- b) The use will be designed constructed, operated, and maintained so as to be compatible and be appropriate in appearance with the existing or intended character of the general vicinity, and that such use may not change the essential character of the area by substantially impairing or diminishing the use, value or enjoyment of existing or future permitted uses in the area.

The LRE Committee must also consider the request based on the following:

- (a) Erosion potential of the site based on topography, drainage, slope, soil type, and vegetative cover and mitigation of erosion potential.
- (b) The prevention and control of water pollution, including sedimentation, and the potential impacts on floodplain and wetlands.
- (c) Whether the site has adequate utilities including, acceptable disposal systems.
- (d) Whether the site has access to roads and highways.
- (e) Whether the site has suitable ingress and egress.
- (f) Whether the site is designed to minimize traffic congestion, and the potential effect on traffic flow.

If the LRE Committee finds that the standards and criteria have been met, the committee has the authority to grant the conditional use permit. The Committee also has the authority to attach conditions and restrictions on the establishment, location, maintenance, and operation of the conditional use as it deems necessary to ensure that the proposed conditional use adheres to the purpose and review criteria within the zoning ordinance.

Process

1. Contact the LRE Department to schedule a meeting to review your potential request.
2. Complete the Conditional Use Permit Application and provide all the supplemental items to the LRE Department by the filing deadline.
3. Review such application with the appropriate staff member to determine completeness.
4. If the application is complete, LRE staff will publish notice of your request for a conditional use in the County's official newspaper noting the location and time of the required public hearing before the LRE Committee. Neighbors, town officials, and affected state agencies will be notified as well.
5. If the Town chooses to review the conditional use request at the Town Planning Commission and Town Board level, you will need to attend such meetings to provide information regarding the request. Please request that copies of minutes/proceedings outlining the Town's recommendation be provided to the LRE Department for the file.
6. A public hearing will be held before the LRE Committee. Either the property owner or designated agent will need to be present at the hearing to provide testimony regarding the request. The LRE Committee must make a decision based only on the evidence that is submitted to it at the time of the hearing. Failure to provide representation may result in denial or postponement of your request.
7. If the LRE Committee grants your conditional use you must obtain a land use permit from the LRE Department. A conditional use must be initiated by securing a land use permit within 365 days of the date of the approval. Failure to do so will result in the conditional use being void. The permit will be issued if all of the requirements of the Department and any conditions of the Committee have been addressed.
If the LRE Committee denies your conditional use, the decision will become final unless a written appeal is filed with the Zoning Administrator within 30-days of the decision. Appeals are heard before the Board of Adjustment.

8. *Please Note: If a conditional use application is denied by the LRE Committee and no appeal is filed, no new conditional use application can be re-submitted for a period of 365 days from the date of the LRE Committee's decision, except on grounds of new evidence or proof of changes of factors found valid by the LRE Committee*

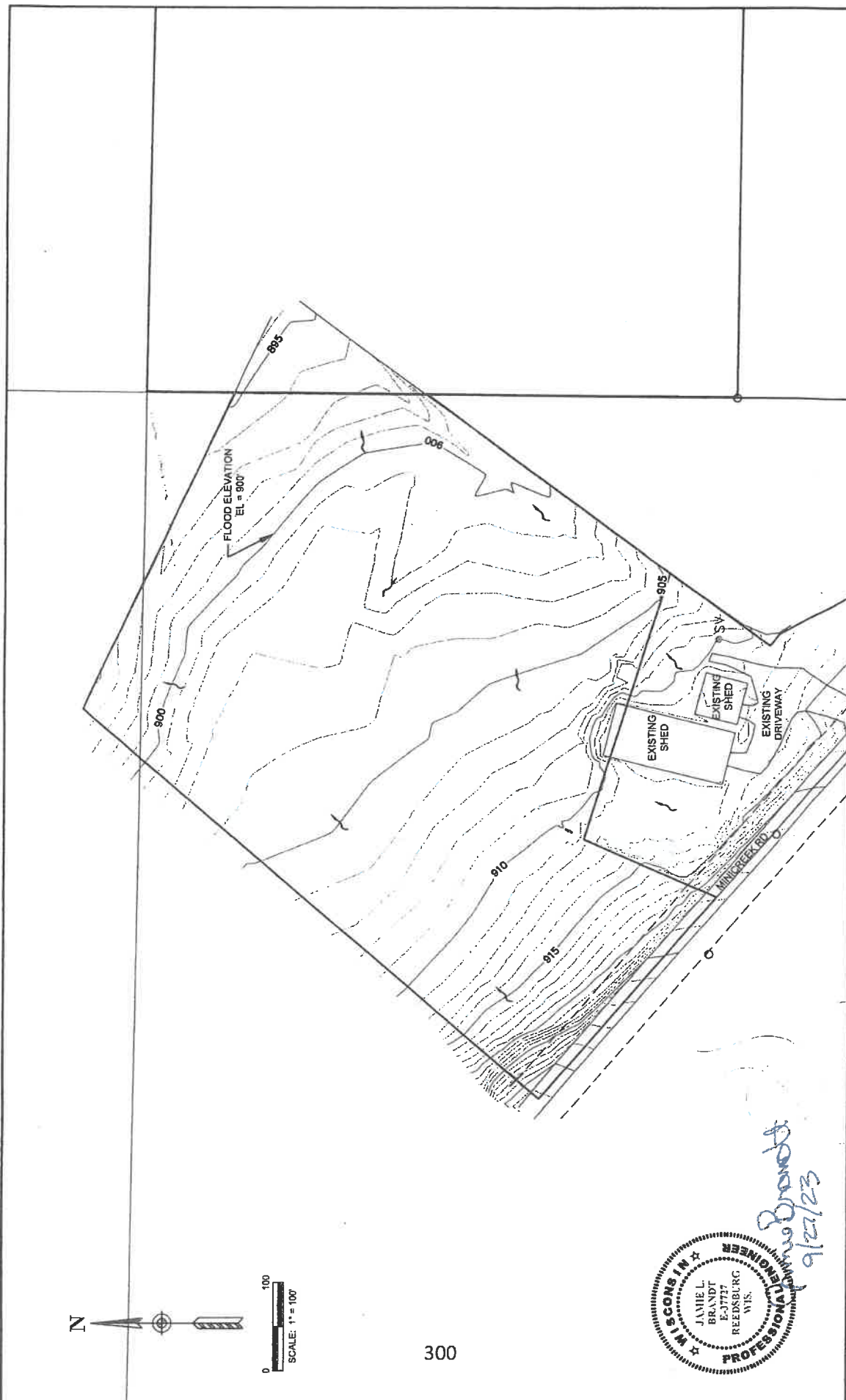

300



REVISION	DATE	REMARKS	JOB NUMBER	DRAFTER	CHECKED	DATE	SHEET NAME	PROJECT	CLIENT	SHEET
			23-2003-1	RTS	JLB	9/27/23	EXISTING	EXISTING	JAY'S HOLDINGS LLC TOWN OF LAVALLE SAUK COUNTY	1 OF 6



Registration: Environmental
Professional Engineer
and Land Surveying

118 E. Maple Street
Reedsburg, WI 53655
Phone: (608) 783-3074

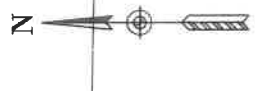
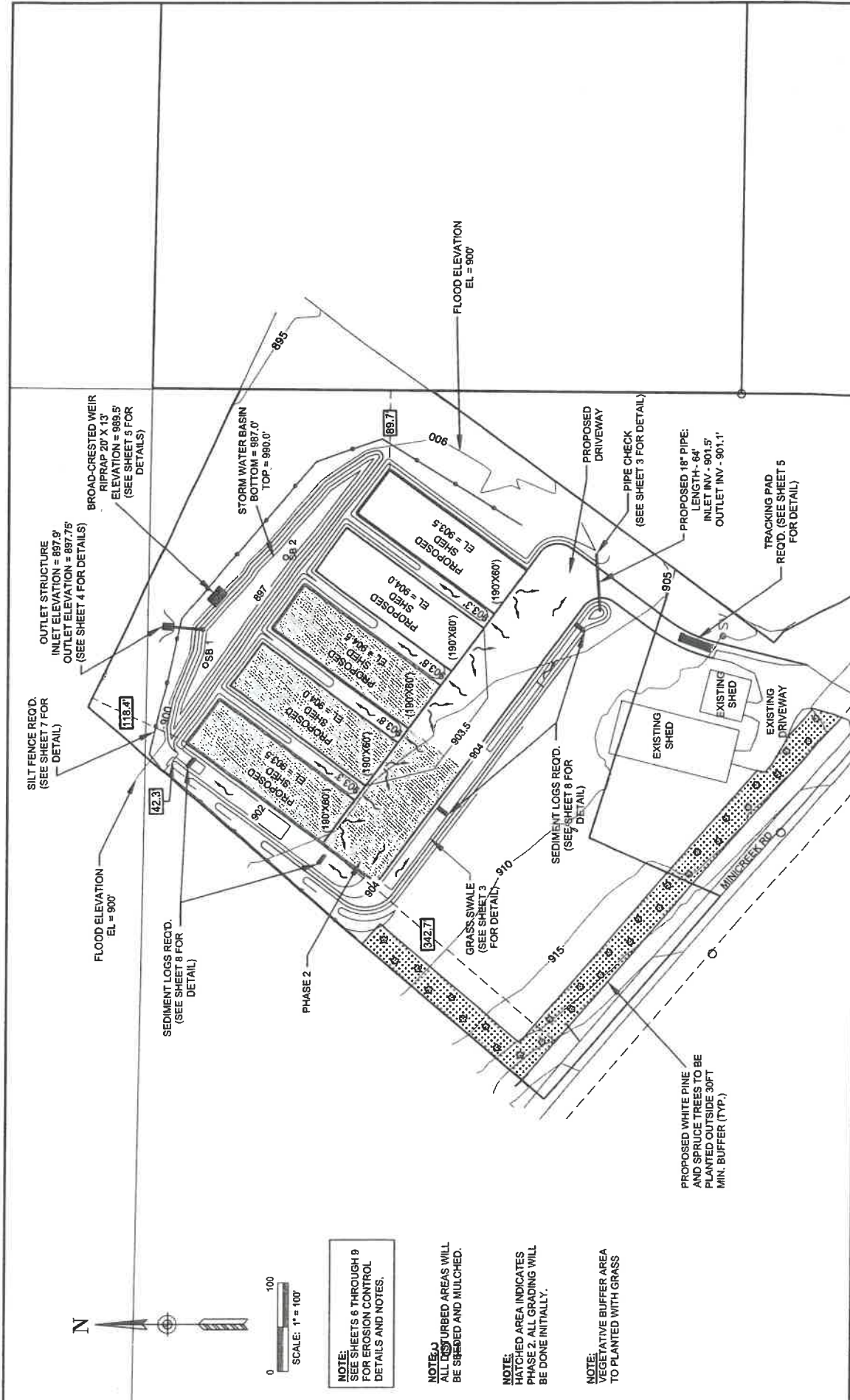

NOTE:
SEE SHEETS 6 THROUGH 9
FOR EROSION CONTROL
DETAILS AND NOTES.

NOTE:
ALL DISTURBED AREAS WILL
BE SEEDED AND MULCHED.

NOTE:
HATCHED AREA INDICATES
PHASE 2. ALL GRADING WILL
BE DONE INITIALLY.

NOTE:
VEGETATIVE BUFFER AREA
TO PLANTED WITH GRASS

REVISION	DATE	REMARKS	JOB NUMBER	DRAFTER	CHECKED	DATE	SHEET NAME
			23-2003-1	RTS	JLB	9/27/23	PROPOSED

118 E. Main Street Readsburg, WI 53099 Phone: (608)768-5074			Transportation : Environmental Agriculture : Municipal and Land Surveying	JAY'S HOLDINGS LLC TOWN OF LAVALLE SAUK COUNTY	SHEET 2 OF 9
			PROPOSED		

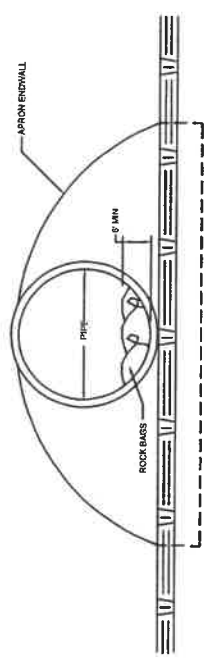

END VIEW

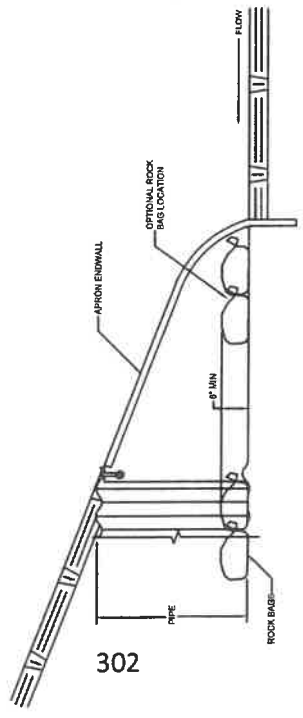

SIDE VIEW

CULVERT PIPE CHECK
(INSTALL ON INLET END ONLY)

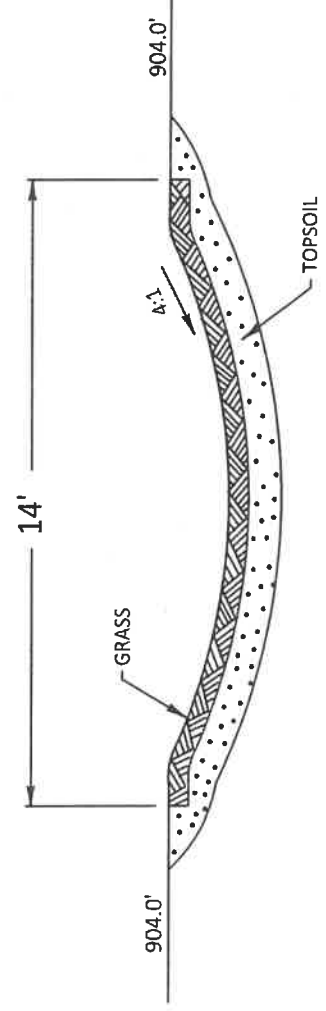

DETAIL OF GRASS SWALE

REVISION	DATE	REMARKS	JOB NUMBER	DRAFTER	CHECKED	DATE	SHEET NAME	SHEET
			23-2003-1	RTS	JLB	9/27/23	STORM DETAIL 1	3 OF 9

118 E. Main Street
Rendburg, WI 53959
Phone: (608)768-3074



Transportation: Environmental
Agricultural: Municipal
and Land Surveying

JAY'S HOLDINGS, LLC
TOWN OF LAVALLE
SAUK COUNTY

STORM DETAIL 1

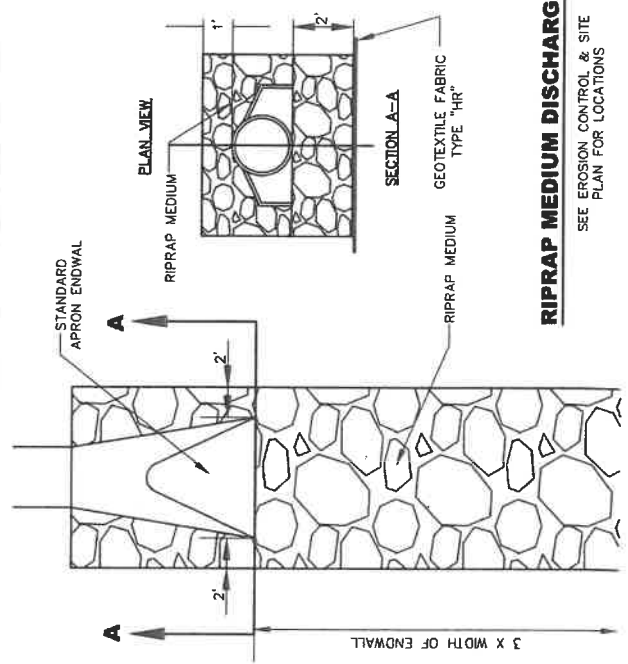
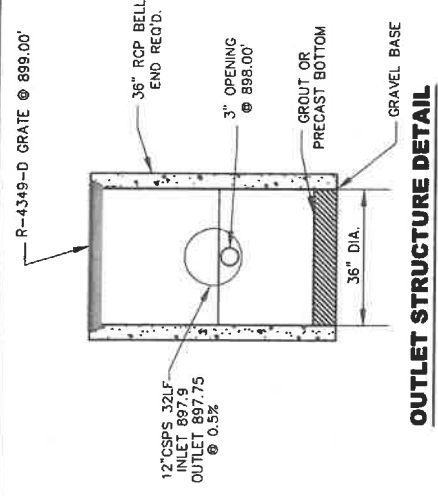
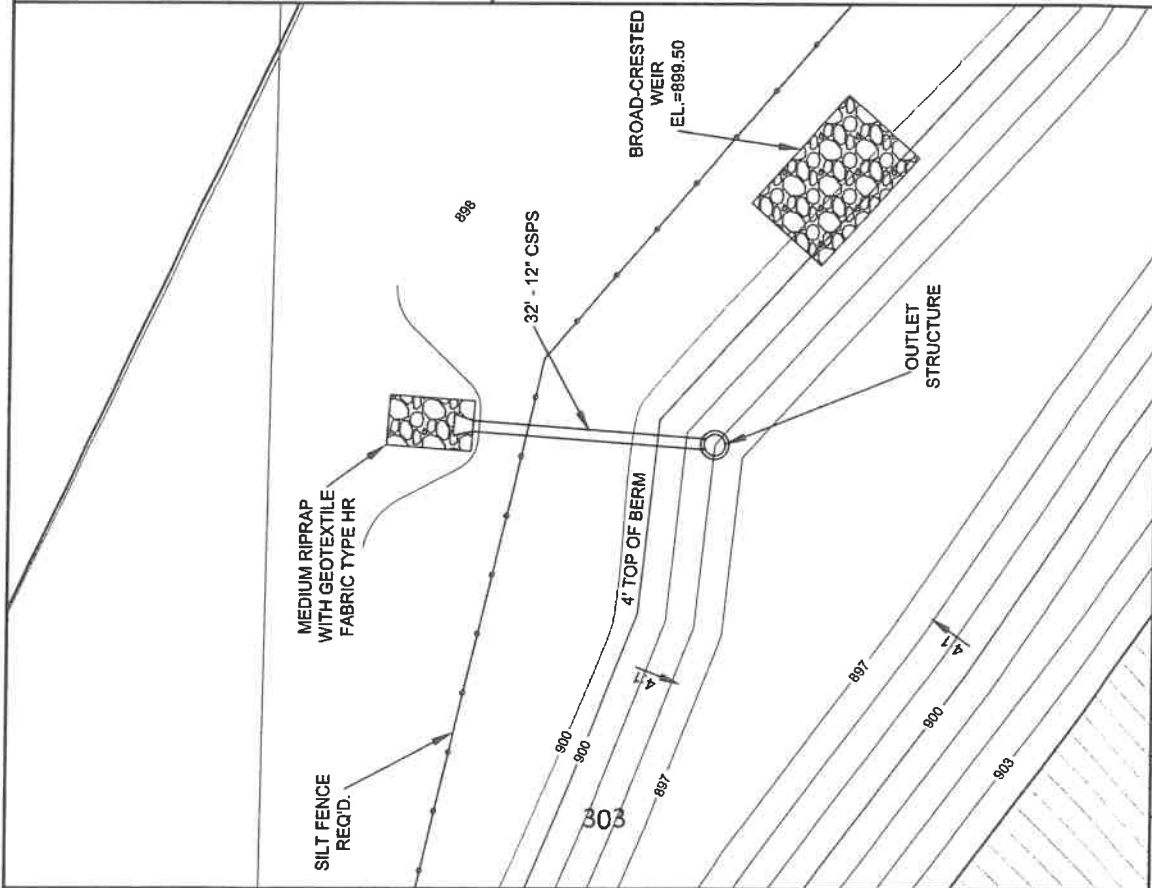

SEE EROSION CONTROL & SITE PLAN FOR LOCATIONS

REVISION	DATE	REMARKS	JOB NUMBER	DRAFTER	CHECKED	DATE	SHEET NAME
			23-2003-1	RTS	JLB	9/27/23	STORM DETAIL 2

118 E. Main Street Reeseburg, WI 53859 Phone: (608)768-5074	TRANSPERATION: Environmental Agricultural, Municipal and Land Surveying	JAY'S HOLDINGS LLC TOWN OF LAVALLE SAUK COUNTY	STORM DETAIL 2	SHEET 4 OF 9
---	---	--	----------------	-----------------



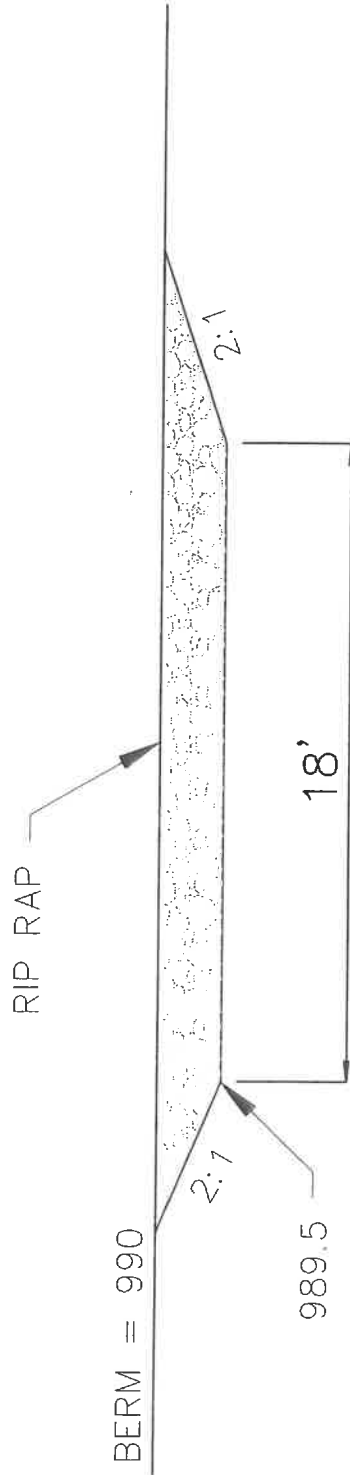

BROAD-CRESTED WEIR DETAIL

304

REVISION	DATE	REMARKS	JOB NUMBER	DRAFTER	CHECKED	DATE	SHEET NAME	SHEET
			23-2003-1	RTS	JLB	9/27/23	STORM DETAIL 3	5 OF 8
			118 E. Main Street Reedburg, WI 53959 Phone: (608)788-5054				JAY'S HOLDINGS LLC TOWN OF LAYALLE SAUK COUNTY	
			TEAM ENGINEERING		Transportation, Environmental Agribusiness, Municipal and Land Surveying		STORM DETAIL 3	

GENERAL NOTES

DETAILS OF CONSTRUCTION, MATERIALS AND WORKMANSHIP NOT SHOWN ON THIS DRAWING SHALL CONFORM TO THE PERTINENT REQUIREMENTS OF THE STANDARD SPECIFICATIONS OR DNR 1057 TRACKOUT CONTROL.

TRACKING PAD SHALL BE INSPECTED DAILY. DEFICIENT AREAS SHALL BE REPAIRED OR REPLACED IMMEDIATELY.

TRACKING PAD TO BE REMOVED AFTER CONSTRUCTION IS COMPLETED.

TRACKING PAD SHALL BE THE FULL WIDTH OF THE EGRESS POINT.

SURFACE WATER MUST BE PREVENTED FROM PASSING THROUGH THE TRACKING PAD. FLOWS SHALL BE DIVERTED AWAY, AROUND OR CONVEYED UNDER THE TRACKING PAD.

CULVERT PIPE OR OTHER BMP USED TO DIVERT WATER AWAY, AROUND OR UNDER THE TRACKING PAD SHALL BE DESIGNED TO CONVEY THE 2 YEAR - 24 HOUR EVENT.

THE COST OF ADDITIONAL BMP TO DIVERT WATER ARE INCIDENTAL TO THE TRACKING PAD BID ITEM.

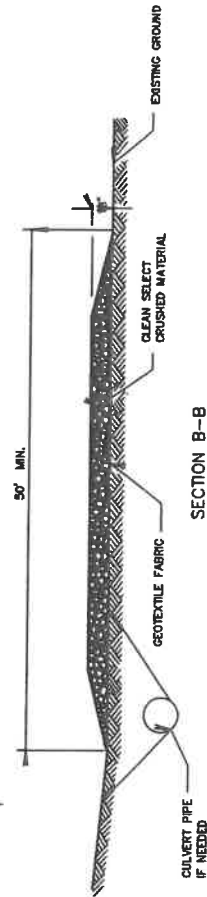
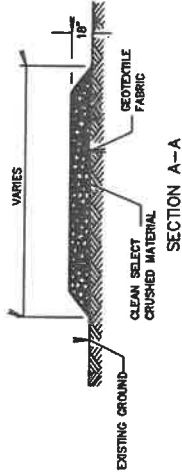
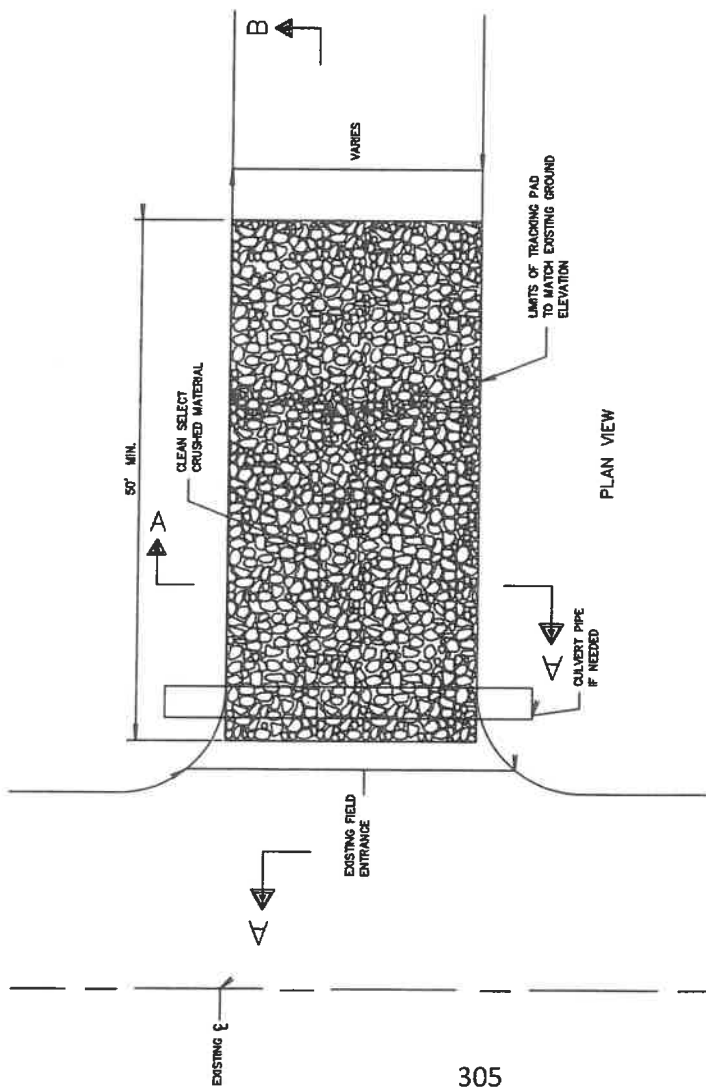

TRACKING PAD

REVISION	DATE	REMARKS	JOB NUMBER	DRAWN	CHECKED	DATE	SHEET NAME	SHEET
			23-2003-1	RTS	JLB	9/27/23	TRACKING PAD	6 OF 9
<p>118 E. Main Street Reedburg, WI 53959 Phone: (608)799-5074</p>								
<p>TRANSPORTATION: Environmental Agriculture: Municipal and Land Surveying</p>								
<p>JAY'S HOLDINGS LLC TOWN OF LAVALLE SAUK COUNTY</p>								

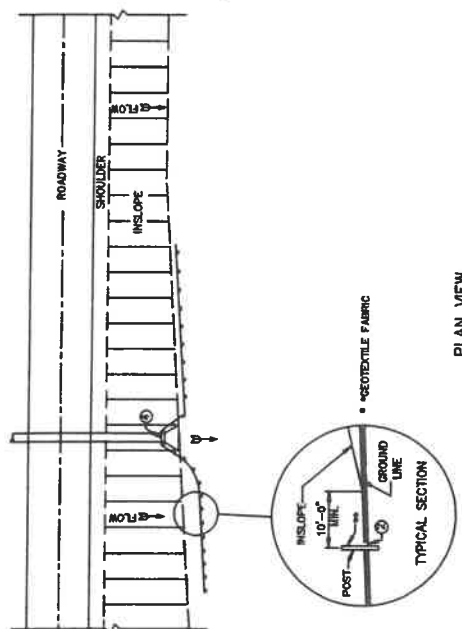

TYPICAL APPLICATION OF SILT FENCE

306

NOTE: ADDITIONAL POST DEPTH OR TIE BACKS MAY BE REQUIRED IN UNSTABLE SOILS

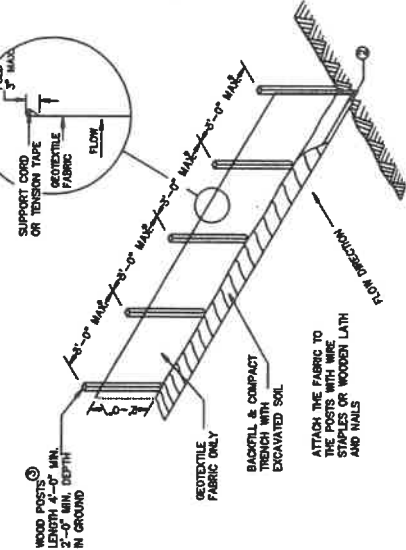

* NOTE: 8'-0\"/>

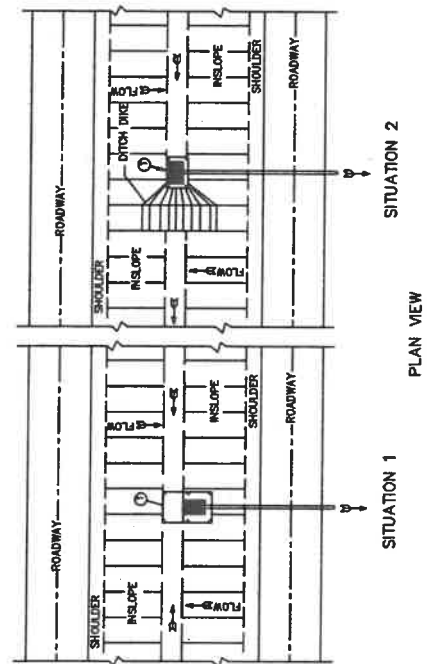

SILT FENCE AT MEDIAN SURFACE DRAINS

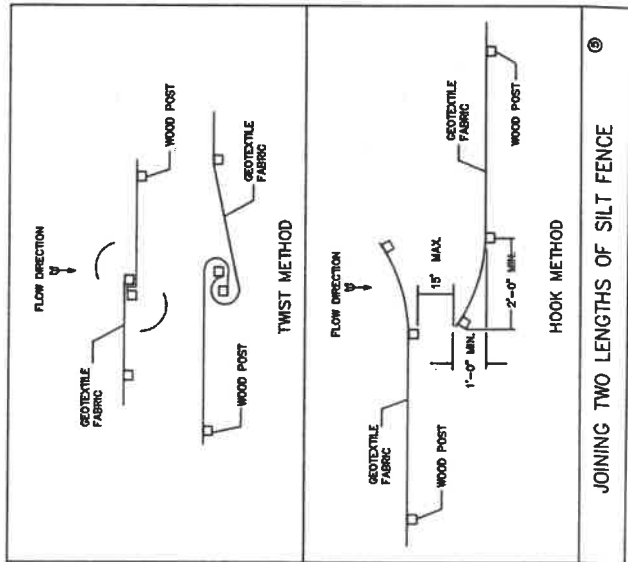

GENERAL NOTES

DETAILS OF CONSTRUCTION NOT SHOWN ON THIS DRAWING SHALL CONFORM TO THE STANDARDS OF THE STANDARD SPECIFICATIONS AND APPLICABLE SPECIAL PROVISIONS.

- 1 HORIZONTAL BRACE REQUIRED WITH 2" X 4" WOODEN FRAME OR EQUIVALENT AT TOP OF POSTS.
- 2 FOR MANUAL INSTALLATIONS THE TRENCH SHALL BE A MINIMUM OF 4" WIDE & 6" DEEP TO BURY AND ANCHOR THE GEOTEXTILE FABRIC. FOLD MATERIAL TO FIT TRENCH AND BACKFILL & COMPACT TRENCH WITH EXCAVATED SOIL.
- 3 WOOD POSTS SHALL BE A MINIMUM SIZE OF 1 1/2" X 1 1/2" OF OAK OR HICKORY.
- 4 SILT FENCE TO EXTEND ACROSS THE TOP OF THE PIPE.
- 5 CONSTRUCT SILT FENCE FROM A CONTINUOUS ROLL IF POSSIBLE BY CUTTING LENGTHS TO AVOID JOINTS. IF A JOINT IS NECESSARY USE ONE OF THE FOLLOWING TWO METHODS: A) OVERLAP THE END POSTS AND TWIST, OR ROTATE, AT LEAST 180 DEGREES; B) HOOK THE END OF EACH SILT FENCE LENGTH.

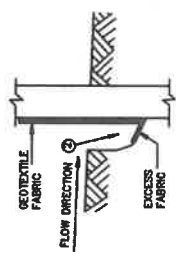

TRENCH DETAIL

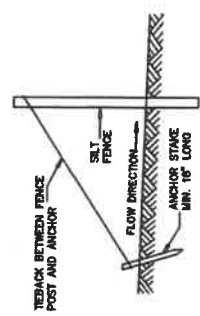

SILT FENCE TIE BACK (WHEN REQUIRED BY THE ENGINEER)

REVISION	DATE	REMARKS	JOB NUMBER	DRAFTER	CHECKED	DATE	SHEET NAME
			25-2003-1	RTS	JLB	9/27/23	SILT FENCE

TRANSPORTATION ENGINEERING AGRICULTURE, MUNICIPAL AND LAND SURVEYING		JAYS HOLDINGS LLC TOWN OF LAVALLÉ SAUK COUNTY	SHEET 7 OF 9
---	--	---	-----------------

DETAIL OF CONSTRUCTION NOT SHOWN ON THIS DRAWING SHALL CONFORM TO THE PERTINENT REQUIREMENTS OF THE STANDARD SPECIFICATIONS AND APPLICABLE SPECIAL PROVISIONS.

SITE PREPARATION
 BEFORE PLACING SEDIMENT LOGS, THE CONTRACTOR SHALL CERTIFY THAT THE SUBGRADE HAS BEEN PROPERLY COMPACTED, GRADED SMOOTH, HAS NO DEPRESSIONS, HOLE, SOFT SPOTS OR UNCOMPACTED AREAS, IS FREE FROM OBSTRUCTIONS SUCH AS TREE ROOTS, PROTRUDING STONES OR OTHER FOREIGN MATTER, AND IS SEEDED AND FERTILIZED ACCORDING TO PROJECT SPECIFICATIONS WHERE APPLICABLE. THE CONTRACTOR SHALL NOT PROCEED UNTIL ALL UNSATISFACTORY CONDITIONS HAVE BEEN REMEDIATED. BY BEGINNING CONSTRUCTION, CONTRACTOR SIGNIFIES THAT THE PRECEDING WORK IS IN CONFORMANCE WITH THE MANUFACTURER'S SPECIFICATION.

CONTRACTOR SHALL FINE GRADE THE SUBGRADE BY HAND DRESSING WHERE NECESSARY TO REMOVE LOCAL DEVIATIONS.

NO VEHICULAR TRAFFIC SHALL BE PERMITTED DIRECTLY ON THE SEDIMENT LOG.

INSTALLATION
 SEDIMENT LOG SHALL BE INSTALLED IN ACCORDANCE TO THE MANUFACTURER'S INSTALLATION GUIDELINES, STAKING PATTERN GUIDE AND DETAILS. THE EXTENT OF SEDIMENT LOGS SHALL BE AS SHOWN ON THE PROJECT DRAWINGS.

SEDIMENT LOG SHOULD BE INSTALLED TO INTERCEPT WATER FLOW AND COLLECT SEDIMENT ON SITE. THEY MAY BE PLACED OVER BARE SOIL OR ON TOP OF EROSION CONTROL BLANKETS. SEDIMENT LOGS ARE TYPICALLY INSTALLED LAYING ON FLAT GROUND AND NOT TRENCHED.

THEY SHALL BE SECURED TO THE SUBGRADE BY WOOD STAKES EVERY TWO LINEAL FEET ACROSS THE LENGTH OF THE SEDIMENT LOG. THE STAKES SHALL BE INTERMIXED WITH THE OUTER MESH OF THE SEDIMENT LOG ONLY AND DRIVEN INTO THE GROUND A MINIMUM OF 16 INCHES ON THE DOWNSTREAM SIDE OF THE SEDIMENT LOG.

SIX INCH AND NINE INCH SEDIMENT LOGS CAN ALSO BE INSTALLED TO THE SUBGRADE WITH WIRE STAPLES. STAPLES SHALL BE INSTALLED PERPENDICULAR FEET ACROSS THE LENGTH ON EACH SIDE OF THE SEDIMENT LOG. THE TWO ROWS OF STAPLES SHALL BE STAGGERED BY ONE FOOT ALONG THE LENGTH OF THE SEDIMENT LOG. ALL STAPLES SHALL BE FULLY INSERTED INTO THE SUBGRADE BELOW THE SEDIMENT LOG.

SEDIMENT LOG INSTALLED IN A SWALE OR CHANNEL BOTTOM SHALL ALLOW THE INSTALLATION TO CONTINUE UP THE SLOPES THREE FEET ABOVE THE ANTICIPATED HIGH WATER MARK AND PERPENDICULAR TO THE FLOW OF WATER.

SPACING OF SEDIMENT LOGS SHALL BE SUCH THAT THE ELEVATION OF THE BOTTOM OF THE SEDIMENT LOG UPSTREAM WILL BE EQUAL TO THE ELEVATION OF THE TOP OF THE DOWNSTREAM LOG. SEDIMENT LOG SHALL REMAIN IN PLACE UNTIL FULLY ESTABLISHED VEGETATION AND ROOT SYSTEMS ARE PRESENT.

WOOD STAKES EVERY 2' NOM. MIN. LENGTH OR EQUIVALENT

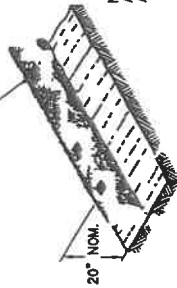

NOTE: ALL DIMENSIONS ARE APPROXIMATE

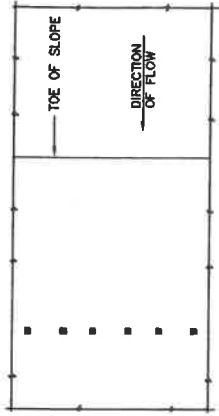

PLAN VIEW

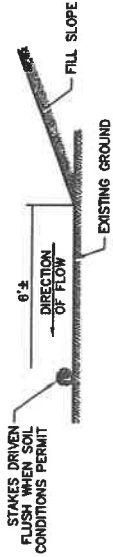

FRONT ELEVATION WHEN EXISTING GROUND SLOPES AWAY FROM FILL SLOPE EROSION LOGS AT TOE OF SLOPE

DETAIL OF SEDIMENT LOG INSTALLATION



PLAN VIEW

STAKES DRIVEN FLUSH WHEN SOIL CONDITIONS PERMIT

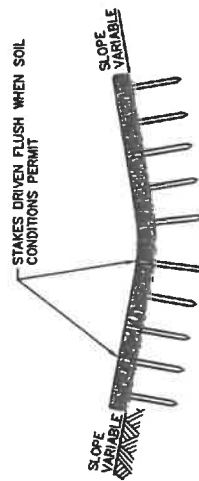

FRONT ELEVATION SEDIMENT LOG ACROSS DITCH BOTTOM

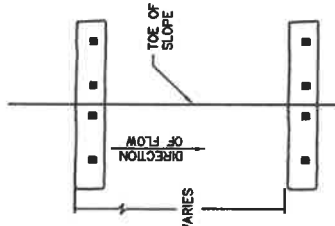

PLAN VIEW

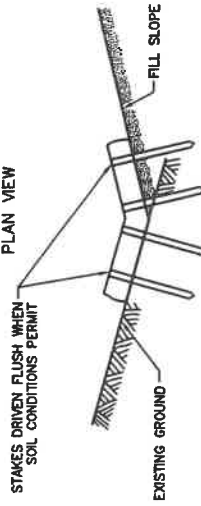

FRONT ELEVATION WHEN EXISTING GROUND SLOPES TOWARD FILL SLOPE

REVISION	DATE	REMARKS	JOB NUMBER	DRAFTER	CHECKED	DATE	SHEET NAME	
			25-2003-1	RTS	JLB	9/27/23	SEDIMENT LOGS	
								TRANSCRIPTION: Emigromphili Municipal and Land Surveying
							118 E. Main Street Reedburg, WI 53059 Phone: (815)758-3074	JAY'S HOLDINGS, LLC TOWN OF LAVALLE SAUK COUNTY
							SEDIMENT LOGS	SHEET 6 OF 9

CONSTRUCTION SITE EROSION CONTROL

PART 1 - GENERAL

1.01 SECTION INCLUDES

- A. FURNISHING, INSTALLING, MAINTAINING, AND REMOVING EROSION AND SEDIMENT CONTROL FACILITIES AND MEASURES.
- B. THE CONTRACTOR IS RESPONSIBLE FOR PROVIDING ALL EROSION CONTROL FACILITIES AND MEASURES NECESSARY TO CONTROL EROSION AND SEDIMENTATION AT THE WORK SITE. THESE MEASURES AND MEASURES MAY OR MAY NOT BE SHOWN ON THE DRAWINGS AND THEIR ABSENCE ON THE DRAWINGS DOES NOT ALLEVIATE THE CONTRACTOR FROM PROVIDING THEM. ANY MEASURES AND FACILITIES SHOWN ON THE DRAWINGS ARE THE MINIMUM ACTIONS REQUIRED.

1.02 REFERENCES

- A. DNR STORM WATER MANAGEMENT TECHNICAL STANDARDS
 - 1038 - SILT FENCE
 - 1037 - STONE TRACKING PAD
 - 1036 - MULCHING FOR CONSTRUCTION SITES
 - 1039 - SEEDING
 - 1040 - STRAW BALE
 - 1042 - SITE EVALUATION FOR STORMWATER INFILTRATION
 - 1004 - BIORETENTION FOR INFILTRATION
- B. WISCONSIN DEPARTMENT OF TRANSPORTATION, EROSION CONTROL, PRODUCT ACCEPTABILITY LISTS FOR MULTIMODAL APPLICATIONS (PAL).

1.03 GENERAL

- A. USE EROSION CONTROL FACILITIES AND MEASURES THROUGHOUT THE DURATION OF THE CONSTRUCTION ACTIVITY TO CONTROL THE MOVEMENT OF SOILS AND TO MINIMIZE THE POTENTIAL FOR EROSION. MAINTAIN THE FACILITIES AND MEASURES UNTIL PERMANENT VEGETATION IS ESTABLISHED.
- B. ERODED SOIL MATERIAL SHALL NOT BE ALLOWED TO LEAVE THE CONSTRUCTION SITE OR TO ENTER A WATERWAY, LAKE OR WETLAND.
- C. THE CONTRACTOR SHALL BE RESPONSIBLE FOR FURNISHING, INSTALLING, AND MAINTAINING THE EROSION CONTROL FACILITIES, AND IN GENERAL, SHALL USE CONSTRUCTION PRACTICES THAT MINIMIZE EROSION.
- D. ERODED MATERIAL THAT HAS LEFT THE CONSTRUCTION SITE SHALL BE COLLECTED AND RETURNED TO THE SITE BY THE CONTRACTOR.
- E. UNEXPECTED CONSTRUCTION SITE TRACKING WITH GRAVELED ROADS, ACCESS DRIVES, AND PARKING AREAS OF SUFFICIENT WIDTH AND LENGTH TO PREVENT SEDIMENT FROM BEING TRACKED ONTO PUBLIC ROADS OR DRIVEWAYS. TRACKING OF SEDIMENT ONTO PUBLIC OR PRIVATE ROADS SHALL BE REMOVED BY STREET CLEANING (NOT FLUSHING) BEFORE THE END OF EACH WORKDAY.

1.04 SCHEDULING AND SCHEDULING

- A. CONSTRUCT AND STABILIZE EROSION CONTROL MEASURES FOR OVERSICONS OR OUTLETS PRIOR TO ANY GRADING OR DISTURBANCE OF THE CONSTRUCTION SITE.
- B. INSTALL SILT FENCE AND STRAW BALE FENCES AND BARRIERS PRIOR TO DISTURBING THE AREA.
- C. TURF AREAS THAT HAVE BEEN COMPLETED TO FINISH GRADE SHALL BE STABILIZED WITH PERMANENT SEEDING WITHIN SEVEN DAYS. TURF AREAS WHERE ACTIVITY HAS CEASED AND THAT WILL REMAIN EXPOSED FOR MORE THAN 20 DAYS BEFORE ACTIVITY RESUMES AND SOIL STOCKPILES SHALL BE STABILIZED WITH TEMPORARY SEEDING OR SOIL STABILIZER.
- D. OTHER EROSION CONTROL MEASURES SHALL BE IN PLACE PRIOR TO DISTURBANCE OF THE CONSTRUCTION SITE AS APPLICABLE.

PART 2 - PRODUCTS

2.01 SILT FENCE

- A. FABRIC SHALL BE A WOVEN OR NONWOVEN POLYESTER, POLYPROPYLENE, STABILIZED NYLON, OR POLYETHYLENE GEOTEXTILE WITH THE FOLLOWING MINIMUM PROPERTIES:
- | PROPERTY | TEST METHOD | REQUIREMENT |
|--|-------------|-------------|
| GRAB TENSILE STRENGTH, LBS./LIN. INCH | ASTM D4832 | 100 |
| CROSS DIRECTION | ASTM D4751 | N/A, 30 |
| MAX. APPARENT OPENING SIZE, LIS. SIEVE PERMISSIVITY, BECZ MIN. | ASTM D4491 | 0.05 |
| MIN. STABILITY AT 150 HRS. % | ASTM D4335 | 70% |

2.02 TEMPORARY SEEDING

- A. ANNUAL OATS, AGRICULTURAL RYE OR WINTER WHEAT.
- B. PROVIDE RYE OR WINTER WHEAT FOR PLANTINGS AFTER SEPTEMBER 1.

2.03 EROSION MAT

- A. ALL EROSION MAT PRODUCTS SHALL BE OF THE CLASS AND TYPE INDICATED AND SHALL BE CHOSEN FROM THE EROSION CONTROL PRODUCT ACCEPTABILITY LISTS.

1.01 SECTION INCLUDES

- B. CLASS 1: A SHORT-TERM DURABLE (SIX MONTHS OR LESS), LIGHT DUTY, ORGANIC MAT, NETTING SHALL BE NON-ORGANIC, PHOTO DEGRADABLE OR BIODEGRADABLE NETTING. THE WEIGHT OF THE NETTING SHALL NOT EXCEED 15% OF THE TOTAL BLANKED WEIGHT. THE NETTING SHALL BE SUFFICIENTLY BONDED TO THE FABRIC MATERIAL TO PREVENT SEPARATION FOR THE LIFE OF THE PRODUCT.
- 1. TYPE A: A NETTED PRODUCT FOR USE ON SLOPES 2:1 OR FLATTER WITH A MINIMUM PRODUCT PERMISSIBLE SHEAR STRESS OF 50 PA (4.0 LB/SQ.F.). NOT TO BE USED IN CHANNELS.
- 2. TYPE B: A DOUBLE NETTED PRODUCT FOR USE ON SLOPES 2:1 OR FLATTER OR IN CHANNELS WITH A MINIMUM PRODUCT PERMISSIBLE SHEAR STRESS OF 70 PA (5.25 LB/SQ.F.).
- 3. TYPE URBAN: A PRODUCT MEETING THE REQUIREMENT FOR EROSION MATS WITH THE FOLLOWING EXCEPTIONS:
 - NETTED PRODUCTS NOT ALLOWED
 - MINIMUM MAT THICKNESS OF 9 MM (3/8 INCH)
 - MINIMUM PRODUCT PERMISSIBLE SHEAR OR GLUE ON 300 MM (12 INCH) MAXIMUM CENTERS IN THE LONGITUDINAL DIRECTION
 - CAPABLE OF WITHSTANDING MODERATE FOOT TRAFFIC WITHOUT TEARING OR PUNCTURING.

THIS PRODUCT SHALL NOT BE USED IN CHANNELS

- C. STAPLES: U-SHAPED NO. 11 GAUGE OR GREATER WIRE WITH A SPAN WIDTH OF ONE TO TWO INCHES AND A LENGTH OF NOT LESS THAN 8 INCHES FOR FIRM SOIL AND 12 INCHES FOR LOOSE SOIL.
- D. ANCHORS: FOR URBAN MAT, ANCHORS SHALL BE BIODEGRADABLE ANCHORS THAT WILL NOT SPLINTER OR SPEAR. THEY SHALL MAINTAIN THEIR ANCHORING CAPABILITY FOR AT LEAST 20 MONTHS.

2.04 SOIL STABILIZER

- A. SOIL STABILIZER SHALL BE A POLYACRYLAMIDE (PAM) AND CALCIUM SOLUTION INTENDED TO REDUCE THE PROBABILITY OF BARE SOILS. THE PRODUCT SHALL ACHIEVE AND MAINTAIN A REDUCTION IN SOIL LOSS INDUCED BY A TWO INCH PER HOUR RAINFALL SIMULATOR.
- B. PAM MIXTURES SHALL BE ENVIRONMENTALLY SAFE, HARMLESS TO FISH, AQUATIC ORGANISMS, WILDLIFE, AND PLANTS. ONLY ANIONIC PAM WILL BE PERMITTED.
- C. ANIONIC PAM IN PURE FORM SHALL HAVE NO MORE THAN 0.05% ACRYLIC MONOMER BY WEIGHT, AS ESTABLISHED BY THE FACTORY CERTIFICATE OF ANALYSIS OR BY A TEST METHOD APPROVED BY THE AGENCY. THE ANIONIC PAM IN PURE FORM SHALL NOT EXCEED 200 POUNDS PER BATCH.
- D. SOIL STABILIZER SHALL BE CPM 2000. CONSTRUCTION FABRICS MATERIALS CORP. (CFM), COTTAGE GROVE, IL OR EQUAL. THE PRODUCT PROVIDED SHALL BE LISTED IN THE WISDOT PAL.

2.05 INLET PROTECTION

- A. TYPE D INLET PROTECTION SHALL BE EQUAL TO THE WISCONSIN DOT TYPE D INLET PROTECTION AS SHOWN ON THE FACILITIES DEVELOPMENT MANUAL DRAWINGS. THE BEST AVAILABLE FABRIC SHALL BE TYPE FF MEETING THE REQUIREMENTS OF THE LATEST EDITION OF PAL.

PART 3 - EXECUTION

3.01 INSTALLATION OF DIMENSIONS

TEMPORARY DIMENSIONS SHALL BE DESIGNED AND INSTALLED IN ACCORDANCE WITH DNR TECHNICAL STANDARDS 106.

3.02 INSTALLATION OF SILT FENCE AND STRAW BALES

- A. INSTALL SILT FENCE AND STRAW BALE FENCES IN ACCORDANCE WITH THE DRAWINGS.
 - B. SILT FENCE AND STRAW BALE FENCES SHALL BE PLACED ON THE CONTOUR TO THE EXTENT PRACTICABLE. PLACE FENCES PARALLEL TO THE SLOPE WITH THE ENDS OF THE FENCE TURNED UP SLOPE A DISTANCE OF ONE TO TWO FEET, WHERE THE MAXIMUM SIZE OF THE DRAINAGE AREA IS 2.25 ACRES PER 100 FEET OF FENCE LENGTH. THE MAXIMUM SLOPE LENGTH BEHIND THE FENCE SHALL BE A FOLLOWS:
- | SLOPE | SILT FENCE LENGTH |
|------------|-------------------|
| 2% TO 5% | 75 FEET |
| 5% TO 10% | 50 FEET |
| 10% TO 20% | 26 FEET |
| >20% | 15 FEET |

3.03 TEMPORARY SEEDING

- A. APPLY SEED EVENLY AT THE RATE OF ONE POUND PER 1,000 SQUARE FEET. RAKE OR DRAG TO COVER THE SEED TO A DEPTH OF 1/2 INCH. SEED ONLY THE AREAS THAT CAN BE MULCHED IN THE SAME DAY.

3.04 EROSION MAT INSTALLATION

- A. REMOVE STONES, CLDS, STICKS OR OTHER FOREIGN MATERIAL THAT WOULD DAMAGE THE MAT OR INTERFERE WITH THE MAT BEARING COMPLETELY ON THE SURFACE.
- B. INSTALL EROSION MAT IN ACCORDANCE WITH THE MANUFACTURER'S RECOMMENDATIONS.
- C. AFTER SEEDING HAS BEEN COMPLETED, ROLL BLANKETS OUT PARALLEL TO THE DIRECTION OF WATER FLOW. WITH THE NETTING ON TOP, SPREAD THE BLANKETS WITHOUT STRETCHING, MAKING SURE THE FIBERS ARE IN CONTACT WITH THE SOIL. OVERLAP ADJACENT STRIPS IN ACCORDANCE WITH THE MANUFACTURER'S RECOMMENDATIONS. MINIMUM OVERLAP SHALL BE A MINIMUM OF 10 INCHES WITH THE UPGRADE STRIP ON TOP. BURY THE UPGRADE END OF EACH STRIP IN A VERTICAL TRENCH AT LEAST 6 INCHES DEEP.

3.06 DITCH EROSION CONTROL

- A. PERMANENTLY STABILIZE ANY PORTION OF THE SITE WITHIN 7 DAYS OF REACHING FINAL GRADE.

3.07 INSTALLATION OF SOIL IN DITCHES

- A. LAY SOIL SO THAT JOINTS OF ADJUTING ENDS OF STRIPS ARE NOT CONTIGUOUS. LAY EACH STRIP SNUGLY AGAINST THE PREVIOUS LAY STRIP.
- B. ROLL OR FIRMLY TAMP SOIL TO PRESS THE SOIL INTO THE UNDERLYING SOIL.
- C. TURN THE UPPER EDGES OF THE STRIPS INTO THE SOIL.
- D. STAKE STRIPS ALONG THE LONGITUDINAL AXIS AT 18-INCH INTERVALS AND NEAR THE TOP EDGE OF THE APPROXIMATELY 12 INCH ABOVE SOIL SURFACE.

3.08 INSTALLATION OF OTHER FACILITIES

- A. INLET PROTECTION BARRIERS, CHANNEL STABILIZATION, GRASSED WATERWAYS, ROCK LINED WATERWAYS, SEDIMENT TRAPS, SEDIMENT BASINS, AND OTHER FORMS OF EROSION CONTROL MEASURES SHALL BE DESIGNED AND INSTALLED IN ACCORDANCE WITH DNR STORM WATER MANAGEMENT TECHNICAL STANDARDS.
- B. MAINTENANCE
 - A. INSPECT OR PERCUSUS WITHIN 24 HOURS AFTER EACH RAINFALL EVENT OR DAILY DURING PERIODS OF PROLONGED RAINFALL, UNTIL THE VEGETATIVE COVER IS ESTABLISHED. MAKE NECESSARY REPAIRS IMMEDIATELY.
 - B. INSPECT SILT FENCE FENCES AND BARRIERS WITHIN 24 HOURS AFTER EACH RAINFALL EVENT OR DAILY DURING PERIODS OF PROLONGED RAINFALL. NECESSARY REPAIRS SHALL BE MADE IMMEDIATELY. IMMEDIATELY REMOVE SEDIMENT DEPOSITS WHEN DEPOSITS REACH ONE-HALF THE HEIGHT OF THE FENCE. FOLLOW MANUFACTURER'S RECOMMENDATIONS FOR REPLACING FABRIC DUE TO WEATHERING.
 - C. INSPECT STRAW BALE FENCES AND BARRIERS WITHIN 24 HOURS AFTER EACH RAINFALL EVENT OR DAILY DURING PERIODS OF PROLONGED RAINFALL. NECESSARY REPAIRS OR REPLACEMENT SHALL BE MADE IMMEDIATELY. REMOVE SEDIMENT DEPOSITS WHEN DEPOSITS REACH ONE-THIRD THE HEIGHT OF THE BALES. REPLACE BALES AFTER THREE MONTHS.
 - D. INSPECT ALL SEEDINGS, SOIL MULCHES, MATS AND NETS WITHIN 24 HOURS AFTER EACH RAINFALL EVENT OR DAILY DURING PERIODS OF PROLONGED RAINFALL. ADDITIONAL MULCH, NETTING OR MATTING SHALL BE APPLIED IMMEDIATELY AS NECESSARY TO MAINTAIN VEGETATIVE COVER. WATER SEEDING AND SOIL WHEN NECESSARY TO PROMOTE ESTABLISHMENT.
 - E. ALL OTHER SOIL EROSION CONTROL MEASURES SHOULD BE INSPECTED AND REPAIRED IMMEDIATELY IF REQUIRED. WITHIN 24 HOURS AFTER EACH RAINFALL EVENT OR DAILY DURING PERIODS OF PROLONGED RAINFALL.

3.10 REMOVAL

- A. AFTER FINAL VEGETATION IS ESTABLISHED, REMOVE BALES, SILT FENCES, AND OTHER EROSION CONTROL FACILITIES. RESTORE AREAS DISTURBED BY THE REMOVALS.

3.05 SOIL STABILIZER

- D. STAKE THE MAT STRIPS IN ACCORDANCE WITH THE MANUFACTURER'S RECOMMENDATIONS. STAKE LONGITUDINALLY, OVERLAP AND BUTTER EDGES AT MAXIMUM INTERVALS OF 2 FEET. STAKE STRIP ENDS AT MAXIMUM 18 INCHES SPACING THROUGHOUT THE MAT AT MAXIMUM 3 FOOT INTERVALS. RIGHT STAPLES FLUSH WITH THE GROUND SURFACE.

3.06 SOIL STABILIZER

- A. THE MANUFACTURER SHALL PROVIDE DETAILED WRITTEN INSTRUCTIONS ON THE STORAGE, MIXING, AND APPLICATION PROCEDURES.
- B. THE SOIL STABILIZER MAY BE APPLIED BY MIXING WITH WATER AND SPRAYING OR BY DRY SPREADING.
- C. APPLICATIONS RATES, RATES ARE FOR WET APPLICATION. RATES FOR DRY APPLICATION MAY NEED TO BE ADJUSTED IN ACCORDANCE WITH THE RECOMMENDATIONS OF THE MANUFACTURER.

3.07 SOIL STABILIZER

SLOPE	POUNDS/ACRE
1 TO 1	16
1 1/2 TO 1	20
2 TO 1	25

- D. THE MAXIMUM APPLICATION RATE SHALL NOT EXCEED 2000 POUNDS PER ACRE PER YEAR.
- E. DO NOT APPLY WITHIN 30 FEET OF A BODY OF WATER (I.E. LAKE, RIVER, STORMWATER POND).
- F. INSTALL PERMETER CONTROL AROUND STOCKPILES AND STABILIZE STOCKPILES THAT WILL REMAIN INACTIVE FOR 7 DAYS OR LONGER.
- G. TEMPORARILY STABILIZE DISTURBED AREAS THAT WILL REMAIN INACTIVE FOR 14 DAYS.
- H. PERMANENTLY STABILIZE ANY PORTION OF THE SITE WITHIN 7 DAYS OF REACHING FINAL GRADE.

3.08 DITCH EROSION CONTROL

- A. THE FOLLOWING EROSION CONTROL MEASURES ARE MINIMUM REQUIREMENTS FOR ALL DITCHES. THE DRAWINGS MAY INCLUDE MORE SPECIFIC MEASURES.

SLOPE RANGE	DITCH EROSION CONTROL MEASURES	BALE CHECKS
0% - 1%	METHOD: SEED AND MULCH	NONE
1% - 2%	SEED AND MULCH WITH EROSION MAT	1% EVERY 200'
2% - 3%	STRAWED SOIL	2% EVERY 100'
3% - 4%	STRAWED SOIL WITHIN REPAIR AS SPECIFIED BY ENGINEER OR ON DRAWINGS	EVERY 75' FOR SOIL

3.09 INSTALLATION OF OTHER FACILITIES

- A. LAY SOIL SO THAT JOINTS OF ADJUTING ENDS OF STRIPS ARE NOT CONTIGUOUS. LAY EACH STRIP SNUGLY AGAINST THE PREVIOUS LAY STRIP.
- B. ROLL OR FIRMLY TAMP SOIL TO PRESS THE SOIL INTO THE UNDERLYING SOIL.
- C. TURN THE UPPER EDGES OF THE STRIPS INTO THE SOIL.
- D. STAKE STRIPS ALONG THE LONGITUDINAL AXIS AT 18-INCH INTERVALS AND NEAR THE TOP EDGE OF THE APPROXIMATELY 12 INCH ABOVE SOIL SURFACE.

3.10 INSTALLATION OF OTHER FACILITIES

- A. INLET PROTECTION BARRIERS, CHANNEL STABILIZATION, GRASSED WATERWAYS, ROCK LINED WATERWAYS, SEDIMENT TRAPS, SEDIMENT BASINS, AND OTHER FORMS OF EROSION CONTROL MEASURES SHALL BE DESIGNED AND INSTALLED IN ACCORDANCE WITH DNR STORM WATER MANAGEMENT TECHNICAL STANDARDS.
- B. MAINTENANCE
 - A. INSPECT OR PERCUSUS WITHIN 24 HOURS AFTER EACH RAINFALL EVENT OR DAILY DURING PERIODS OF PROLONGED RAINFALL, UNTIL THE VEGETATIVE COVER IS ESTABLISHED. MAKE NECESSARY REPAIRS IMMEDIATELY.
 - B. INSPECT SILT FENCE FENCES AND BARRIERS WITHIN 24 HOURS AFTER EACH RAINFALL EVENT OR DAILY DURING PERIODS OF PROLONGED RAINFALL. NECESSARY REPAIRS SHALL BE MADE IMMEDIATELY. IMMEDIATELY REMOVE SEDIMENT DEPOSITS WHEN DEPOSITS REACH ONE-HALF THE HEIGHT OF THE FENCE. FOLLOW MANUFACTURER'S RECOMMENDATIONS FOR REPLACING FABRIC DUE TO WEATHERING.
 - C. INSPECT STRAW BALE FENCES AND BARRIERS WITHIN 24 HOURS AFTER EACH RAINFALL EVENT OR DAILY DURING PERIODS OF PROLONGED RAINFALL. NECESSARY REPAIRS OR REPLACEMENT SHALL BE MADE IMMEDIATELY. REMOVE SEDIMENT DEPOSITS WHEN DEPOSITS REACH ONE-THIRD THE HEIGHT OF THE BALES. REPLACE BALES AFTER THREE MONTHS.
 - D. INSPECT ALL SEEDINGS, SOIL MULCHES, MATS AND NETS WITHIN 24 HOURS AFTER EACH RAINFALL EVENT OR DAILY DURING PERIODS OF PROLONGED RAINFALL. ADDITIONAL MULCH, NETTING OR MATTING SHALL BE APPLIED IMMEDIATELY AS NECESSARY TO MAINTAIN VEGETATIVE COVER. WATER SEEDING AND SOIL WHEN NECESSARY TO PROMOTE ESTABLISHMENT.
 - E. ALL OTHER SOIL EROSION CONTROL MEASURES SHOULD BE INSPECTED AND REPAIRED IMMEDIATELY IF REQUIRED. WITHIN 24 HOURS AFTER EACH RAINFALL EVENT OR DAILY DURING PERIODS OF PROLONGED RAINFALL.

3.10 REMOVAL

- A. AFTER FINAL VEGETATION IS ESTABLISHED, REMOVE BALES, SILT FENCES, AND OTHER EROSION CONTROL FACILITIES. RESTORE AREAS DISTURBED BY THE REMOVALS.

				Transportation, Environmental, Agricultural, Municipal and Land Surveying			
118 E. Main Street Reedburg, WI 53959 Phone: (608)788-5074				EC NOTES			
JAY'S HOLDINGS LLC TOWN OF LAVALLE SAUK COUNTY				EC NOTES			
REVISION	DATE	REMARKS	JOB NUMBER	DRAWER	CHECKED	DATE	SHEET NAME
			25-2003-1	RYS	JLB	9/27/23	EC NOTES
							SHEET 9 OF 9

SITE ADDRESS:

**JAY'S HOLDINGS LLC
STORAGE BUILDINGS 1 & 2
E3350 MINICREEK ROAD
LAVALLE, WI 53941**

COUNTY LOCATION: WAUWATOSH
 PROJECT TYPE: NEW BUILDING
 BUILDING AREA: 60' X 107' (6400 SQ FT) CENTRAL BUILDING
 MEAN ROOF HEIGHT: 3'-4"
 NO. STORIES: ONE STORY
 OCCUPANCY GROUP: S1 STORAGE
 CONSTRUCTION TYPE: 10
 UNSPRINKLERED, UNHEATED
 OCCUPANT LOAD: 0
 REQUIRED SEPARATION: N/A
 ALLOWABLE HEIGHT: ONE STORY
 ALLOWABLE BUILDING AREA: 10000 SQ. FT. (AREA INCREASE USED)
 ALLOWABLE UNSPRINKLERED AREA: 10000 SQ. FT.
 ROOF SLOPE: 4/12
 ROOF SURFACE: FLAT (NOT USED)

WIND DESIGN DATA:
 DESIGN PROCEDURE METHOD = ENVELOPE FOR LOW RISE BUILDING
 BASIC WIND SPEED = 90.0
 WIND LOAD RESISTANCE DESIGN AREA = 140 MPPH
 WIND LOAD EXPOSURE CATEGORY = B
 WIND LOAD IMPORTANCE FACTOR, I_w = 1.0
 ADJUSTMENT FACTOR (λ) = 1.00
 COMPONENTS & CLADDING
 PRESSURE (10 SF TRIBUTARY AREA)
 ZONE 1 - 51.7 - 58.0 PMP ZONE 4 - 29.0 - 38.0 PMP
 ZONE 2 - 51.7 - 58.0 PMP ZONE 5 - 29.0 - 38.0 PMP
 ZONE 3 - 51.7 - 58.0 PMP
 SIMPLIFIED MWFRS (METHOD 2)
 ZONE A - 58.0 PMP ZONE G - 41.0 PMP
 ZONE B - 58.0 PMP ZONE H - 41.0 PMP
 ZONE C - 58.0 PMP
 ZONE D - 40.0 PMP
 ZONE E - 38.0 PMP
 ZONE F - 41.0 PMP

PRESUMPTIVE SOIL DATA:
 SOIL TYPE: ST LOAM (CL)
 SOIL LOAD BEARING VALUE: 800 PSF
 SOIL LATERAL PRESSURE: 100 PSF

SNOW DESIGN DATA:
 GROUND SNOW LOAD, P_g = 30.0 PSF
 SNOW LOAD IMPORTANCE FACTOR, I_s = 1.0
 SNOW LOAD EXPOSURE FACTOR, C_e = 1.0
 SLOPED ROOF/FLAT ROOF FACTOR, C_d = 1.0
 ROOF THERMAL FACTOR, C_t = 1.0
 ROOF SNOW LOAD (BALANCED) = 24.0 PSF
 ROOF SNOW LOAD (UNBALANCED)
 ROOF WINDWARD = 24.0 PSF LEeward

EARTHQUAKE DESIGN DATA:
 SEISMIC IMPORTANCE FACTOR, I_e = 1.0
 S (1 SEC. PERIOD SPECTRAL ACCELERATIONS) = 0.098
 S1 (1 SEC. PERIOD SPECTRAL ACCELERATIONS) = 0.098
 S4 (SHORT PERIOD SPECTRAL RESPONSE COEF) = 0.098
 S4 (1 SEC. PERIOD SPECTRAL RESPONSE COEF) = 0.098
 SITE CLASS (ASSUMED): D
 SEISMIC DESIGN CATEGORY: A
 BASIC SEISMIC FORCE RESISTING SYSTEM:
 UC LIGHT FRAME WALLS WITH BRICK PANELS
 DESIGN BASE SHEAR = 2,860 LB
 RESPONSE MODIFICATION FACTOR(S), R = 6.0
 ANALYSIS PROCEDURE USED: ENVELOPE

UNIFORM BUILDING HEIGHTS	MINIMUM WIND SPEED PER UNIT OF AREA	MINIMUM WIND SPEED PER UNIT OF AREA	MINIMUM WIND SPEED PER UNIT OF AREA	MINIMUM WIND SPEED PER UNIT OF AREA
10 FT	30.0	30.0	30.0	30.0
15 FT	30.0	30.0	30.0	30.0
20 FT	30.0	30.0	30.0	30.0
25 FT	30.0	30.0	30.0	30.0
30 FT	30.0	30.0	30.0	30.0
35 FT	30.0	30.0	30.0	30.0
40 FT	30.0	30.0	30.0	30.0
45 FT	30.0	30.0	30.0	30.0
50 FT	30.0	30.0	30.0	30.0
55 FT	30.0	30.0	30.0	30.0
60 FT	30.0	30.0	30.0	30.0
65 FT	30.0	30.0	30.0	30.0
70 FT	30.0	30.0	30.0	30.0
75 FT	30.0	30.0	30.0	30.0
80 FT	30.0	30.0	30.0	30.0
85 FT	30.0	30.0	30.0	30.0
90 FT	30.0	30.0	30.0	30.0
95 FT	30.0	30.0	30.0	30.0
100 FT	30.0	30.0	30.0	30.0



HARTJE LUMBER, INC.
 24528A SCHULTE ROAD
 P.O. BOX 188
 LAVALLE, WI 53941
 PHONE: 800-362-8898 OR 608-985-7207

GENERAL NOTES AND SPECIFICATIONS

1. SITE NOTES: THE BUILDING SITE SHALL BE GRADED TO PROVIDE DRAINAGE AWAY FROM BUILDING.
2. CONCRETE FINISHES: 4000 PSI IN 28 DAYS. SLUMP NOT OVER 4". READY FOR CONCRETE TO REST WITH OIL.
3. LUMBERS: ALL LUMBERS TO BE S4S #1 SPRUCE/PINE/FIR OR EQUAL UNDER NOTED DIMENSIONS OR PLAN.
4. JOIST SPACING: SHALL BE PROVIDED OVER ALL DECK DOORS AND SHALL BE THROUGH JOIST JOISTS OF THE UNCOMMON ENCLOSED CONCRETE BUILDING CODE.
5. FINISHES OF INTERIOR WALLS: THE INTERIORS OF FLOOR LIGHTING SHALL NOT BE LESS THAN 1 FOOTCANDLE OF ILLUMINATION AT THE BUILDING SURFACE LEVEL PER 2015 INTERNATIONAL BUILDING CODE.
6. FINISHES OF INTERIOR CEILING: DOWN, GYM, STAIRWAYS AND RAMP SHALL BE FINISHED TO MEET THE REQUIREMENTS OF THE UNCOMMON ENCLOSED CONCRETE BUILDING CODE.
7. ELEVATIONS: IS NOT PART OF THE DRAWING AND SHALL BE INSTALLED IN ACCORDANCE WITH ALL STATE AND LOCAL CODES.
8. MECHANICAL, VENTILATION AND AIR-CONDITIONING: IS NOT PART OF THE DRAWING AND SHALL BE INSTALLED IN ACCORDANCE WITH ALL STATE AND LOCAL CODES.
9. ELECTRICAL: IS NOT PART OF THE DRAWING AND SHALL BE INSTALLED IN ACCORDANCE WITH ALL STATE AND LOCAL CODES.
10. OWNER: TO PROVIDE BULLETPROOF RISK INSURANCE.
11. EXHAUSTION FROM PLANS: THESE SHALL BE NO CREATION FROM THESE PLANS WITHOUT THE WRITTEN CONSENT OF HARTJE LUMBER, INC.
12. FIRE RESISTANCE: FIRE RESISTANCE SHALL BE PROVIDED BY THE OWNER PER (SECTION AND MATERIAL) PER IBC 703.5.1.
13. STRUCTURAL DESIGN: BUILDING DESIGN SHALL BE IN ACCORDANCE WITH THE DESIGN OF THE SOIL, INTERNATIONAL BUILDING CODE BY LOCAL AMENDMENTS, BY MEANS OF DESIGN PROFESSIONAL.
14. ALL CONSTRUCTION SHALL BE IN ACCORDANCE WITH THE REQUIREMENTS OF THE 2015 INTERNATIONAL BUILDING CODE BY LOCAL AMENDMENTS, IN ACCORDANCE WITH THE INTERNATIONAL BUILDING CODE FOR ANY ENCLOSED MECHANICAL DESIGN.
15. OWNER IS RESPONSIBLE FOR OBTAINING ANY AND ALL NECESSARY PERMITS IN ACCORDANCE WITH THE INTERNATIONAL BUILDING CODE FOR ANY ENCLOSED MECHANICAL DESIGN.

SHEET INDEX	
NO.	TITLE PAGE
1	OF 7
2	OF 7
3	OF 7
4	OF 7
5	OF 7
6	OF 7
7	OF 7

PROJECT: NEW CONSTRUCTION
 SHEET: 1 OF 7
 JOB NO.: 2336
 DRAWN BY: JAY'S HOLDINGS LLC
 CHECKED BY: 608 COUNTY ROAD E
 DATE: 9/2/20
 PROJECT ADDRESS: STORAGE BUILDING

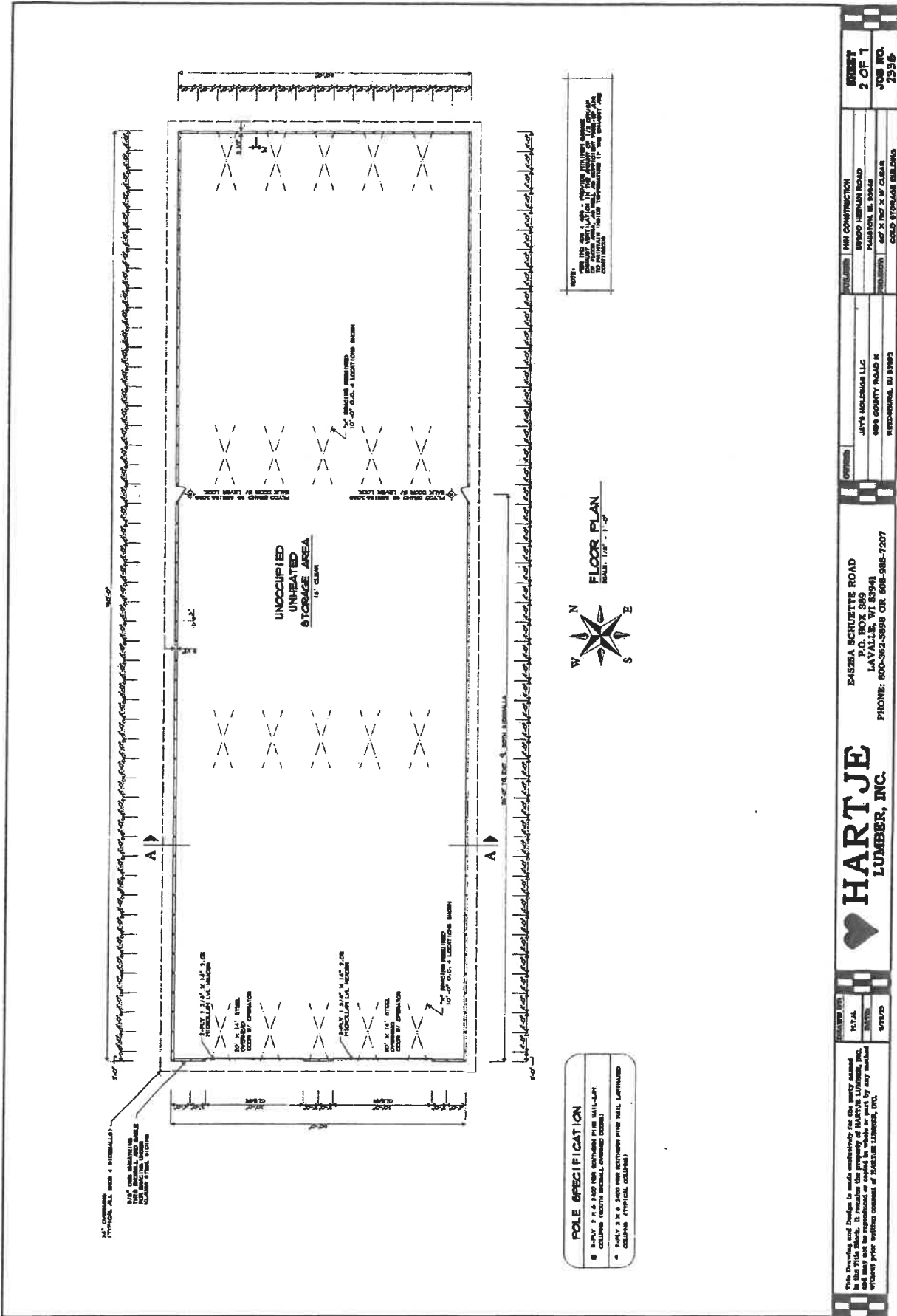

NOTE: SEE 1405 - REVISION NUMBER ABOVE FOR ALL DIMENSIONS. ALL DIMENSIONS ARE TO CENTER UNLESS OTHERWISE NOTED. ALL DIMENSIONS ARE TO CENTER UNLESS OTHERWISE NOTED.



ROLE SPECIFICATION

B - BAY 3 21/4\"/>

A - LATHING & 2\"/>

<p>This Drawing and Design is made exclusively for the party named in the Title Block. It remains the property of HARTJE LUMBER, INC. and may not be reproduced or used in whole or part by any method without prior written consent of HARTJE LUMBER, INC.</p>		<p>DATE: 07/15/2015</p> <p>BY: [Signature]</p>	
<p>HARTJE LUMBER, INC.</p> <p>84582A SCHWITZES ROAD P.O. BOX 33 LAVALLUE, WI 53941 PHONE: 800-362-5538 OR 608-985-7207</p>		<p>OWNER: JAY'S HOLDINGS LLC 608 COUNTY ROAD E RESCORONA, WI 53954</p>	
<p>CONTRACT NO.: 15-001</p>		<p>CONTRACTOR: HWI CONSTRUCTION 8940 HERMAN ROAD MADISON, WI 53748 TEL: 608-785-1100 COLD STORAGE BUILDING</p>	
<p>SHEET NO.: 2 OF 1</p>		<p>JOB NO.: 2536</p>	

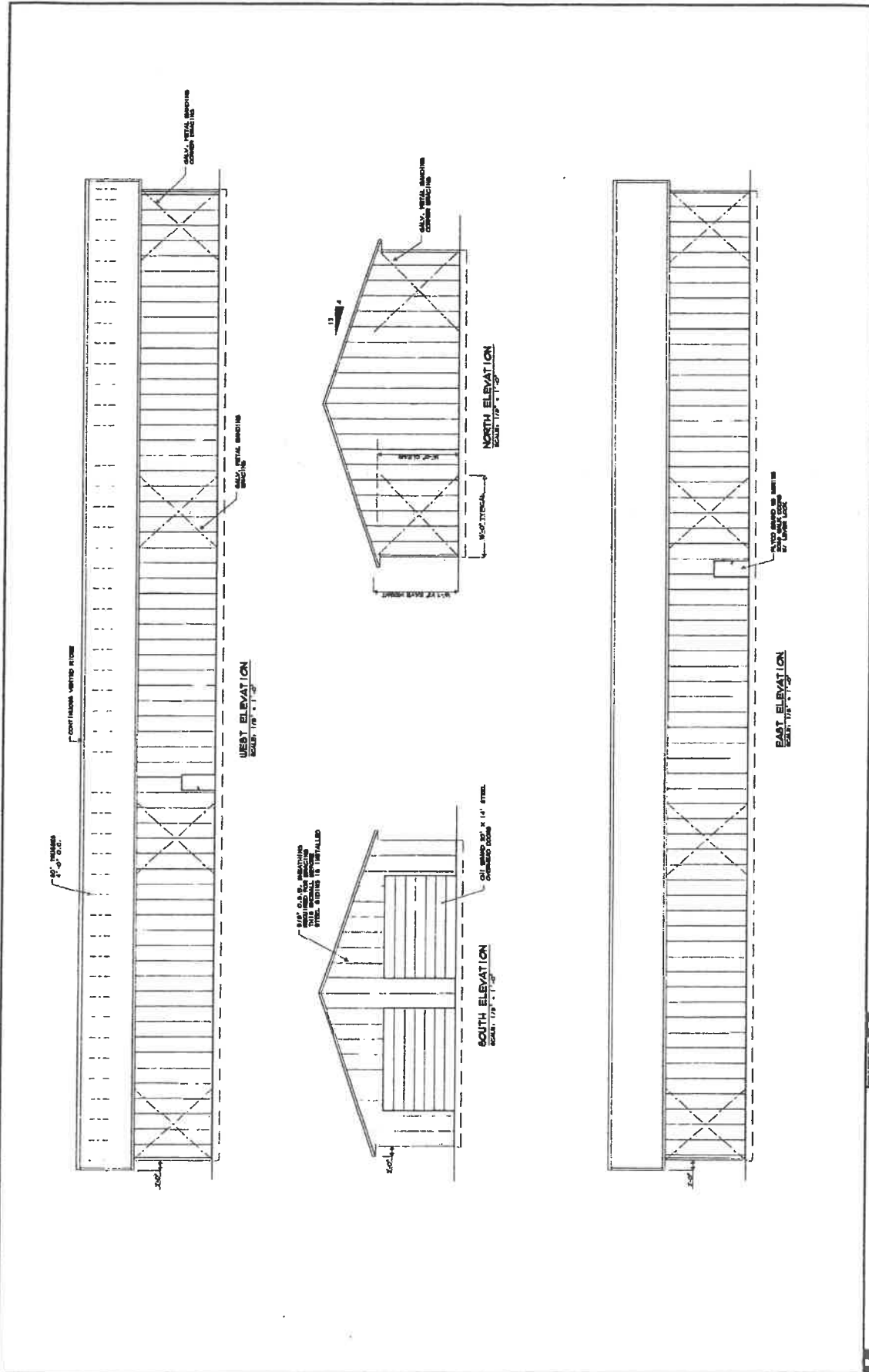

This Drawing and Design is made exclusively for the party named above and is the property of HARTJE LUMBER, INC. and may not be reproduced or used for any other project without prior written consent of HARTJE LUMBER, INC.

DATE: 9/7/28

PROJECT: HARTJE LUMBER, INC.

OWNER: JAY'S HOLDINGS LLC
8888 COUNTY ROAD K
PISCATAWAY, NJ 08859

CONTRACTOR: HHI CONSTRUCTION
8800 IRISHMAN ROAD
HAMTON, IL 62946

PROJECT: 207' X 167' X 16' CLEAR
COLD STORAGE BUILDING

PROJECT NO.: 2336

SHEET NO.: 3 OF 7

HARTJE LUMBER, INC.

24525A SCHUETTE ROAD
P.O. BOX 389
LAVALLE, WI 53941
PHONE: 800-862-5898 OR 608-965-7207

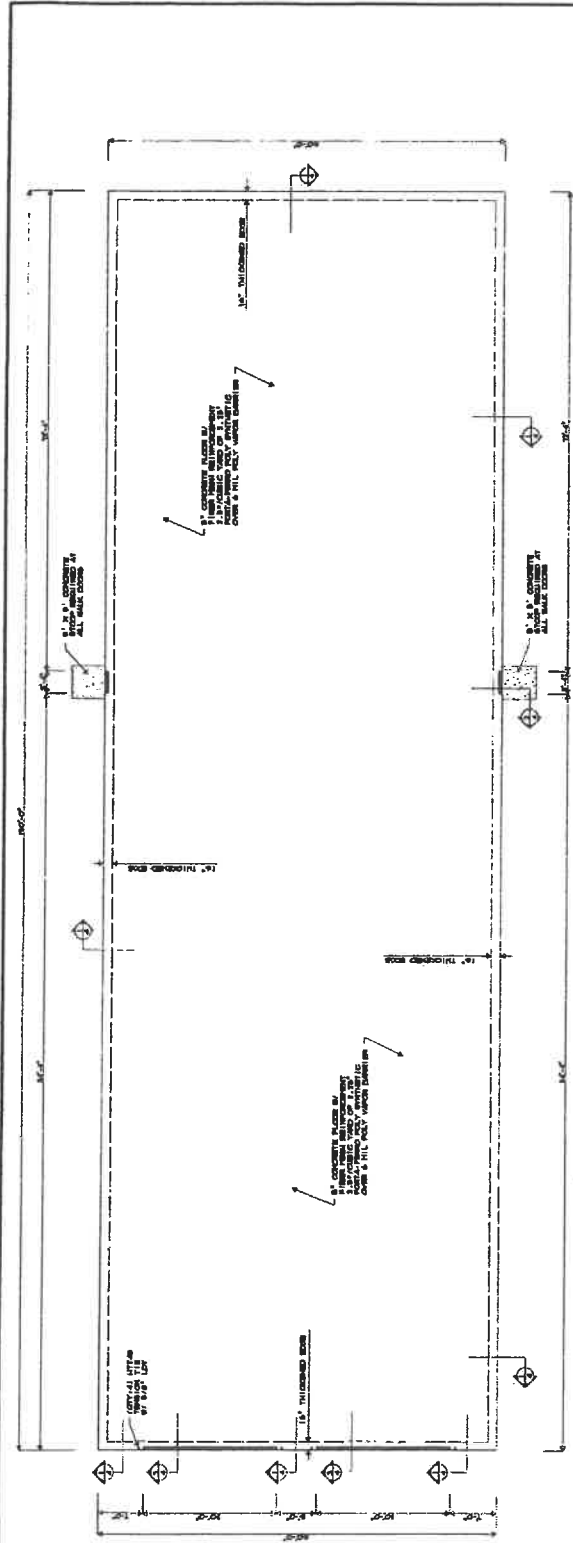

NOTE: CONCRETE SHALL BE A MINIMUM OF 150-120 PSI.

NOTE: 1) 1/2" x 4" x 12" REBAR ALL SPACING AND COVER SHALL BE AS SHOWN UNLESS OTHERWISE NOTED. 2) 3" CONCRETE PLACEMENT SHALL BE AS SHOWN UNLESS OTHERWISE NOTED. 3) 15' THICKENED EDGE SHALL BE AS SHOWN UNLESS OTHERWISE NOTED. 4) ALL DIMENSIONS ARE TO FACE UNLESS OTHERWISE NOTED. 5) ALL DIMENSIONS ARE TO FACE UNLESS OTHERWISE NOTED. 6) ALL DIMENSIONS ARE TO FACE UNLESS OTHERWISE NOTED. 7) ALL DIMENSIONS ARE TO FACE UNLESS OTHERWISE NOTED.

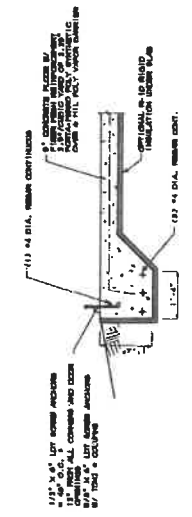

CONCRETE SPECIFICATIONS:

- CONCRETE SHALL BE 150-120 PSI.
- CONCRETE SHALL BE PLACED IN 4" LAYERS.
- CONCRETE SHALL BE PLACED IN 4" LAYERS.
- CONCRETE SHALL BE PLACED IN 4" LAYERS.
- CONCRETE SHALL BE PLACED IN 4" LAYERS.
- CONCRETE SHALL BE PLACED IN 4" LAYERS.
- CONCRETE SHALL BE PLACED IN 4" LAYERS.
- CONCRETE SHALL BE PLACED IN 4" LAYERS.
- CONCRETE SHALL BE PLACED IN 4" LAYERS.
- CONCRETE SHALL BE PLACED IN 4" LAYERS.

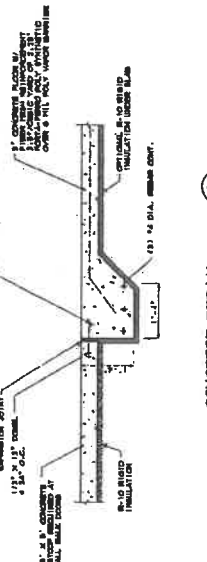

HARTJE LUMBER, INC.		CONCRETE DETAIL (WALK DOOR LOCATIONS) 3	
PROJECT NO.	17474	OWNER	JAY'S HOLDINGS LLC
DATE	07/20	ADDRESS	809 COUNTY ROAD K BROOKSHIRE, WI 53005
This drawing and Design is made exclusively for the party named above and may not be reproduced or copied in whole or part by any method without prior written consent of HARTJE LUMBER, INC.		PROJECT	NEW CONSTRUCTION
		LOCATION	UNION ARMY ROAD WASHINGTON, WI 53095
		FOUNDATION	30" x 12" x 8" CLEAR
			COLD STORAGE WAREHOUSE
		SHEET	4 OF 7
		NO. NO.	2336

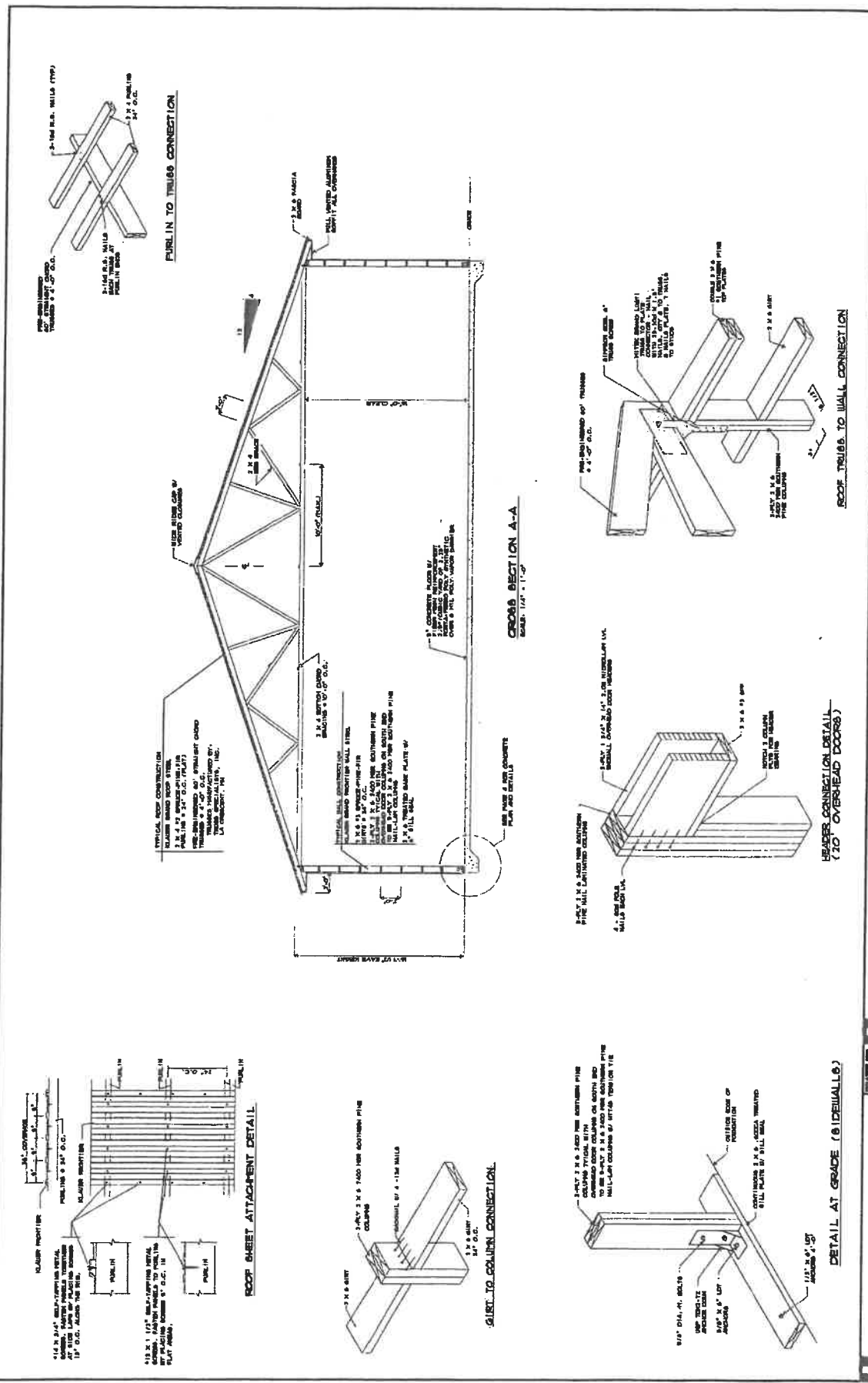

<p>This Drawing and Design is made exclusively for the party named hereon and is not to be reproduced or copied in whole or in part without prior written consent of HARTJE LUMBER, INC.</p>		<p>DATE: 11/27/88</p>
<p>PROJECT NO. 2336</p>	<p>CLIENT: HARTJE LUMBER, INC.</p>	<p>SCALE: 1/4" = 1'-0"</p>
<p>DESIGNER: JAY'S LUMBER, LLC</p>	<p>PROJECT: 800 COUNTY ROAD K</p>	<p>CONTRACTOR: HHI CONSTRUCTION</p>
<p>ADDRESS: HOSKINGDALE, WI 53949</p>	<p>PHONE: 800-362-5898 OR 608-965-7207</p>	<p>ADDRESS: 800 KEMAN ROAD</p>
<p>PROJECT: HOSKINGDALE, WI 53949</p>	<p>PROJECT: 800 COUNTY ROAD K</p>	<p>PROJECT: HOSKINGDALE, WI 53949</p>
<p>PROJECT: HOSKINGDALE, WI 53949</p>	<p>PROJECT: HOSKINGDALE, WI 53949</p>	<p>PROJECT: HOSKINGDALE, WI 53949</p>



Land Resources & Environment
 Department
 505 Broadway, Ste. 248
 Baraboo, Wisconsin 53913
 Phone: (608) 355-3245
 Fax: (608) 355-3292
 www.co.sauk.wi.us

Application Accepted: 10-6-23
 Accepted By: Will C
 Petition Number: 14-2023
 Current Zoning: Exclusive Ag
 Proposed Zoning: Agriculture
 Committee Hearing Date: 11-28-23
 County Board Date: 12-19-23
 Supervisor District #: 25

Zoning Map Amendment (Rezone) Application

General Information

Property Owner Name: Clayton Yoder Home Phone: 608-495-1020
 Mailing Address: 56911 CR D Cell Phone: 608-495-1242
 E-mail Address:
 Agent/Applicant Name: Home Phone:
 Mailing Address: Cell Phone:
 E-mail Address:

Site Information

Site Address: 56911 CR D Loganville, WI 53943
 Parcel ID: 040-0727-10000
 Property Description: NW 1/4 NE 1/4 Section 35, T 11 N, R 4 E, Current Zoning: EA
 Town of: Westfield
 Overlay District: Shoreland Floodplain Airport
 Current Use:

Existing Structures/Improvements: House, Barn, Garage

Proposed Zoning

Proposed Ordinance Section	Proposed Zoning/Use Description
7150	Agriculture (AG)

Describe specifically the nature of the request (be sure to list all proposed uses of the property). What do you plan to do? Please attach additional sheets, if necessary.

refer to letter

CR # 3981-250⁰
 R. # A10607

To Whomever it may concern,
My desire is to have a family business at home to work with my 6 children living here at home. This is an ideal opportunity to instill work ethics to the younger generation that will benefit them for life. This is why I desire to have a Professional Dog Facility to teach my children the benefits of working & playing with canines in a way that will encourage them in proper relationships with people as well which seems to be lacking in this day and age.

We plan on being USDA + State licensed & also work with an attending veterinarian on regular basis with yearly inspections, or more if needed. Plus I go to meetings numerous times a year for more information concerning the improvements of care taking of my canines.

My facility will be totally fenced in for the protection of my canines with plenty of exercise room plus climate controlled indoor access at all times. Canines will be indoors overnight & waste will be disposed of properly every day by clearing or decomposing of fecal matter. Canines will probably be on raised flooring indoors with some solid flooring as well or whatever is required by USDA regulations.

I will also follow township standards on Vegetative buffer plans and will use at least 75% evergreens or more at 20 foot spacing or less. There will be minimum traffic as calls are 90% wholesale and deliveries will be done by myself if done by private sales.

Another one of our goals is to raise healthy puppies for people who desire a life time companion, and are socialized to adapt to any ages of human companions they will be in contact with. Our desire is that our canines go to loving homes where they will be well taken care of.

To Whomever it may concern,

My desire is to have a family business at home to work with my 6 children living here at home. This is an ideal opportunity to instill work ethics to the younger generation that will benefit them for life. This is why I desire to have a Professional Dog Facility to teach my children the benefits of working & playing with canines in a way that will encourage them in proper relationships with people as well which seems to be lacking in this day and age.

We plan on being USDA & State licensed & also work with an attending veterinarian on regular basis with yearly inspections, or more if needed. Plus I go to meetings numerous times a year for more information concerning the improvements of care taking of my canines.

My facility will be totally fenced in for the protection of my canines with plenty of exercise room plus climate controlled indoor access at all-times. Canines will be indoors overnight & waste will be disposed of properly every day by clearing or decomposing of fecal matter. Canines will probably be on raised flooring indoors with some solid flooring as well or whatever is required by USDA regulations.

I will also follow township standards on Vegetative buffer plans and will use at least 75% evergreens or more at 20 foot spacing or less. There will be minimum traffic as sales are 90% wholesale and deliveries will be done by myself if done by private sales.

I plan on having around ³¹⁸50 adult dogs give or take according to USDA and State regulations: for room required per dog.

General Application Requirements

Applications will not be accepted until the applicant has met with department staff to review the application and determine if all the necessary information has been provided. All information from the checklist must be provided to the Department to be considered a complete application. Only complete applications submitted by the deadline will be noticed for a specific hearing date/time.
<input type="checkbox"/> Completed Zoning Map Amendment Application Form.
<input type="checkbox"/> \$500 application fee (non-refundable), payable to Sauk County LRE.
<input type="checkbox"/> Town/County Scheduling Form completed by the applicant and Township.
<input type="checkbox"/> A scaled map of the proposed rezone area (if the property is not vacant the location of buildings, driveways, etc. must be shown).
<input type="checkbox"/> Legal description of the area to be rezoned (CSM, Metes & Bounds description)
<input type="checkbox"/> Any other information as required by the zoning administrator to explain the request.

Zoning Map Amendment Standards

Explain how the proposed rezone is consistent with the overall purpose and intent of the zoning ordinance.

Due to only having 5 acres and trying to support my family on this small acreage I desire to have another business that doesn't impair any ag use as far as raising livestock on land for tillage in any way, and will also protect property value & property tax base in every way.

If rezoning out of an Exclusive Agriculture Zoning District explain how the land is better suited for a use not allowed in the Exclusive Agriculture Zoning District and how the rezoning will not substantially impair or limit future agricultural use of surrounding parcels of land that are zoned for or legally restricted to agricultural use.

As of right now this parcel is not used for ag in any way and will not impair the use of the rest of the property that is being used for livestock and tillage is our own personal garden as 1 portable kennel building for a family business should not impact any surrounding ag uses.

Certification

I certify by my signature that all information presented herein is true and correct to the best of my knowledge. I give permission for the staff of the Sauk County Land Resources & Environment Department to enter my property for the purpose of collecting information to be used as part of the public hearing process. I understand that the rezone fee is a non-refundable, regardless if the rezone is approved or denied. I understand that the fee for this application is only for the rezone request and if permits are required for the project that those will require separate application(s) and/or fee(s). I understand that partial or incomplete applications will be returned to the applicant resulting in the application being removed from the hearing agenda and the submittal deadlines will restart. I further agree to withdraw this application if substantive false or incorrect information has been included.

Applicant/Agent: Clayton Yoder Date: 9-16-23
 Property Owner Signature: Clayton Yoder 319 Date: 9-16-23

Zoning Map Amendment Procedures and Requirements

At the public hearing, the applicant may appear in person or through an agent or an attorney of their choice. The applicant/agent/attorney may present testimony, evidence and arguments in support of the application. All site plans, pictures, etc. become the property of the Land Resources & Environment Department, will remain in the file, and will be public record.

What is a Zoning Map Amendment?

The purpose of a zoning map amendment is to alter, enlarge, or reduce a geographic extent of any zoning district, or to enact a new zoning designation for any particular parcel or real property. A change in zoning allows for different land uses and in some instances, different densities of development. The Land Resources & Environment Committee will recommend approval or disapproval of a rezone to the Sauk County Board of Supervisors in accordance with the standards and criteria set by the zoning ordinance.

Standards and Criteria

In reviewing a Zoning Map Amendment request, the LRE Committee must follow four standards:

- a) The proposed map amendment is consistent with the overall purpose and intent of the zoning ordinance.
- b) The proposed map amendment is consistent with the Sauk County Comprehensive Plan and the Farmland Preservation Plan, if applicable.
- c) Factors have changed from the time of initial ordinance adoption that warrant the map change, or an error, inconsistency, or technical problem administering the zoning ordinance as currently depicted has been observed.
- d) In rezoning land out of any exclusive agriculture district, the agency shall find all of the following, after a public hearing:
 1. The land is better suited for a use not allowed in the exclusive agriculture district.
 2. The rezoning is consistent with the Sauk County Comprehensive Plan.
 3. The rezoning is substantially consistent with the Sauk County Farmland Preservation Plan.
 4. The rezoning will not substantially impair or limit current or future agricultural use of surrounding parcels of land that are zoned for or legally restricted to agricultural use.

Note: Pursuant to Wis. Stat § 91.48(1) A political subdivision (Sauk County) with a certified farmland preservation zoning ordinance may not rezone land out of a farmland preservation zoning district (Exclusive Agriculture) without having the rezoning certified under Wis. Stat § 91.36 and provided that the standards (a) through (d) above are met.

Process

1. Contact the LRE Department to schedule a meeting to review your potential request.
2. Complete the Zoning Map Amendment Application and provide all the supplemental items to the LRE Department by the filing deadline.
3. Review such application with the appropriate staff member to determine completeness.
4. If the application is complete, LRE staff will publish notice of your request for a zoning map amendment in the County's official newspaper noting the location and time of the required public hearing before the LRE Committee. Neighbors, town officials, and affected state agencies will be notified as well.
5. If the Town chooses to review the zoning map amendment request at the Town Planning Commission and Town Board level, you will need to attend such meetings to provide information regarding the request. Please request that copies of minutes/proceedings outlining the Town's recommendation be provided to the LRE Department for the file.
6. A public hearing will be held before the LRE Committee. Either the property owner or designated agent will need to be present at the hearing to provide testimony regarding the request. The LRE Committee must make a decision based only on the evidence that is submitted to it at the time of the hearing. Failure to provide representation may result in denial or postponement of your request.
7. The LRE Committee and Sauk County Board of Supervisors may approve, disapprove, or modify and approve the zoning map amendment request.

Please Note: If a zoning map amendment application is disapproved by the LRE Committee and no appeal is filed, no new zoning map amendment application can be re-submitted for a period of 365 days from the date of the LRE Committee's decision, except on grounds of new evidence or proof of changes of factors found valid by the LRE Committee.

DOCUMENT #: 1245740
 Recorded: 01-25-2023 at 9:00 AM
 BRENT BAILEY
 SAUK COUNTY REGISTER OF DEEDS
 REGISTRAR'S OFFICE
 Sauk Co, WI
 RECEIVED FOR RECORD
 Fee Amount: \$30.00

SAUK COUNTY CERTIFIED SURVEY MAP 7257
 PART OF THE NW 1/4 - NE 1/4 OF SECTION 35, T11N, R4E, TOWN OF WESTFIELD, SAUK COUNTY, WISCONSIN

SURVEYED FOR:
 Homer and Edna Beochy
 175 N. Galbreath Rd.
 Mio, MI 48647

FD. 1 1/2" DIA. IRON ROD
 N 1/4 COR.
 SEC. 35, T11N, R4E
 TIES VERIFIED

FD. HARRISON S/L MON.
 NE COR.
 SEC. 35, T11N, R4E
 TIES VERIFIED

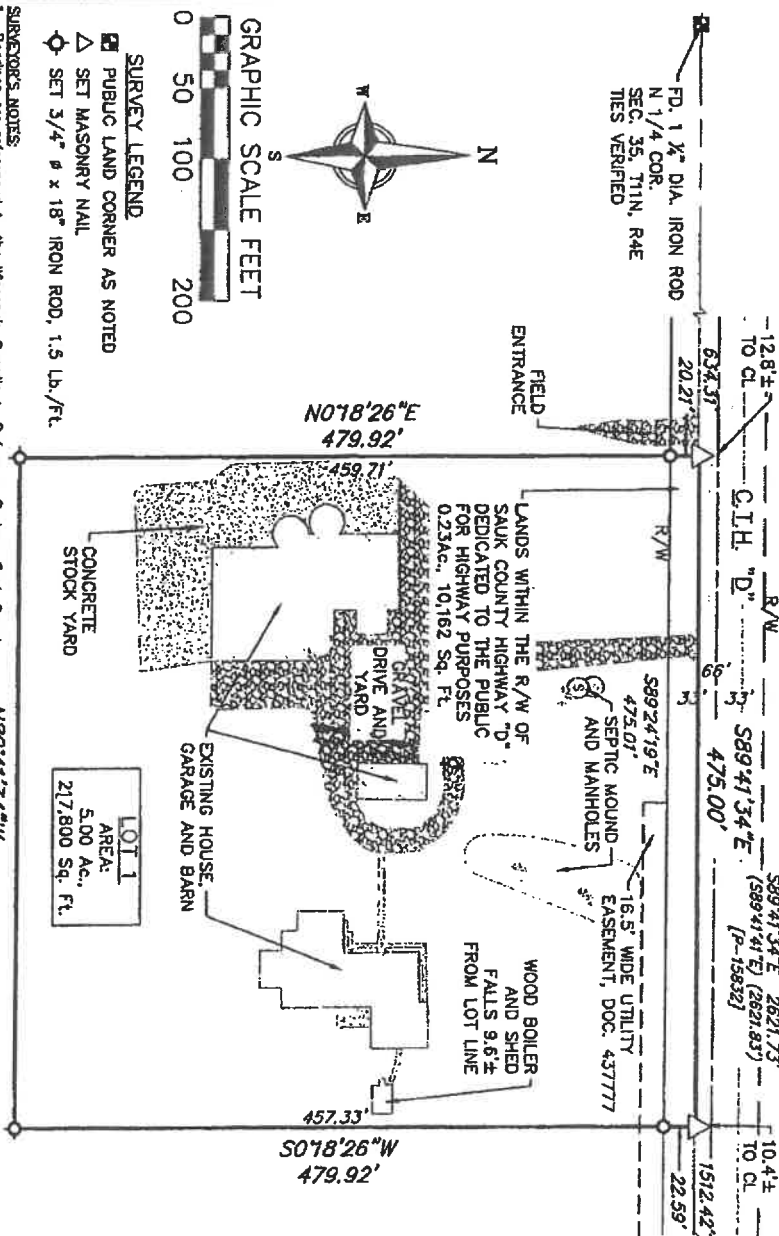

GRAPHIC SCALE FEET
 0 50 100 200

SURVEY LEGEND
 [Symbol] PUBLIC LAND CORNER AS NOTED
 [Symbol] SET MASONRY NAIL
 [Symbol] SET 3/4" # x 18" IRON ROD, 1.5 Lb./Ft.

SURVEYOR'S NOTES:
 1. Bearings are referenced to the Wisconsin Coordinate Reference System, Sauk County, (MAD83/2011), the north line of the northeast quarter of Section 35, T11N, R4E bears S89°41'34"E.
 2. Field work was performed on 11/23/2022.
 3. The Sauk County Department of Land Resources and Environment require that 28 Acres of be placed into a conservation easement. FPO Preservation Area Easement Doc. No. 28 Acres.
 4. Through Wis. Stat. § 823.08, the Wisconsin Legislature has adopted a right to farm law. This statute limits the remedies of owners of later established residential property to seek changes to nearby pre-existing agricultural practices. Active agricultural operations are now taking place and are planned to continue on lands in the vicinity of this CSA. These active

agricultural operations may produce noises, odors, dust, machinery traffic or other conditions during daytime and evening hours.
 5. Lot 1 on this CSA is considered unbuildable until a "soils and site evaluation report" as required by the Department of Safety and Professional Services is filed with the Sauk County Land Resources and Environment Department.
 6. Net area values are exclusive of lands within the right-of-way of Sauk County Highway "D".



TOTAL AREA:
 5.23 Ac.
 227,982 Sq. Ft.

REVISIONS	SCALE	1" = 100'	SHEET
321	CHECKED	sdis	1 OF 2
	DRAFTER	mton	
	FILE	220333.dwg	
JOB NO. 220333	DATE	1/4/2023	

vierbicher
 planners engineers advisors

Da 7257

SAUK COUNTY CERTIFIED SURVEY MAP 72-57
 PART OF THE NW 1/4 - NE 1/4 OF SECTION 35, T11N, R4E, SAUK COUNTY, WISCONSIN

SURVEYOR'S CERTIFICATE:

I, Marc A. Londo, Wisconsin Professional Land Surveyor No. 2696, hereby certify that in full compliance with the provisions of Chapter 236 of the Wisconsin Statutes, Chapter A-E7 of the Wisconsin Administrative Code and the subdivision regulations of the Town of Westfield, and under the direction of Homer D. Beachy, I have surveyed, divided and mapped this Certified Survey; that such map correctly represents all exterior boundaries and the subdivision of the land surveyed; and that this land is located in the Northwest Quarter of the Northeast Quarter of Section 35, T11N, R4E, Town of Westfield, Sauk County, Wisconsin, containing 5.23 acres of land and described as follows:

Part the Northwest Quarter of the Northeast Quarter of Section 35, T11N, R4E, Town of Westfield, Sauk County, Wisconsin and bounded by a line described as follows:

Commencing at the north one-quarter corner of said Section 35, T11N, R4E; Thence S89°41'34"E, along the north line of the said Northeast Quarter of said Section 35, 634.31 feet, to a set masonry nail and the Point of Beginning; (P.O.B.) of this legal description;

Thence S89°41'34"E, continuing along the said north line of the said Northeast Quarter of said Section 35, 475.00 feet, to a set masonry nail; Thence, S00°18'26"W, 479.92 feet, to a set 3/4" diameter iron rod; Thence, N89°41'34"W, 475.00 feet, to a set 3/4" diameter iron rod; Thence, N00°18'26"E, 479.92 feet, returning to the point of beginning;

Certified Survey Map contains 5.23 Ac., 227,962 Sq. Ft., (5.00 Ac., 217,900 Sq. Ft., Excluding the right-of-way of Sauk County Highway "D" and is subject to all other easements and rights of way of record.

Marc A. Londo, WI PLS #2696
 Vierbicher Associates, Inc.
 400 Viking Drive
 Reedsburg, WI 53959
 (608)524-6468
 mlon@vierbicher.com

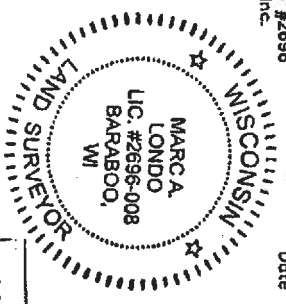

NOTED
 ACTING
 dsca

OWNER'S CERTIFICATE OF DEDICATION
 As owners, we hereby certify that we caused the land described on this plat to be surveyed, divided, mapped and dedicated as represented on this map. We also certify that this plat is required by s.235.10 or s.235.12 to be submitted to the following for approval or objection:
 The Town of Westfield
 The Sauk County Department of Land Resources and Environment

WITNESS the hand and seal of said owners this 12 day of January ~~2022~~ ²⁰²³ in presence of:

Homer D. Beachy Date 1-12-23

Edna Mae Beachy Date 1-12-23

STATE OF WISCONSIN) Midway) MI
 COUNTY SS 05101A

Personally came before me this 12 day of January ~~2022~~ ²⁰²³ the above named Homer D. Beachy and Edna Mae Beachy, to me known to be the same person who executed the foregoing instrument and acknowledged the same.

Anna Marie G. Nofre Public Notary Public, Dodge County Wisconsin
 My commission expires 02-09-2023

SAUK COUNTY DEPARTMENT OF LAND RESOURCES AND ENVIRONMENT
 Resolved, that this Certified Survey Map in the Town of WESTFIELD, Homer D. and Edna Mae Beachy, owners, is hereby approved by the Sauk County Department of Land Resources and Environment.

BR
 Planning Agent Date 1-21-2023

TOWN OF WESTFIELD APPROVAL CERTIFICATE
 Resolved, that this Certified Survey Map in the Town of Westfield, Homer D. and Edna Mae Beachy, owners, is hereby approved by the Town of Westfield Board.

Doug Willemson Date 1-10-2023
 Board Chair

04 Jan 2023 - 9:50am PL Beachy, Homer 220333 - Town of Westfield CAMA 220333 - Westfield CAMA.dwg by: mlon

REVISIONS	SCALE 1" = 100'	SHEET
022	CHECKED sdis	2 OF 2
	DRAFTER mlon	
	FILE 220333.dwg	
JOB NO. 220333	DATE 1/4/2023	



Da 7257.A



Land Resources & Environment
 Department
 505 Broadway, Ste. 248
 Baraboo, Wisconsin 53913
 Phone: (608) 355-3245
 Fax: (608) 355-3292
 www.co.sauk.wi.us

Application Accepted: 10-6-23
 Accepted By: Will C
 Petition Number: 14-23
 Hearing Date: 11-28-23
 Supervisor District #: 25

RECEIVED
 SAUK COUNTY

SEP 18 2023

LAND RESOURCES &
 ENVIRONMENT

Conditional Use Permit Application

General Information

Property Owner Name: <u>Clayton Yoder</u>	Home Phone: <u>608-495-1020</u>
Mailing Address: <u>56911 CR D Loganville, WI 53943</u>	Cell Phone: <u>608-495-1242</u>
E-mail Address:	
Agent/Applicant Name:	Home Phone:
Mailing Address:	Cell Phone:
E-mail Address:	

Site Information

Site Address: 56911 CR D Loganville, WI 53943
 Parcel ID: 040-0727-10000
 Property Description: NW 1/4 NE 1/4 Section 35, T 11 N, R 4 W,
 Town of: Westfield Zoning: EA
 Overlay District: Shoreland Floodplain Airport
 Current Use:
 Existing Structures/Improvements: House, Barn Garage

Proposed Use

Applicable Ordinance Section	Description
<u>7,034 (c)(i)</u>	<u>Kennel (portable)</u>

Describe specifically the nature of the request (be sure to list all proposed uses of the property). What do you plan to do?
 Please attach additional sheets, if necessary.

Refer to letter

CR # 3981-8250⁰²

If your proposal has additional development or secondary standards, please explain how your proposal meets or exceeds those requirements. Please attached additional sheets, if necessary.

General Application Requirements

<p>Applications will not be accepted until the applicant has met with department staff to review the application and determine if all the necessary information has been provided. All information from the checklist must be provided to the Department to be considered a complete application. Only complete applications submitted by the deadline will be noticed for a specific hearing date/time.</p>
<input type="checkbox"/> Completed Conditional Use Permit Application Form.
<input type="checkbox"/> A completed Land Use Permit Application Form with appropriate fee, payable to Sauk County LRE
<input type="checkbox"/> \$500 application fee (non-refundable), payable to Sauk County LRE
<input type="checkbox"/> A written narrative of the proposed conditional use; to include: a description of the proposed business activity; equipment used in the business activity; days/hours of operation; number of employees; noise, dust, vibration, fumes abatement measures; visual screening measures; and other features or characteristics (signs, fences, outdoor display/storage areas, etc.).
<input type="checkbox"/> A scaled site plan which shall include the location of all existing and proposed buildings, driveways, entrances, sidewalks, trails, and signs; the location, size number and screening of all parking spaces.
<input type="checkbox"/> Landscaping Plan, if applicable.
<input type="checkbox"/> Stormwater and Erosion Control Plan, if applicable.
<input type="checkbox"/> A detailed proposal including covenants, agreements, or other documents showing the ownership and method of assuring perpetual maintenance of land to be owned or used for common purposes.
<input type="checkbox"/> Building elevation and floor plans, if applicable.
<input type="checkbox"/> Any other information as required by the zoning administrator to explain the request.

Conditional Use Standards

Part A: Conditional Use Standards

Please explain how the establishment, maintenance, or operation of the proposed use may not be detrimental to or endanger the public health, safety, or general welfare of the occupants of surrounding lands.

Our kennel will strictly involve family members & will not be closer than 1000 ft of neighbors. (in fact closer to 1500 ft). We plan on having a vegetation buffer & trees for natural farm appearance, & possibly a privacy fence if needed. All canines will be confined in a way where there is no detriment to neighbors health, safety or general welfare.

Please explain how the use will be designed constructed, operated, and maintained so as to be compatible and be appropriate in appearance with the existing or intended character of the general vicinity, and that such use may not change the essential character of the area by substantially impairing or diminishing the use, value or enjoyment of existing or future permitted uses in the area.

By using a vegetative buffer and planting trees (and possibly using a privacy fence) and putting in a building just like our other farm buildings, then it will not be incompatible with surrounding landscape and will be appropriate in appearance with surrounding area.

Part B: Conditional Use Criteria

Please explain how the proposed conditional use is able to address the following:

- (a) Erosion potential of the site based on topography, drainage, slope, soil type, and vegetative cover and mitigation of erosion potential.
- (b) The prevention and control of water pollution, including sedimentation, and the potential impacts on floodplain and wetlands.
- (c) Whether the site has adequate utilities including, acceptable disposal systems.
- (d) Whether the site has access to roads and highways.
- (e) Whether the site has suitable ingress and egress.
- (f) Whether the site is designed to minimize traffic congestion, and the potential effect on traffic flow.

We plan on doing slight landscaping to direct drainage around proposed building site and put in gravel + also concrete to set portable building on. There are no adjacent water ways or flood plains that will be affected. Our dwelling house has existing facilities for family business + access is an existing access already off of CR D. There will be very minimum traffic flow as sales are 90% which sales or delivered by me in person

Certification

I certify by my signature that all information presented herein is true and correct to the best of my knowledge. I give permission for the staff of the Sauk County Land Resources & Environment Department to enter my property for the purpose of collecting information to be used as part of the public hearing process. I understand that the conditional use fee is a non-refundable, regardless if the conditional use is approved or denied. I understand that the fee for this application is only for the conditional use request and if permits are required for the project that those will require separate application(s) and/or fee(s). I understand that partial or incomplete applications will be returned to the applicant resulting in the application being removed from the hearing agenda and the submittal deadlines will restart. I further agree to withdraw this application if substantive false or incorrect information has been included.

Applicant/Agent: Clayton Yoder Date: 9-16-23

Property Owner Signature: Clayton Yoder Date: 9-16-23

At the public hearing, the applicant may appear in person or through an agent or an attorney of their choice. The applicant/agent/attorney may present testimony, evidence and arguments in support of the application. All site plans, pictures, etc. become the property of the Land Resources & Environment Department, will remain in the file, and will be public record.

Please Note: If a conditional use application is denied by the LRE Committee and no appeal is filed, no new conditional use application can be re-submitted for a period of 365 days from the date of the LRE Committee's decision, except on grounds of new evidence or proof of changes of factors found valid by the LRE Committee

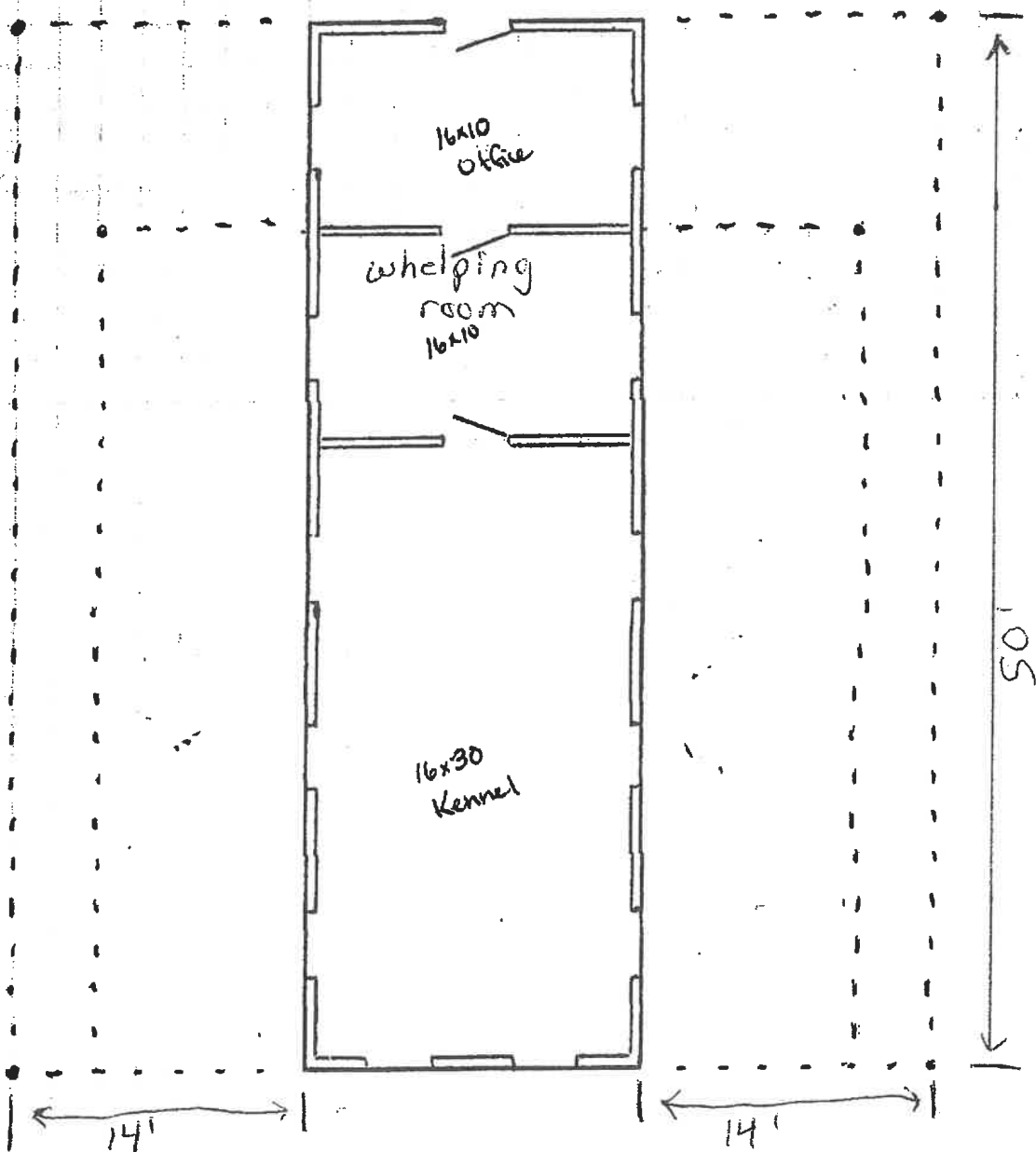



Individual Indoor Kennel spaces

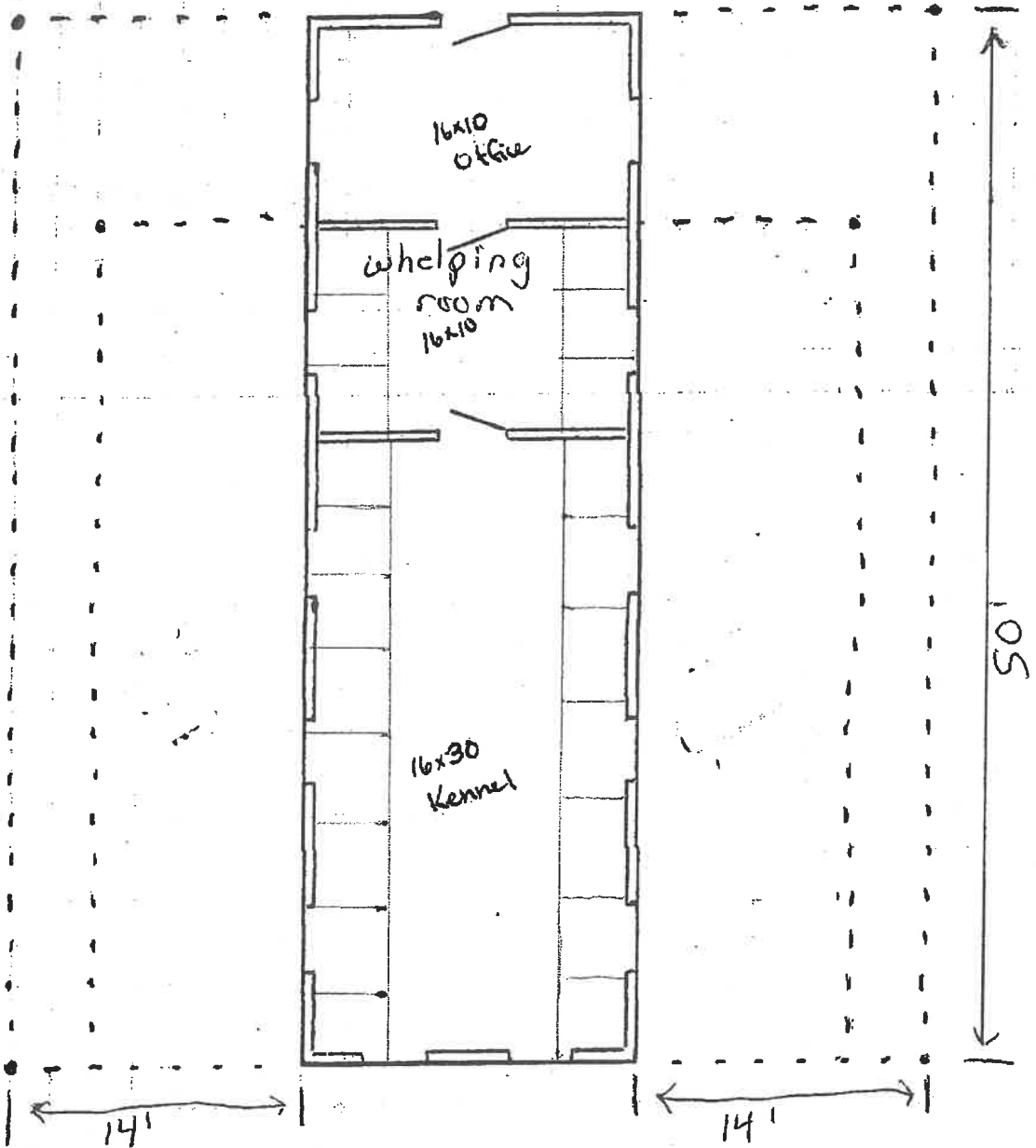



Outside Kennel runs

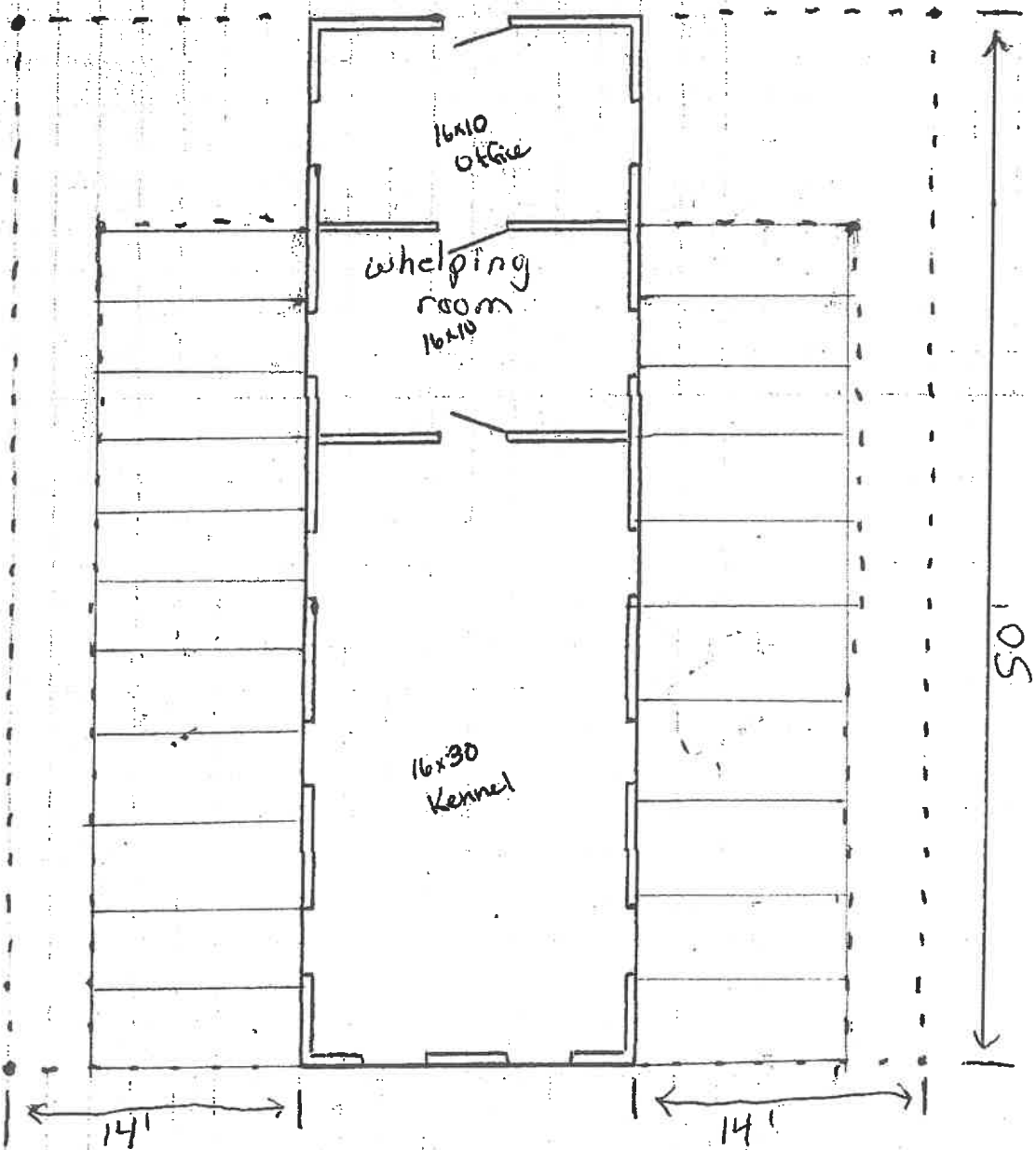



Roof Overhang

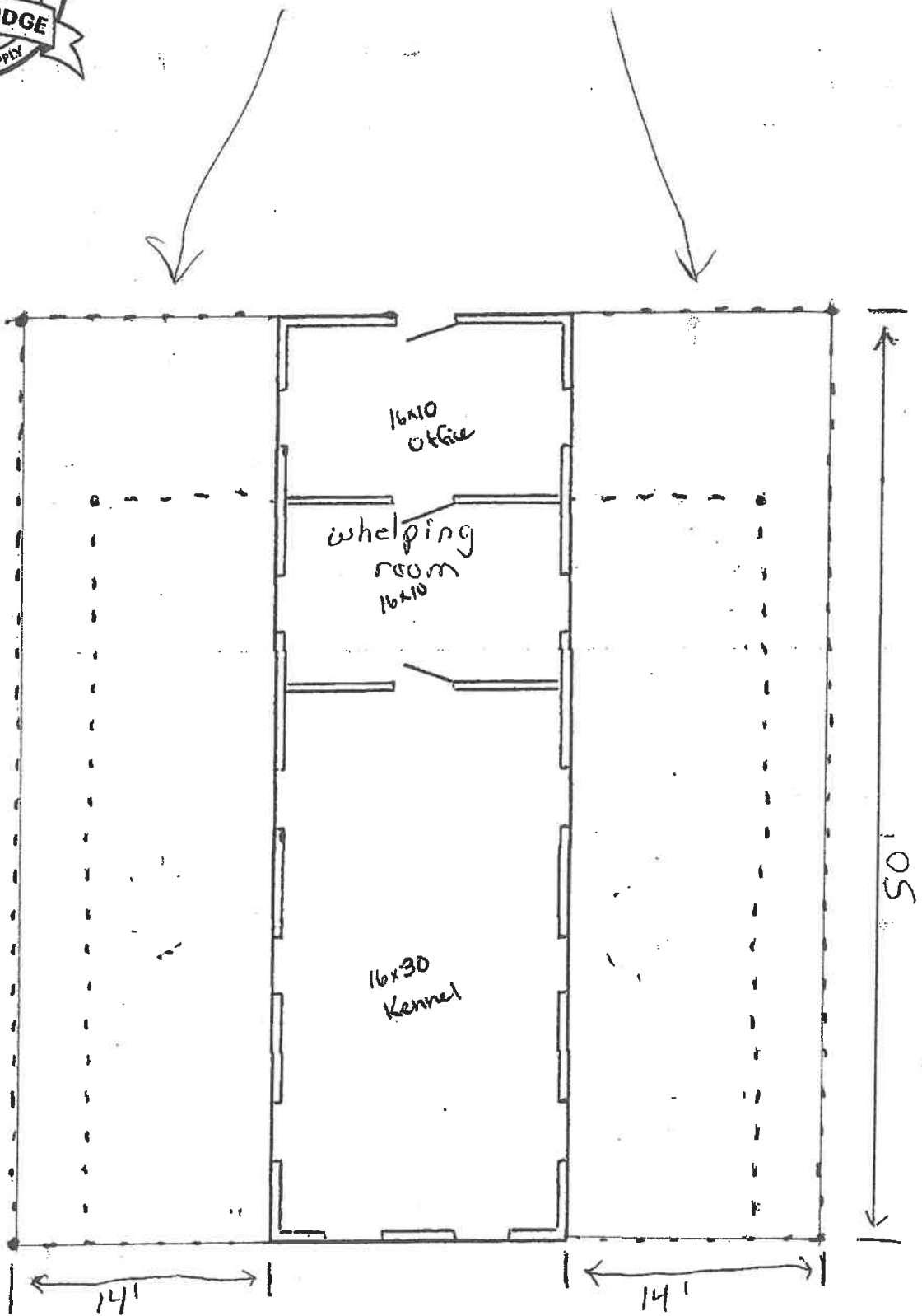

SaukLetterLandscape



Sec 26
T11 R04

0565 SE
SWSE

0566

Dedicated to Public - 0727-00001



00.00, 01 0.02 0.03 mi

FOR INFORMATION

PROCESS ONLY Sauk County does not warrant the accuracy of the data contained herein and makes no warranty with respect to its completeness or validity. Data contained

is limited by the method and accuracy of its collection.

SAUK COUNTY
WISCONSIN

Clayton Joda 10.6.23

Sauk County Land Information/GIS

10/6/2023



Sauk County Land Information/GIS

0 0.001 0.01 0.02 mi

Red dots indicate tree planting



Clayton Jordan 10-6-23

10/6/2023

FOR INFORMATIONAL PURPOSES ONLY: Sauk County does not claim to the accuracy of the data contained therein and makes no warranty with respect to its completeness or validity. Data contained herein is provided by the method and accuracy of its collection.



**Land Resources & Environment
Department**
505 Broadway, Ste. 248
Baraboo, Wisconsin 53913
Phone: (608) 355-3245
Fax: (608) 355-3292
www.co.sauk.wi.us

Application Accepted: 10-16-23
Accepted By: T17
Petition Number: Rez 15-23
Current Zoning: Commercial
Proposed Zoning: Resource Conservancy
Committee Hearing Date: 11-28-23
County Board Date: 12-19-23
Supervisor District #: 27

RECEIVED
SAUK COUNTY

OCT 12 2023

LAND RESOURCES &
ENVIRONMENT

Zoning Map Amendment (Rezoning) Application

General Information

RECEIVED
NOV 02 2023
SAUK COUNTY CLERK
BARABOO, WISCONSIN

Property Owner Name: John Wells Home Phone: 608-477-8884
Mailing Address: 33927 Logans Ln, Baraboo, WI Cell Phone:
E-mail Address: patience_rotondi@yahoo.com
Agent/Applicant Name: Neira custom Homes Home Phone: 608-253-0319
Mailing Address: 613 Broadway, Wisconsin Dells, WI Cell Phone: 608-472-4624
E-mail Address: fiorella@neiraco.com

Site Information

Site Address:
Parcel ID: 002-0633-10000
Property Description: N1/4 NE 1/4 Section 21, T12 N, R6 E,
Town of: Baraboo Current Zoning: Commercial
Overlay District: Shoreland Floodplain Airport
Current Use: Empty lot

Existing Structures/Improvements: none

Proposed Zoning

Proposed Ordinance Section	Proposed Zoning/Use Description
<u>7.015</u>	<u>Resource Conservancy</u>

Describe specifically the nature of the request (be sure to list all proposed uses of the property). What do you plan to do? Please attach additional sheets, if necessary.

We'd like to build a single family home. In order to do so we have been recommended by Sauk County LRE to rezone to Resource Conservancy. as single family residence is not permitted in commercial zoning w/o a business located there first.

CC payment \$500⁰⁰³
P. # 010624

General Application Requirements

Applications will not be accepted until the applicant has met with department staff to review the application and determine if all the necessary information has been provided. All information from the checklist must be provided to the Department to be considered a complete application. Only complete applications submitted by the deadline will be noticed for a specific hearing date/time.

- Completed Zoning Map Amendment Application Form.
- \$500 application fee (non-refundable), payable to Sauk County LRE.
- Town/County Scheduling Form completed by the applicant and Township.
- A scaled map of the proposed rezone area (if the property is not vacant the location of buildings, driveways, etc. must be shown).
- Legal description of the area to be rezoned (CSM, Metes & Bounds description)
- Any other information as required by the zoning administrator to explain the request.

Zoning Map Amendment Standards

Explain how the proposed rezone is consistent with the overall purpose and intent of the zoning ordinance.

The property is currently commercially zoned which does not allow for single family residence. We would like to rezone to Resource Conservancy in order to be permitted to build a single family residence. adjacent parcels are zoned resource conservancy.

If rezoning out of an Exclusive Agriculture Zoning District explain how the land is better suited for a use not allowed in the Exclusive Agriculture Zoning District and how the rezoning will not substantially impair or limit future agricultural use of surrounding parcels of land that are zoned for or legally restricted to agricultural use.

not applicable

Certification

I certify by my signature that all information presented herein is true and correct to the best of my knowledge. I give permission for the staff of the Sauk County Land Resources & Environment Department to enter my property for the purpose of collecting information to be used as part of the public hearing process. I understand that the rezone fee is a non-refundable, regardless if the rezone is approved or denied. I understand that the fee for this application is only for the rezone request and if permits are required for the project that those will require separate application(s) and/or fee(s). I understand that partial or incomplete applications will be returned to the applicant resulting in the application being removed from the hearing agenda and the submittal deadlines will restart. I further agree to withdraw this application if substantive false or incorrect information has been included.

Applicant/Agent: [Signature] Date: 10-11-23
Property Owner Signature: [Signature] Date: 10/11/2023

DocuSigned by: 334
0701821F34E444D...

Zoning Map Amendment Procedures and Requirements

At the public hearing, the applicant may appear in person or through an agent or an attorney of their choice. The applicant/agent/attorney may present testimony, evidence and arguments in support of the application. All site plans, pictures, etc. become the property of the Land Resources & Environment Department, will remain in the file, and will be public record.

What is a Zoning Map Amendment?

The purpose of a zoning map amendment is to alter, enlarge, or reduce a geographic extent of any zoning district; or to enact a new zoning designation for any particular parcel or real property. A change in zoning allows for different land uses and in some instances, different densities of development. The Land Resources & Environment Committee will recommend approval or disapproval of a rezone to the Sauk County Board of Supervisors in accordance with the standards and criteria set by the zoning ordinance.

Standards and Criteria

In reviewing a Zoning Map Amendment request, the LRE Committee must follow four standards:

- a) The proposed map amendment is consistent with the overall purpose and intent of the zoning ordinance.
- b) The proposed map amendment is consistent with the Sauk County Comprehensive Plan and the Farmland Preservation Plan, if applicable.
- c) Factors have changed from the time of initial ordinance adoption that warrant the map change, or an error, inconsistency, or technical problem administering the zoning ordinance as currently depicted has been observed.
- d) In rezoning land out of any exclusive agriculture district, the agency shall find all of the following, after a public hearing:
 1. The land is better suited for a use not allowed in the exclusive agriculture district.
 2. The rezoning is consistent with the Sauk County Comprehensive Plan.
 3. The rezoning is substantially consistent with the Sauk County Farmland Preservation Plan.
 4. The rezoning will not substantially impair or limit current or future agricultural use of surrounding parcels of land that are zoned for or legally restricted to agricultural use.

Note: Pursuant to Wis. Stat § 91.48(1) A political subdivision (Sauk County) with a certified farmland preservation zoning ordinance may not rezone land out of a farmland preservation zoning district (Exclusive Agriculture) without having the rezoning certified under Wis. Stat § 91.36 and provided that the standards (a) through (d) above are met.

Process

1. Contact the LRE Department to schedule a meeting to review your potential request.
2. Complete the Zoning Map Amendment Application and provide all the supplemental items to the LRE Department by the filing deadline.
3. Review such application with the appropriate staff member to determine completeness.
4. If the application is complete, LRE staff will publish notice of your request for a zoning map amendment in the County's official newspaper noting the location and time of the required public hearing before the LRE Committee. Neighbors, town officials, and affected state agencies will be notified as well.
5. If the Town chooses to review the zoning map amendment request at the Town Planning Commission and Town Board level, you will need to attend such meetings to provide information regarding the request. Please request that copies of minutes/proceedings outlining the Town's recommendation be provided to the LRE Department for the file.
6. A public hearing will be held before the LRE Committee. Either the property owner or designated agent will need to be present at the hearing to provide testimony regarding the request. The LRE Committee must make a decision based only on the evidence that is submitted to it at the time of the hearing. Failure to provide representation may result in denial or postponement of your request.
7. The LRE Committee and Sauk County Board of Supervisors may approve, disapprove, or modify and approve the zoning map amendment request.

Please Note: If a zoning map amendment application is not approved by the LRE Committee and no appeal is filed, no new zoning map amendment application can be re-submitted for a period of 365 days from the date of the LRE Committee's decision, except on grounds of new evidence or proof of changes of factors found valid by the LRE Committee.

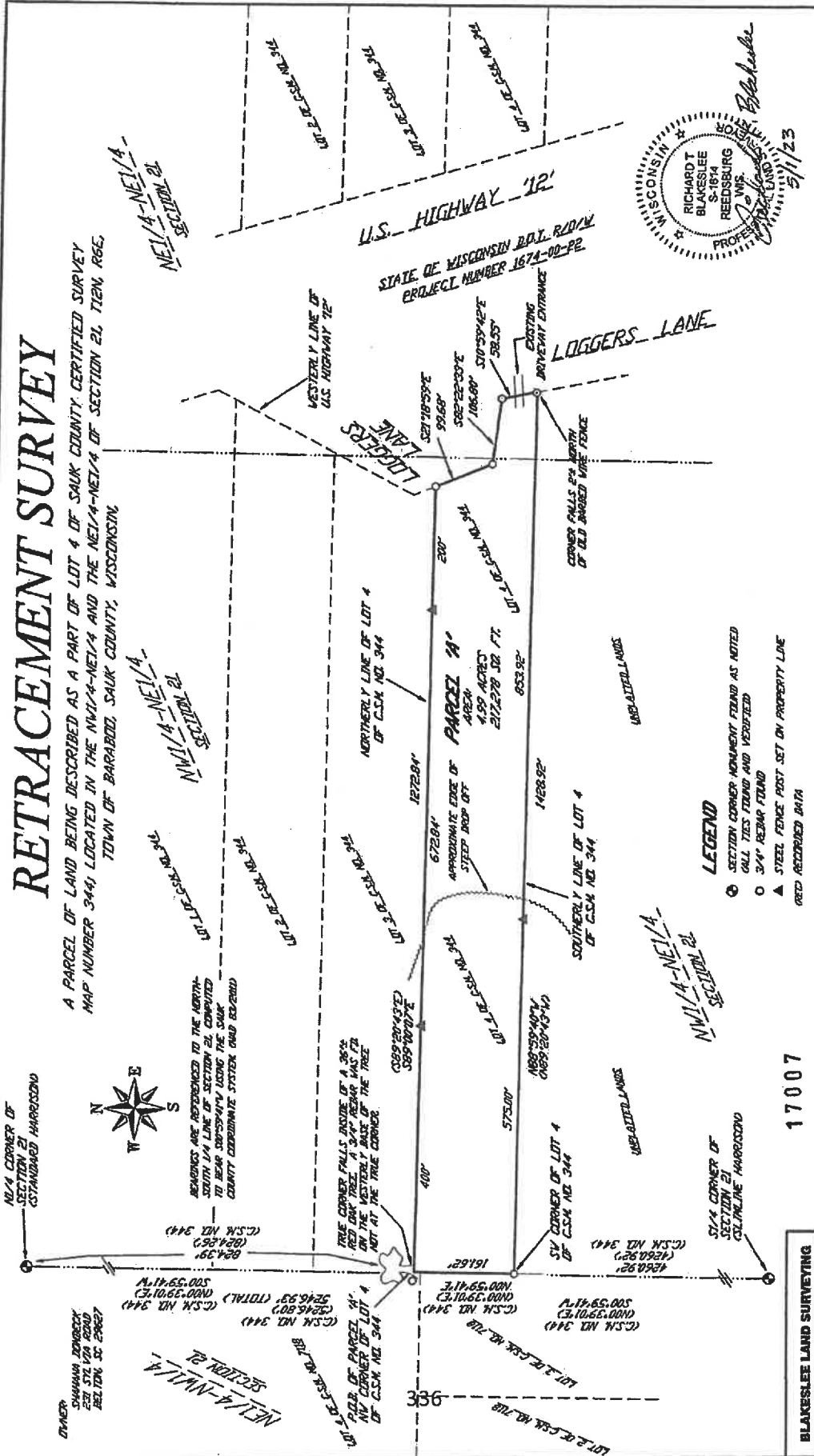

DS

SURVEYOR'S CERTIFICATE
 I, RICHARD T. BLAKESLEE, PROFESSIONAL LAND SURVEYOR, HEREBY CERTIFY THAT I HAVE SURVEYED, DIVIDED, STAKED AND MAPPED THE ABOVE DESCRIBED PARCEL, AND HAVE COMPLIED WITH THE PROVISIONS OF A-E 7 OF THE WISCONSIN ADMINISTRATIVE CODE TO THE BEST OF MY KNOWLEDGE AND BELIEF.

BLAKESLEE LAND SURVEYING
 1228 EAST MAIN STREET
 REEDSBURG, WI 53659
 (608) 824-0402
 FIELD WORK COMPLETED APRIL 28, 2023
 DRAFTED BY J. MURPHY / CHECKED BY R. BLAKESLEE

17007

Legal Description for Parcel 'A'

A parcel of land being described as part of Lot 4 of Sauk County Certified Survey Map Number 344; located in the NW1/4-NE1/4 and the NE1/4-NE1/4 of Section 21, T12N, R6E, Town of Baraboo, Sauk County, Wisconsin; being more fully described as follows:

Commencing at the North ¼ corner of Section 21; thence S00°59'41"W, 824.39 feet long the North-South ¼ line of Section 21 to the Northwest corner of Lot 4 of Sauk County Certified Survey Map Number 344, said point being the point of beginning; thence S89°00'07"E, 1272.84 feet along the Northerly line of the aforesaid Lot 4 to a point on a Westerly line of US Highway '12' as shown on State of Wisconsin D.O.T. R/O/W/ Project Number 1674-00-22; thence S21°18'59"E, 99.68 feet along the aforesaid Westerly line; thence S82°22'33"E, 106.80 feet along a Southerly line of the aforesaid State of Wisconsin D.O.T. R/O/W/ Project Number 1674-00-22; thence S10°59'42"E, 58.55 feet along a Westerly line of the aforesaid State of Wisconsin D.O.T. R/O/W/ Project Number 1674-00-22 to a point on the Southerly line of Lot 4 of Sauk County Certified Survey Map Number 344; thence N88°59'40"W, 1428.92 feet along the aforesaid Southerly line to the Southwest corner thereof; thence N00°59'41"E, 161.62 feet along the Westerly line of the aforesaid Lot 4 to the point of beginning.

Said parcel contains 4.99 acres, more or less, and is subject to all access restrictions and utility easements of record.

17007

SAUK COUNTY LAND RESOURCES & ENVIRONMENT

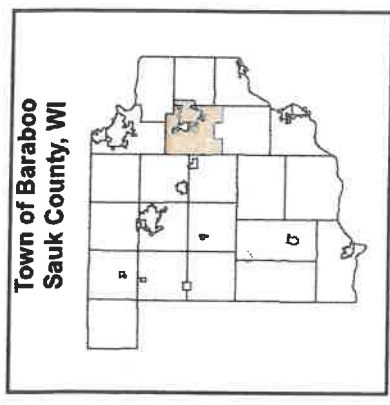

Legend

- Federal
- State Road
- County Road
- Town Road
- Ramp
- Tax Parcel Boundary
- John Wells Property

APPENDIX A



FOR INFORMATIONAL PURPOSES ONLY
 Sauk County does not attest to the
 accuracy of the information shown
 and makes no warranty with respect to
 its correctness or validity. Date contained



1
2
3 **GENERAL CODE OF SAUK COUNTY, WISCONSIN**
4 **ORDINANCE AMENDMENT # 8-2023**
5

6 **Ordinance Amendment to approve a map amendment (rezoning) of lands in the**
7 **Town of Freedom from an Agriculture to a Recreation-Commercial Zoning District**
8 **filed upon Mid-Continent Railway Historical Society, Inc., property owner.**
9

10 **Ordinance Amendment offered by the Land Resources and Environment Committee**

11
12 **BACKGROUND:**

13
14 Background: The Mid-Continent Railway Historical Society, Inc. owns property in the SW
15 ¼, NW ¼, Section 2, T11N, R5E, Town of Freedom, and has requested a map amendment
16 (rezoning) of property legally described pursuant to petition 12-2023 from Agriculture to
17 Recreation-Commercial zoning. The intent of the map amendment (rezoning) is to allow
18 the property owner to use the property in conjunction with and as an accessory to their
19 adjoining property which houses the Mid-Continent Railway Museum.
20

21 Pursuant to Wis. Stat. §59.69(5) Sauk County has the authority to develop, adopt, and
22 amend a zoning ordinance. At a public hearing held by the Land Resources and
23 Environment (LRE) Committee on October 24, 2023; the LRE Committee made findings
24 pursuant to Sauk County Code of Ordinance §7.150(9) and recommended approval of the
25 map amendment.
26

27 Pursuant to Wis. Stat. §66.1001 Wisconsin Statutes, any program or action of a local
28 governmental unit that affects land use shall be consistent with the comprehensive plan.
29 The Sauk County Comprehensive Plan, adopted by the Sauk County Board of Supervisors
30 in 2009, defines managing and focusing "on efficient land use patterns that promotes
31 redevelopment of under-utilized lands. It sets limits on outward growth, incorporates
32 permanent land preservation techniques, and achieves livable communities." Upon
33 evaluation of the request, the Land Resources and Environment Committee found that the
34 rezone request to a Recreation-Commercial Zoning district maintains this objective.
35

36 **NOW, THEREFORE, THE SAUK COUNTY BOARD OF SUPERVISORS DOES**
37 **ORDAIN AS FOLLOWS:**

38 Section 1. Any existing ordinances, codes, resolutions, or portions thereof in
39 conflict with this ordinance shall be and hereby are repealed as far as any conflict exists.

40 Section 2. This ordinance shall take effect the day after passage and publication
41 as required by law.

42 Section 3. If any claims, provisions or portions of this ordinance are adjudged
43 unconstitutional or invalid by a court of competent jurisdiction, the remainder of this
44 ordinance shall not be affected thereby.

45 Section 4. Section 7.005(2) Official Zoning Map of the General Code of Sauk
46 County, Wisconsin, is amended as follows:
47

48 Rezone of the approximate 1.33 acres of tax parcel 016-0026-00000 from an Agriculture
49 Zoning District to a Recreation-Commercial Zoning District.
50

51 Approved for presentation to the County Board by the Land Resources and Environment

52 Committee this ^{14th} ~~24th~~ day of ^{November} ~~October~~, 2023.

53
54 Consent Agenda Item: [] YES [X] NO

55
56 Fiscal Impact: [X] None [] Budgeted Expenditure [] Not Budgeted

57
58 Vote Required: Majority = X 2/3 Majority = _____ 3/4 Majority = _____

59
60 The County Board has the legal authority to adopt: Yes X No _____ as
61 reviewed by the Corporation Counsel, [Signature], Date:
62 11.08.2023

63
64
65 Offered and passage moved by:

66
67 [Signature]
68
69 MARTY KRUEGER, CHAIR

[Signature]
PETER KINSMAN, VICE CHAIR

70
71
72
73 LYNN EBERL

[Signature]
DENNIS POLIVKA

74
75 [Signature]
76
77 BRANDON LOHR

[Signature]
VALERIE MCAULIFFE

78
79 [Signature]
80
81 ROBERT SPENCER

82
83
84
85
86
87
88
89 Fiscal Note: no impact

90
91
92 MIS Note:

RESOLUTION # 88-2023

Resolution to Create new positions for the 2024 Budget

Resolution offered by the Personnel and Insurance Committee

Resolved by the Board of Supervisors of Sauk County, Wisconsin:

BACKGROUND: In accordance with §13.013 of the Personnel Ordinance, "no regular position may be created except by resolution of the County Board." This resolution creates new positions allocated for the 2024 Sauk County budget.

WHEREAS, adoption of this resolution approves the new positions allocated to the 2024 Sauk County budget; and,

WHEREAS, the follow new positions have been reviewed and are recommended for inclusion in the 2024 Sauk County budget in accordance with §13.013 of the Personnel Ordinance.

NOW, THEREFORE, BE IT RESOLVED by the Sauk County Board of Supervisors, met in regular session, that the following positions are created effective January 1, 2024 as part of the 2024 Sauk County budget:

- Building Services – Public Safety Communications Technician, 1.0 FTE
- Building Services – Office Manager, 1.0 FTE (eliminating .50 Program Coordinator BS position)
- Clerk of Courts – Court Interpreter, 1.0 FTE
- Land Resources and Environment – Conservation Technician, 1.0 FTE
- Veteran Services – Veterans Receptionist, .50 FTE

Approved for presentation to the County Board by the Personnel and Insurance Committee, this 14th day of November 2023

Consent Agenda Item: [] YES [X] NO

Fiscal Impact: [] None [X] Budgeted Expenditure [] Not Budgeted

Vote Required: Majority = X 2/3 Majority = 3/4 Majority =

The County Board has the legal authority to adopt: Yes X No as reviewed by the Corporation Counsel, Date: 11-08-2023

52
53

Fiscal / MIS Note: *mk*

	Wages & Benefits	MIS	Other	
Building Services				
Public Safety Communications Technician	\$82,007	\$0	\$0	100% levy
Office Manager	\$97,784	\$0	\$0	100% levy; eliminating .50 FTE Program Coordinator position; department headcount increase of .50 FTE with this addition.
Clerk of Courts				
Court Interpreter	\$86,874	\$0	\$0	2022 state reimbursement \$28,871. 2023 state reimbursement \$14,590.
Land Resources and Environment				
Conservation Technician	\$86,874	\$0	\$0	100% grant
Veterans Services				
Veterans Receptionist	\$26,097	\$0	\$0	100% levy; 1.0 FTE position - .50 FTE with Veterans Services (new), .50 FTE with MIS (current)

54
55
56
57

MIS Note: None

61
62
63
64
65
66
67
68
69
70
71
72
73
74
75
76

Offered and passage moved by:

- _____
Supervisor Carl Gruber Aye Nay Abstain Absent
- _____
Supervisor Terry Spencer Aye Nay Abstain Absent
- _____
Supervisor Peter Kinsman Aye Nay Abstain Absent
- _____
Supervisor Robert Prosser Aye Nay Abstain Absent
- _____
Supervisor Jake Roxen Aye Nay Abstain Absent

RESOLUTION #09-2023

RESOLUTION APPROVING THE 2024 BUDGET AND ESTABLISHING TAXES TO BE LEVIED IN SAUK COUNTY FOR THE YEAR 2023 (PAYABLE IN 2024)

Resolution offered by the Finance Committee

Resolved by the Board of Supervisors of Sauk County, Wisconsin:

BACKGROUND: This resolution adopts the 2023 property tax levy, which is a portion of the 2024 Sauk County Budget.

WHEREAS, adoption of this resolution approves the 2024 proposed County budget and establishes taxes to be levied herein for the taxable year of 2023,

THEREFORE, BE IT RESOLVED, by the Sauk County Board of Supervisors:

- 1. The sum of \$33,694,837.18 be levied as a County General Tax (not including special purpose levies).
2. The sum of \$260.82 be levied as State Special Charges upon the County for Charitable and Penal purposes.
3. The sum of \$30,000 be levied as a Veterans Relief Tax, under Wis. Stat. § 45.86
4. The sum of \$1,303,740.00 be levied upon all towns, and the villages of Cazenovia, Ironton, Lime Ridge, Loganville, Merrimac, and West Baraboo, as a County Library Tax under Wis. Stat. § 43.64
5. The sum of \$95,442 be levied upon all towns, and villages of Cazenovia, Ironton, Lake Delton, LaValle, Lime Ridge, Loganville, Merrimac, Plain, Prairie du Sac, Sauk City, and West Baraboo for a Bridge Tax under Wis. Stat. § 84.18.

Approved for presentation to the County Board by the Finance Committee, this 14th day of November 2023

Consent Agenda Item: [] YES [X] NO

Fiscal Impact: [] None [X] Budgeted Expenditure [] Not Budgeted



Vote Required: Majority = X 2/3 Majority = X 3/4 Majority =

The County Board has the legal authority to adopt: Yes X No as reviewed by the Corporation Counsel, [Signature], Date:

11.08.2023

52
53
54
55
56
57
58
59
60
61
62
63
64
65
66
67
68
69
70
71
72
73

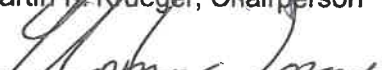
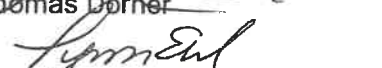
Offered and passage moved by:

 _____	<input checked="" type="checkbox"/> Aye	<input type="checkbox"/> Nay	<input type="checkbox"/> Abstain	<input type="checkbox"/> Absent
Martin F. Krueger, Chairperson				
 _____	<input type="checkbox"/> Aye	<input type="checkbox"/> Nay	<input type="checkbox"/> Abstain	<input type="checkbox"/> Absent
Thomas Dörner				
 _____	<input checked="" type="checkbox"/> Aye	<input type="checkbox"/> Nay	<input type="checkbox"/> Abstain	<input type="checkbox"/> Absent
Lynn Eberl				
 _____	<input checked="" type="checkbox"/> Aye	<input type="checkbox"/> Nay	<input type="checkbox"/> Abstain	<input type="checkbox"/> Absent
Richard "Mike" Flint				
 _____	<input type="checkbox"/> Aye	<input type="checkbox"/> Nay	<input type="checkbox"/> Abstain	<input type="checkbox"/> Absent
Timothy McCumber				

Fiscal Note: Passage of this resolution establishes the 2023 County Levy totaling \$35,124,280.00, which is a portion of the total 2024 County Budget *amb*

MIS Note: Various MIS projects and acquisitions are included in the 2024 budget.

MINUTES

SAUK COUNTY BOARD OF SUPERVISORS

NOVEMBER 29, 2023

WEST SQUARE BUILDING, 505 BROADWAY, ROOM 326, BARABOO, WI

SPECIAL MEETING: SAUK COUNTY BOARD OF SUPERVISORS

1. Call to Order and Certify Compliance with Open Meeting Law: 6:00 P.M.

2. Roll Call. PRESENT: (24) T. Spencer, Eberl, Rego, Kinsman, Klitzke, Scanlon, Anderson, Krueger, Clemens, Lombard, Dorner, Fordham, Astle, Hazard, Carver, Polivka, Burchill, Peper, Lohr, Detter, Stehling, McAuliffe, Deitrich and McCumber. ABSENT & EXCUSED: (7) Roxen, Flint, Prosser, Schell, R. Spencer, Gruber and Chrisler.

Staff present: Brent Miller, County Administrator; Brian Desmond, Corporation Counsel; Becky Evert, Sauk County Clerk.

3. Invocation and Pledge of Allegiance. Invocation given by Supervisor Dorner.

4. Adopt Agenda. MOTION (Klitzke/Carver). Motion carried unanimously.

5. Adopt The Minutes: None.

6. General Consent Agenda Items: None.

7. Scheduled Appearances: None.

8. Public Comment: None.

9. Communications: None.

10. Appointments. None.

11. Bills. None.

12. Claims. None.

13. Elections. None.

14. Proclamations. None.

15. Reports – informational, no action required: None.

16. Unfinished Business. None.

17. New Business.

It is anticipated that the County Board may enter into closed session pursuant to:

a. Wis.Stat. s.19.85(1)(e) Deliberating or negotiating the purchasing of public properties, the investing of public funds, or conducting other specified public business, whenever competitive or bargaining reasons require a closed session; and 19.85(1)(g) Conferring with legal counsel for the governmental body who is rendering oral or written advice concerning strategy to be adopted by the body with respect to litigation in which it is or is likely to become involved. (Topic: 3:22-cv-00562-wmc

Olson, Daniel v. Sauk County et al) *All named defendants represented by Attolles Law, s.c. are allowed in the closed session.*

-and-

b. Pursuant to Wisc. Stats. 19.85(1)(c) Considering employment, promotion compensation or performance evaluation data of any public employee over which the governmental body has jurisdiction or exercises responsibility. Topic: Nursing Home Administrator Employment.

A roll call vote will be taken to go into closed session and return to open session. Upon return to open session there will be an announcement of action taken in closed session, or action may be taken based on the closed session (NOTE: If the announcement of action taken in closed session would compromise the need for the closed session, the action taken will not be announced. Any action taken in closed session may be announced when the need for the closed session has passed).

Supervisor Roxen arrived at 6:05 p.m.

MOTION (Eberl/Polivka) to go into closed session allowing all defendants in the Olson case to remain in the room. **VOTE: AYES: (25) Roxen, T. Spencer, Eberl, Rego, Kinsman, Klitzke, Scanlon, Anderson, Krueger, Clemens, Lombard, Dorner, Fordham, Astle, Hazard, Carver, Polivka, Burchill, Peper, Lohr, Detter, Stehling, McAuliffe, Deitrich and McCumber. NAYES: (0). ABSENT & EXCUSED: (6) Flint, Prosser, Schell, R. Spencer, Gruber and Chrisler. Motion carried unanimously.**

Closed session began at 6:07 p.m.

The meeting resumed in open session at 7:03 p.m.

18. Referrals.

19. **New Agenda items (no discussion). Submit in writing or by e-mail new business items to the County Administrator as soon as possible for Rule III.A. referral.**

20. **Adjournment to a date certain: MOTION (Eberl/T. Spencer) to adjourn at 7:03 p.m.. Motion carried unanimously.**

Respectfully submitted,

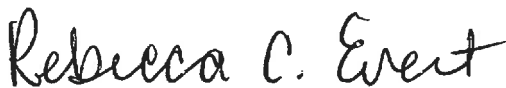

Rebecca C. Evert
Sauk County Clerk

Minutes Approved: December 19, 2023.

State of Wisconsin, County of Sauk: I certify that the above is a true and correct copy of the November 29, 2023 proceedings of the Sauk County Board of Supervisors. /s/Rebecca C. Evert, Sauk County Clerk.

Original documents on file @ Office of the Sauk County Clerk West Square Building, 505 Broadway, Room #144, Baraboo, WI 53913. 608-355-3286.

www.co.sauk.wi.us

These notices may also be found at: <http://www.wisconsinpublicnotices.org/> or <https://www.co.sauk.wi.us/legalnotices>.

MINUTES

SAUK COUNTY BOARD OF SUPERVISORS

DECEMBER 19, 2023

WEST SQUARE BUILDING, 505 BROADWAY, ROOM 326, BARABOO, WI

REGULAR MEETING: SAUK COUNTY BOARD OF SUPERVISORS

1. Call to Order and Certify Compliance with Open Meeting Law: 6:00 P.M.

2. Roll Call. PRESENT: (30) T. Spencer, Eberl, Rego, Kinsman, Klitzke, Scanlon, Anderson, Krueger, Flint, Clemens, Prosser, Lombard, Schell, Dorner, Fordham, Astle, Hazard, R. Spencer, Carver, Polivka, Burchill, Peper, Lohr, Gruber, Detter, Chrisler, Stehling, McAuliffe, Deitrich and McCumber. ABSENT & EXCUSED: (1) Roxen.

Staff present: Brent Miller, County Administrator; Brian Desmond, Corporation Counsel; Becky Evert, Sauk County Clerk; Cora McDonnell, Deputy County Clerk; and Michelle Commings, Deputy County Clerk.

3. Invocation and Pledge of Allegiance. Invocation given by Supr. McCumber

4. Adopt the Agenda. MOTION (Gruber/Schell) to adopt the agenda from the previous meeting.
Motion carried **unanimously**. (*Verbal Vote*)

5. Adopt the Minutes. MOTION (Scanlon/Rego) to adopt the minutes from the previous meetings.
Motion carried **unanimously**. (*Verbal Vote*)

6. General Consent Agenda Items. None.

7. Scheduled Appearances.

a. Dale Knapp, Forward Analytics; re: Senior Healthcare.

8. Public Comment.

a. Ryan Shear, re: SCHCC

b. Jerry Helmer, re: County Nursing Home

c. Jeff Seering, re: SCHCC

9. Communications.

a. 11/20/2023 Letter from Jim Severance, re: Sauk County Health Care Center.

b. 11/29/2023 Letter from Dave Corning, re: Sauk County Health Care Center.

c. Letter from State of Wisconsin DNR, re: Air Pollution Control Permit Application Review.

d. 12/11/2023 Email from Susan Heck, re: Open Meeting Excellence Award.

10. Appointments.

a. Families Come First/Comprehensive Community Services Committee:

i. Billy Laird, New Appointment, Citizen Member

2-year term – 12/19/2023-12/16/2025

ii. John Olsen, New Appointment, Citizen Member

2-year term – 12/19/2023-12/16/2025

b. Sauk County Library Board:

Mike Anderson, District #9 Supervisor, Alternate

Term: 12/19/2023-04/16/2024 (Concurrent with Board of Supervisors)

c. South Central Library Board:

Mike Anderson, District #9 Supervisor

Term: 12/19/2023-04/16/2024 (Concurrent with Board of Supervisors)

d. Land, Resources, and Environment:

Randall Puttkamer, Re-Appointment, Citizen Member

2-year term – 12/19/2023-12/31/2025

e. Veterans Service Commission:

Mike Sitton, New Appointment, Citizen Member

2-year term – 12/19/2023-12/31/2025

MOTION (Klitzke/Polivka) to approve the appointments. Motion carried **unanimously**. (*Verbal Vote*)

11. **Bills.** None.

12. **Claims.** None.

13. **Elections.** None.

14. **Proclamations.** None.

15. **Reports – informational, no action required.**

a. Rebecca C. Evert, Sauk County Clerk – Rezoning petitions filed with the office of the Sauk County Clerk as a requirement of Wisconsin State Statutes 59.69(5)(e): none.

b. Brent Miller

i. Administrator's report.

c. Tim McCumber, County Board Chair

i. Board Chair Update.

16. **Unfinished Business.**

EXECUTIVE & LEGISLATIVE COMMITTEE:

Resolution 77 - 2023 To Amend The Rules Of The County Board.

MOTION (Gruber/Anderson). **VOTE:** AYES: (26) T. Spencer, Eberl, Kinsman, Scanlon, Anderson, Krueger, Flint, Clemens, Prosser, Schell, Dorner, Fordham, Astle, Hazard, R. Spencer, Carver, Polivka, Peper, Lohr, Gruber, Detter, Chrisler, Stehling, McAuliffe, Deitrich and McCumber. NAYS: (4) Rego, Klitzke, Lombard, and Burchill. ABSENT & EXCUSED: (1) Roxen. Motion carried.

17. **New Business.**

AGING & DISABILITY RESOURCE GOVERNING COMMITTEE, FINANCE COMMITTEE, AND PERSONNEL & INSURANCE COMMITTEE:

Resolution 90 - 2023 Resolution To Accept Additional Funding From The Department Of Health For The Independent Living Supports Program And To Use The Funding To Increase An 80% Information & Assistance (I & A) To Full Time Equivalent (FTE) And Amend The 2024 Budget.

MOTION (Polivka/Spencer). **VOTE:** AYES: (30) T. Spencer, Eberl, Rego, Kinsman, Klitzke, Scanlon, Anderson, Krueger, Flint, Clemens, Prosser, Lombard, Schell, Dorner, Fordham, Astle, Hazard, R. Spencer, Carver, Polivka, Burchill, Peper, Lohr, Gruber, Detter, Chrisler, Stehling, McAuliffe, Deitrich and McCumber. NAYS: (0). ABSENT & EXCUSED: (1) Roxen. Motion carried **unanimously**.

EXECUTIVE & LEGISLATIVE COMMITTEE:

Resolution 91 - 2023 Accepting A Hazard Mitigation Grant, Authorizing A Contract With Civi Tek Consulting, LLC For Hazard Mitigation Plan Updates, Included In The 2024 Budget.

MOTION (Gruber/Hazard). VOTE: AYES: (30) T. Spencer, Eberl, Rego, Kinsman, Klitzke, Scanlon, Anderson, Krueger, Flint, Clemens, Prosser, Lombard, Schell, Dorner, Fordham, Astle, Hazard, R. Spencer, Carver, Polivka, Burchill, Peper, Lohr, Gruber, Detter, Chrisler, Stehling, McAuliffe, Deitrich and McCumber. NAYS: (0). ABSENT & EXCUSED: (1) Roxen. Motion carried **unanimously**.

FINANCE COMMITTEE, EXECUTIVE & LEGISLATIVE COMMITTEE AND THE SAUK COUNTY BOARD OF HEALTH:

Resolution 92 - 2023 Authorizing The Purchase Of A Replacement Electronic Health Records System For The Health Department And Amending the 2024 Budget.

MOTION (Rego/Dorner). VOTE: AYES: (30) T. Spencer, Eberl, Rego, Kinsman, Klitzke, Scanlon, Anderson, Krueger, Flint, Clemens, Prosser, Lombard, Schell, Dorner, Fordham, Astle, Hazard, R. Spencer, Carver, Polivka, Burchill, Peper, Lohr, Gruber, Detter, Chrisler, Stehling, McAuliffe, Deitrich and McCumber. NAYS: (0). ABSENT & EXCUSED: (1) Roxen. Motion carried **unanimously**.

LAND RESOURCES & ENVIRONMENT COMMITTEE:

Ordinance 9 - 2023 To Approve A Map Amendment (Rezoning) Of Lands In The Town Of Ironton From An Agriculture To An Exclusive Agriculture Zoning District Filed Upon Gerald And Linda White, Property Owners.

MOTION (Krueger/Dorner). VOTE: AYES: (30) T. Spencer, Eberl, Rego, Kinsman, Klitzke, Scanlon, Anderson, Krueger, Flint, Clemens, Prosser, Lombard, Schell, Dorner, Fordham, Astle, Hazard, R. Spencer, Carver, Polivka, Burchill, Peper, Lohr, Gruber, Detter, Chrisler, Stehling, McAuliffe, Deitrich and McCumber. NAYS: (0). ABSENT & EXCUSED: (1) Roxen. Motion carried **unanimously**.
Ordinance effective upon passage pursuant to 59.69(5)(e)(6), of Wisconsin State Statutes (December 19, 2023).

Ordinance 10 - 2023 To Approve A Map Amendment (Rezoning) Of Lands In The Town Of Baraboo From A Commercial To A Resource Conservancy Zoning District Filed Upon John Wells, Property Owner.

MOTION (Kinsman/Polivka). VOTE: AYES: (30) T. Spencer, Eberl, Rego, Kinsman, Klitzke, Scanlon, Anderson, Krueger, Flint, Clemens, Prosser, Lombard, Schell, Dorner, Fordham, Astle, Hazard, R. Spencer, Carver, Polivka, Burchill, Peper, Lohr, Gruber, Detter, Chrisler, Stehling, McAuliffe, Deitrich and McCumber. NAYS: (0). ABSENT & EXCUSED: (1) Roxen. Motion carried **unanimously**.
Ordinance effective upon passage pursuant to 59.69(5)(e)(6), of Wisconsin State Statutes (December 19, 2023).

Ordinance 11 - 2023 To Approve A Map Amendment (Rezoning) Of Lands In The Town Of La Valle From An Agriculture To A Commercial Zoning District Filed Upon Jay's Holdings LLC, Property Owner.

MOTION (Kinsman/R. Spencer). VOTE: AYES: (29) T. Spencer, Eberl, Rego, Kinsman, Klitzke, Scanlon, Anderson, Krueger, Flint, Clemens, Prosser, Schell, Dorner, Fordham, Astle, Hazard, R. Spencer, Carver, Polivka, Burchill, Peper, Lohr, Gruber, Detter, Chrisler, Stehling, McAuliffe, Deitrich and McCumber. NAYS: (1) Lombard. ABSENT & EXCUSED: (1) Roxen. Motion carried.
Ordinance effective upon passage pursuant to 59.69(5)(e)(6), of Wisconsin State Statutes (December 19, 2023).

Resolution 93 - 2023 To Deny A Proposed Rezone Petition 14-2023.

MOTION (Krueger/Polivka). VOTE: AYES: (30) T. Spencer, Eberl, Rego, Kinsman, Klitzke, Scanlon, Anderson, Krueger, Flint, Clemens, Prosser, Lombard, Schell, Dorner, Fordham, Astle, Hazard, R. Spencer, Carver, Polivka, Burchill, Peper, Lohr, Gruber, Detter, Chrisler, Stehling, McAuliffe, Deitrich and McCumber. NAYS: (0). ABSENT & EXCUSED: (1) Roxen. Motion carried **unanimously**.

Resolution 94 - 2023 Authorizing The County Administrator To Submit Multi-Discharger Variance Application To The Wisconsin Department Of Natural Resources.

MOTION (Kinsman/Polivka). VOTE: AYES: (30) T. Spencer, Eberl, Rego, Kinsman, Klitzke, Scanlon, Anderson, Krueger, Flint, Clemens, Prosser, Lombard, Schell, Dorner, Fordham, Astle, Hazard, R. Spencer, Carver, Polivka, Burchill, Peper, Lohr, Gruber, Detter, Chrisler, Stehling, McAuliffe, Deitrich and McCumber. NAYS: (0). ABSENT & EXCUSED: (1) Roxen. Motion carried **unanimously**.

Resolution 95 - 2023 Authorize Continued County Participation In The Wildlife Damage Abatement Program And The Wildlife Damage Claim Program.

MOTION (Polivka/Kinsman). VOTE: AYES: (30) T. Spencer, Eberl, Rego, Kinsman, Klitzke, Scanlon, Anderson, Krueger, Flint, Clemens, Prosser, Lombard, Schell, Dorner, Fordham, Astle, Hazard, R. Spencer, Carver, Polivka, Burchill, Peper, Lohr, Gruber, Detter, Chrisler, Stehling, McAuliffe, Deitrich and McCumber. NAYS: (0). ABSENT & EXCUSED: (1) Roxen. Motion carried **unanimously**.

PROPERTY COMMITTEE AND FINANCE COMMITTEE:

Resolution 96 - 2023 Authorizing To Contract With Telcom Construction, LLC For The Relocation Of Sauk County Owned Fiber Optic Cable At The Intersection Of CTH BD And N. Reedsburg Rd.; And Amend The 2023 Building Services Capital Outlay Budget.

MOTION (Gruber/Detter). VOTE: AYES: (30) T. Spencer, Eberl, Rego, Kinsman, Klitzke, Scanlon, Anderson, Krueger, Flint, Clemens, Prosser, Lombard, Schell, Dorner, Fordham, Astle, Hazard, R. Spencer, Carver, Polivka, Burchill, Peper, Lohr, Gruber, Detter, Chrisler, Stehling, McAuliffe, Deitrich and McCumber. NAYS: (0). ABSENT & EXCUSED: (1) Roxen. Motion carried **unanimously**.

PERSONNEL & INSURANCE COMMITTEE:

Resolution 97 - 2023 Approve The Liability, Property, And Workers Compensation Coverage, Insurance, Carrier, And Premiums For 2024.

MOTION (Gruber/Kinsman). VOTE: AYES: (30) T. Spencer, Eberl, Rego, Kinsman, Klitzke, Scanlon, Anderson, Krueger, Flint, Clemens, Prosser, Lombard, Schell, Dorner, Fordham, Astle, Hazard, R. Spencer, Carver, Polivka, Burchill, Peper, Lohr, Gruber, Detter, Chrisler, Stehling, McAuliffe, Deitrich and McCumber. NAYS: (0). ABSENT & EXCUSED: (1) Roxen. Motion carried **unanimously**.

PROPERTY COMMITTEE:

Resolution 98 - 2023 To Expand The Long-Term Care Continuum In Sauk County.

MOTION (Detter/Gruber).

MOTION (Krueger/Rego) To Postpone To March 2024 Regular Meeting.

VOTE: AYES: (9) Rego, Krueger, Flint, Fordham, Hazard, R. Spencer, Polivka, Stehling, and McAuliffe.

NAYS: (20) T. Spencer, Eberl, Kinsman, Klitzke, Scanlon, Anderson, Clemens, Prosser, Lombard, Schell, Dorner, Astle, Carver, Burchill, Peper, Lohr, Gruber, Detter, Chrisler and Deitrich.

ABSTAIN: (1) McCumber. ABSENT & EXCUSED: (1) Roxen. Motion failed.

VOTE ON ORIGINAL MOTION (Detter/Gruber)

To Adopt Resolution 98-2023, To Expand The Long-Term Care Continuum In Sauk County.

VOTE: AYES: (22) T. Spencer, Eberl, Kinsman, Klitzke, Scanlon, Deitrich, Anderson, Clemens, Prosser, Lombard, Schell, Dorner, Astle, R. Spencer, Carver, Burchill, Peper, Lohr, Gruber, Detter, Chrisler, and McCumber. NAYS: (7) Rego, Krueger, Flint, Fordham, Hazard, Stehling, and McAuliffe. ABSTAIN: (1) Polivka. ABSENT & EXCUSED: (1) Roxen. Motion carried.

18. Referrals.

19. New Agenda items (no discussion). Submit in writing or by e-mail new business items to the County Administrator as soon as possible for Rule III.A. referral.

20. Adjournment to a date certain: 7:55 P.M. MOTION (Klitzke/Schell) to adjourn until Tuesday, January 16, 2024, at 6:00 P.M. Motion carried unanimously. (Verbal Vote)

Respectfully submitted,

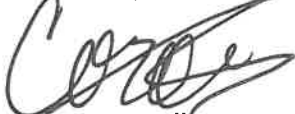

Cora McDonnell
Deputy County Clerk

Minutes Approved: January 16, 2024.

State of Wisconsin, County of Sauk: I certify that the above is a true and correct copy of the December 19, 2023. Proceedings of the Sauk County Board of Supervisors.
/s/Rebecca C. Evert, Sauk County Clerk.

Original documents on file @ Office of the Sauk County Clerk West Square Building, 505 Broadway, Room #144, Baraboo, WI 53913. 608-355-3286.

www.co.sauk.wi.us

These notices may also be found at: <http://www.wisconsinpublicnotices.org/> or <https://www.co.sauk.wi.us/legalnotices>.

RESOLUTION # **77-2023**

Resolution to Amend the Rules of the County Board

Resolution offered by the Executive & Legislative Committee

Resolved by the Board of Supervisors of Sauk County, Wisconsin:

BACKGROUND: Resolution #96-2023 created the Committee on the Consolidation of Committees (hereinafter "CCC"). The CCC was charged "with the duty to review the current Sauk County Committee structure and make recommendations to the full County Board regarding consolidation of standing committees".

The CCC held a series of meetings to discuss the pros and cons of consolidating committees, the financial implications of consolidation, the likelihood of garnering more candidates for Supervisor, the efficiency for staff and the role of the County Administrator in the Sauk County government structure. Based on those discussion and considerations, the CCC developed the new structure for the Sauk County Standing committees as set forth below.

THEREFORE, BE IT RESOLVED, that the Sauk County Standing Committees shall be as set forth below and incorporated into the Sauk County Rules of the Board.

RULE IX. STANDING COMMITTEES OF THE BOARD.

AGING & DISABILITY RESOURCE CENTER COMMITTEE

Responsible for providing services to the general public with respect to matters related to aging and disability and to improve the life of those with aging and disability related issues. This committee will serve as the official statutory Commission on Aging pursuant to Wis. Stat. § 46.82(4) and shall be advised by the Aging, and Disability Advisory Committee. Responsible for policy direction and oversight for the following departments: Aging and Disability Resource Center. See, Sauk Co. Code Ch. 16. Oversight Committee for the Healthcare Center Board of Trustee.

Members: 11. The Committee shall have 6 County Board Supervisors.

ECONOMIC DEVELOPMENT COMMITTEE

Responsible for coordination of County economic development initiatives with County Planners and Sauk County Development Corporation. Involved in strategic resource planning initiatives. Reviews matters which affect growth and development of Sauk County, and economic development of communications network. Responsible for economic development in Sauk County and oversees County coordinated transportation, including overseeing the Tri-County Airport Commission, municipal airports, Pink Lady Rail Transit Commission and Wisconsin River Rail Transit Commission. Responsible for the study, review and recommendation regarding freight, passenger and commuter rail development, intercity and commuter bus services and development, and the provision and coordination of rural and commuter transit services. Transit is governed by Wis. Stat. s. 59.58. Also responsible for oversight regarding arts, humanities, culture and historic preservation projects on behalf of the Board. Serves as the Landmarks Commission in compliance with Sauk Co. Code Ch. 38 and Wis. Stats. §§ 59.56 and 59.69(4m). **Members: 7.**

51 **EXECUTIVE & LEGISLATIVE COMMITTEE**

52 Responsible for proposing amendments and monitoring the operation of Rules of
53 the Board; responsible for the conduct of all intergovernmental relations and
54 affairs; monitors State legislative and administrative activity affecting Sauk County;
55 proposes legislation or action on pending legislation affecting Sauk County;
56 considers matters not specifically assigned to other committees. Responsible for
57 policy direction and oversight to the following departments: County Administrator,
58 Corporation Counsel, County Clerk, Emergency Management. This committee
59 shall also have oversight of the Veteran Services Office.

60
61 Comprised of members from: **The Executive & Legislative Committee shall be**
62 **composed of the Chair and Vice-Chair of the Board, along with the Chair of**
63 **the other Standing Committees. The Chair of the Committee shall vote only**
64 **in the case of a tie.** The County Clerk shall serve as secretary to this committee.
65 The County Administrator, Corporation Counsel, and County Clerk shall serve as
66 *ex officio* members of this committee without voting privileges. **Members: 9.**

67
68 **FINANCE, PERSONNEL & INSURANCE COMMITTEE**

69 Responsible for financial policy initiation and review of all County fiscal matters,
70 including reviewing and possibly revising the annual County operating budget,
71 submitted to the Committee by the County Administrator, for presentation to the
72 Board. Reviews County investment and banking policies; manages County
73 general fund and contingency fund; reviews per diem and mileage for all
74 committees, commissions, boards or councils; recommends approval of County
75 audit report; receives all special gifts and grants made in favor of the County.
76 Responsible for policy jurisdiction over all County personnel matters including:
77 recruitment and selection; collective bargaining and contract administration;
78 employee relations; salary administration for all appointed and elected personnel;
79 classification systems; employee training; fringe benefits; and reviews all new
80 position requests and vacant positions. Oversees the County's safety program and
81 safety training. Provides for all property, liability, and worker's compensation
82 insurance needs for the County. Provides policy direction and oversight to
83 Accounting, County Treasurer, the Personnel Department and Risk/Safety
84 Manager. **Members: 9.**

85
86 **HEALTH RESOURCES**

87 Responsible for policy direction and oversight of Health Department pursuant to
88 Wis. Stat. Chs. 250 through 255 relating to public and environmental health
89 matters. See, Sauk Co. Code Ch. 3. Responsible for policy direction and oversight
90 for Human Services Department pursuant to Wis. Stat. chs. 46 and 51 and Wis.
91 Stat. § 59.53 to oversee social services and community programs. **Members: 9;**
92 **5 Supervisors, 1 M.D., 1 R.N., One member that represents the diversity of**
93 **the county, 1 member who receives, or has a family member that receives,**
94 **services from the Department of Human Services.**

95
96 **LAND RESOURCES & ENVIRONMENT COMMITTEE**

97 Responsible for policy direction for County planning, land use regulations,
98 surveying, remonumentation, mapping and uniform rural building identification
99 system, land records modernization activities. Serves as the County Zoning
100 Agency pursuant to Wis. Stat. § 59.69. Establishes policies relating to planning,
101 acquisition, development and maintenance of County owned park and recreation

102 sites. Responsible for natural resource management, resource conservation and
103 environmental protection including soils, water, forestry and wildlife resources
104 through participation in various federal, state and local programs. Responsible for
105 developing sustainable practices within County operations and serving in an
106 advisory capacity regarding "green technologies." Responsible for the
107 development and implementation of the Sauk County Outdoor Recreation Plan.
108 Responsible for review and approval of vouchers related to the Sauk County
109 Outdoor Recreation Plan. Oversees operation of farmland located at the original
110 Sauk County Health Care Center. Serves as the Farmland Preservation Review
111 Committee. Also, jointly responsible with the Area Extension Director for oversight
112 of University of Wisconsin-Madison, Division of Extension educational
113 programming in agriculture and natural resources, community and economic
114 development, family living, 4-H and positive youth development, horticulture, and
115 County tourism and promotion activities on behalf of the Board.
116

117 **Members: 9; 7 Supervisors, 6 of whom shall be Supervisors from districts**
118 **that have at least a portion of their district in County Zoning, 1 Citizen who**
119 **meets the requirements of Wis. Stat. § 92.06(1)(b)(2), 1 citizen may be**
120 **appointed who shall be a public school administrator in the County. If there**
121 **is no school administrator appointed then a Supervisor shall be appointed**
122 **to fill that spot on the committee.** Pursuant to Wis. Stat. § 92.06(1)(b)(2) the
123 designee shall be a person who is engaged in agricultural use, as defined under
124 s. 91.01 (2)(a)1, and shall be a member of the Committee but shall refrain from
125 discussion and voting on any matter where the Committee is acting as the County
126 Zoning Agency. A public school administrator, if one is appointed, shall be a
127 Member of the Committee but shall refrain from voting on matter not related to UW-
128 Extension. Members of this committee shall serve on the lake protection districts.
129 Provides policy direction and oversight to the following departments: Land
130 Resources and Environment; Parks; County Surveyor; Land Information Officer;
131 Register of Deeds; and Mapping.
132

133 **LAW ENFORCEMENT & JUDICIARY COMMITTEE**

134 Responsible for exploration of justice alternatives. Provides policy direction and
135 oversight on behalf of the Board to the following departments: District Attorney,
136 Coroner, Clerk of Courts, Court Commissioner, Register in Probate, Child Support,
137 and Circuit Court Judges, Sheriff, and the Animal Shelter. **Members: 9.**
138
139

140 **PUBLIC WORKS AND INFRASTRUCTURE COMMITTEE**

141 Responsible for policy direction in design, construction and maintenance of all
142 County roads and expenditure of highway maintenance funds received from the
143 state or County, including planning, development of, and maintenance of all
144 structures required for storage, maintenance and operations relating to the
145 Highway Department. Pursuant to Wis. Stat. § 83.015(1)(c), this Committee is
146 designated the County Highway Committee and each member is appointed and
147 vacancies filled pursuant to the procedures contained in these Rules. Responsible
148 for policy direction and oversight for Highway Department. Responsible for
149 providing policy direction with regard to matters involving County property. Handles
150 all matters relating to the acquisition of real property, construction, building
151 improvements, repair or maintenance not specifically delegated to other
152 committees. Responsible for planning and implementation of space use in County

153
154
155
156
157
158
159
160
161
162
163
164
165
166
167
168
169
170
171
172
173
174
175
176
177
178
179
180
181
182
183
184
185
186
187
188
189
190
191
192
193
194
195
196
197
198
199
200
201
202
203

buildings. Oversees the appraisal and sale of tax delinquent County property by the County Treasurer and reviews the disposition of, or the granting of easements on, County real property. Responsible for the physical management requirements associated with the closed Sauk County Landfill. Approves the use of County owned property by non-County groups when such property is not under the direct purview of another committee. Oversees communications infrastructure, including fiber optic cable, towers, and associated equipment. Responsible for the overall information technology requirements for all departments and agencies of Sauk County. Responsible for oversight of the Management Information Systems department. Provides overall planning and long-range forecasting for the information systems needs of Sauk County. Provides oversight to the Building Services Department **Members: 9.** [Drafter's Note: Elimination of the Communications & Infrastructure Committee and transfer of its functions to the Property Committee was approved on April 29, 2019 but is not effective until April 21, 2020]

Approved for presentation to the County Board by the Executive & Legislative Committee, this _____ day of December, 2023

Consent Agenda Item: [] YES [x] NO

Fiscal Impact: [X] None [] Budgeted Expenditure [] Not Budgeted

Vote Required: Majority = _____ 2/3 Majority = X 3/4 Majority = _____

The County Board has the legal authority to adopt: Yes X No _____ as reviewed by the Corporation Counsel, [Signature], Date: 12.09.2023

Offered and passage moved by.

[Signature] Aye Nay Abstain Absent
Dorothy McCumber

[Signature] Aye Nay Abstain Absent
John Dietrich

[Signature] Aye Nay Abstain Absent
Brian Peper

[Signature] Aye Nay Abstain Absent
Carl Gruber

[Signature] Aye Nay Abstain Absent
Marty Krueger

Fiscal Note: The budget includes Per Diem and mileage expense for committee meetings.

MIS Note: None

RESOLUTION # 90 - 2023

A resolution to accept additional funding from the Department of Health for the Independent Living Supports Program and to use the funding to increase an 80% Information & Assistance (I & A) to full time equivalent (FTE) and amend the 2024 budget.

Resolution offered by the Aging and Disability Resource Governing Committee, Finance Committee, and Personnel & Insurance Committee.

Resolved by the Board of Supervisors of Sauk County, Wisconsin:

BACKGROUND: The Sauk County Aging and Disability Resource Center was awarded the Independent Living Supports Program grant in March of 2023. Due to unforeseen issues, the grant has been more cumbersome to administer than the state initially planned. As a result, the Department of Health has offered more administrative funding to the ADRC.

One of the ADRC's Information & Assistance Specialists works an .80 FTE. She has agreed to go to full time January 1, 2024, devoting .20 FTE to the Independent Living Supports Program. The funding will only last one year and she has agreed to return to .80 FTE in 2025. The funding covers 20% of wages and benefits.

NOW, THEREFORE, BE IT RESOLVED, that effective January 1, 2024, the .80 FTE Information & Assistance Specialist will be reclassified to full time for the year 2024 only. The additional .20 FTE will be devoted to the Independent Living Supports Program.

BE IT FURTHER RESOLVED, that the 2024 ADRC budget will be amended to include \$24,044.00; \$17,192.00 in wages and \$6,852.00 in Fringe. No levy is required.

Approved for presentation to the County Board this 19th day of December 2023.

Consent Agenda Item [] YES [] NO

Fiscal Impact: [] None [] Budgeted Expenditure [X] Not Budgeted

Vote Required: Majority= _____ 2/3 Majority= [X] 3/4 Majority= _____

The County Board has the legal authority to adopt: Yes [X] No _____ as reviewed by the Corporation Counsel, _____

Date: 12.14.2023

Offered and passage moved by:

SAUK COUNTY AGING & DISABILITY RESOURCE CENTER GOVERNING COMMITTEE

Dennis Polivka signature
DENNIS POLIVKA, CHAIR

JUDY ELLINGTON

GAILE BURCHILL

KRISTIN WHITE-EAGLE

52
53
54
55
56
57
58
59
60
61
62
63
64
65
66
67
68
69
70
71
72
73
74
75
76
77
78
79
80
81
82
83
84
85
86
87
88
89
90
91
92
93
94
95
96
97
98
99
100
101
102

ANDREA LOMBARD

LAURIE GRILL

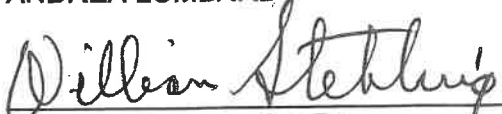
WILLIAM STEHLING

TUT GRAMBLING

THOMAS DOERNER

TERESA WOLKOWSKI

PERSONNEL & INSURANCE COMMITTEE

FINANCE COMMITTEE

CARL GRUBER, CHAIR

MARTY KRUEGER, CHAIR



PETER KINSMAN

RICHARD "MIKE" FLINT

TERRY SPENCER

LYNN EBERL

ROBERT PROSSER

THOMAS DOERNER

JAMES ROXEN

TIMOTHY MCCUMBER

Fiscal Note: The program cost and funding for these additional funds in 2024 is \$24,044.00 

Program funding (DHS)	\$24,044.00
Budgeted Levy	\$0.00
General Fund Balance	\$0.00
TOTAL	\$24,044.00

Program Expenses	
.20 FTE Staff	\$17,192.00
Benefits	\$6,852.00
MIS	0.00
Training/mileage/supplies	0.00
TOTAL	\$24,044.00

MIS Note: No information systems impact.

RESOLUTION # 91 - 2023

Resolution Accepting a Hazard Mitigation Grant, authorizing a Contract with Civi Tek Consulting, LLC For Hazard Mitigation Plan Updates, included in the 2024 Budget.

Resolution offered by the Executive and Legislative Committee

Resolved by the Board of Supervisors of Sauk County, Wisconsin:

BACKGROUND: Sauk County is required to maintain a plan to mitigate potential hazards. The Federal Emergency Management Agency (FEMA) requires that the County's plan be updated every five years. This plan was last updated in 2019 by Civi Tek Consulting, LLC and expires in 2024. As Civi Tek Consulting LLC developed the existing plan, they are best positioned to perform the current update. To reduce costs, FEMA and Wisconsin Emergency Management recommended the use of a prior contractor. On October 2, 2023, the Federal Emergency Management Agency, working through Wisconsin Emergency Management, awarded Sauk County Emergency Management up to \$34,188.88 for the plan update. Federal award is \$25,641.66 (75%), Sauk County match is \$8,547.22 (25%).

THEREFORE, BE IT RESOLVED, by the Sauk County Board of Supervisors, met in regular session, that the grant is accepted for hazard mitigation planning and a contract with Civi Tek Consulting, LLC for a total of \$34,188.88 is hereby approved; and,

BE IT FURTHER RESOLVED that Sauk County Administrator is authorized to enter in a contract with Civi Tek Consulting LLC for Hazard Mitigation Plan Updates.

Approved for presentation to the County Board by the Executive and Legislative Committee, this 5th Day of December, 2023.

Consent Agenda Item: [] YES [X] NO

Fiscal Impact: [] None [X] Budgeted Expenditure [] Not Budgeted

Vote Required: Majority = X 2/3 Majority = _____ 3/4 Majority = _____

The County Board has the legal authority to adopt: Yes X No _____ as reviewed by the Corporation Counsel, _____, Date:

12.09.2023
12

Offered and passage moved by:

[Signature] Aye Nay Abstain Absent
Timothy McCumber

[Signature] Aye Nay Abstain Absent
John M. Dietrich

[Signature] Aye Nay Abstain Absent
Brian L. Peper

52
53
54
55
56
57
58
59
60
61
62
63
64

Carl Gruber Aye Nay Abstain Absent

Marty Krueger Aye Nay Abstain Absent

Fiscal Note: Federal Grant funds of \$25,641.66 (75%) will be received to fund update to Sauk County's Hazard Mitigation Plan. In-kind match of 2024 budget will be used to meet the County's responsibility in the amount of \$8,547.22 (25%) for a total expenditure of \$34,188.88.

MIS Note: No MIS Note.

RESOLUTION # 92 - 2023

Resolution Authorizing the Purchase of a Replacement Electronic Health Records System for the Health Department and Amending the 2024 Budget

Resolution offered by the Finance Committee, Executive and Legislative Committee, and the Sauk County Board of Health.

Resolved by the Board of Supervisors of Sauk County, Wisconsin:

BACKGROUND: Sauk County Public Health utilizes an Electronic Health Records system (EHR) purchased in 2012 to support the provision of Home Care Services, which were the primary focus of the Health Department at that time. Today the Department no longer provides these services, and this system lacks the functionality necessary to meet the Department's current business requirements.

In September, the MIS Department initiated a Request for Proposal for a replacement system. This resulted in the receipt of proposals from six vendors. After a careful review by the Health Department, it was determined that the proposed system from Champ Software, INC (Nightingale Notes EHR) was the best system proposed to support the provision of Public Health Services by Sauk County.

NOW THEREFORE, BE IT RESOLVED, by the Sauk County Board of Supervisors, that the purchase of Nightingale Notes EHR software from Champ Software, INC, at an initial cost of \$51,797, and estimated recurring annual support and licensing fees of \$34,097, be hereby approved; and,

BE IT FURTHER RESOLVED, that the 2024 Sauk County Budget for the Health Department be amended to include \$51,797 from the Public Health Workforce Grant to support the acquisition of this system; and,

BE IT FURTHER RESOLVED, that the Sauk County MIS Director is delegated the authority to enter into any agreements related to the purchase of said system on behalf of Sauk County.

Approved for presentation to the County Board by the Sauk County Board of Health and the Executive and Legislative and Finance Committees, this 19th day of December 2023.

Consent Agenda Item: [] YES [X] NO

Fiscal Impact: [] None [] Budgeted Expenditure [X] Not Budgeted

Vote Required: Majority = _____ 2/3 Majority = X 3/4 Majority = _____

The County Board has the legal authority to adopt: Yes X No _____ as reviewed by the Corporation Counsel, _____, Date: 12.14.2023

Offered and passage moved by:

52
53
54
55
56
57
58
59
60
61
62
63
64
65
66
67
68
69
70
71
72
73
74
75
76
77
78
79
80
81
82
83
84
85
86
87
88
89
90
91
92
93
94
95
96
97
98
99
100
101
102

Sauk County Board of Health:

Pat Rego Aye Nay Abstain Absent

Rebecca Klitzke Aye Nay Abstain Absent

Thomas Dorner Aye Nay Abstain Absent

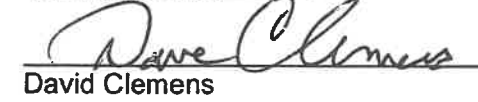

David Clemens Aye Nay Abstain Absent

N/A
Dr. Angela Hanley Aye Nay Abstain Absent

Kiana Li Beaudin Aye Nay Abstain Absent

Dr. Barclay Shultz Aye Nay Abstain Absent

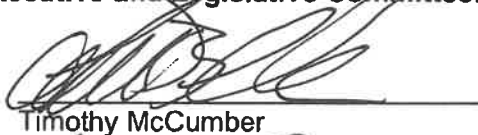
Executive and Legislative Committee:

Timothy McCumber Aye Nay Abstain Absent

John M. Dietrich Aye Nay Abstain Absent

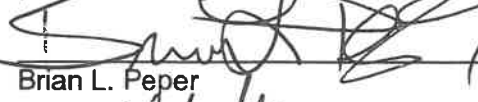
Brian L. Peper Aye Nay Abstain Absent

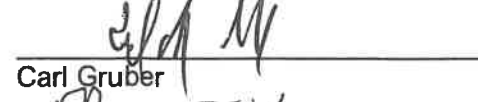
Carl Gruber Aye Nay Abstain Absent

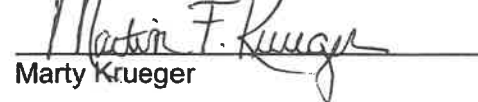
Marty Krueger Aye Nay Abstain Absent

103
104
105
106
107
108
109
110
111
112
113
114
115
116
117
118
119
120
121
122
123
124
125
126
127
128
129
130
131
132
133
134
135

Finance Committee:

<u>Marty F. Krueger</u> Marty Krueger	<input checked="" type="checkbox"/> Aye	<input type="checkbox"/> Nay	<input type="checkbox"/> Abstain	<input type="checkbox"/> Absent
<u>Richard "Mike" Flint</u> Richard "Mike" Flint	<input checked="" type="checkbox"/> Aye	<input type="checkbox"/> Nay	<input type="checkbox"/> Abstain	<input type="checkbox"/> Absent
<u>Lynn Eberl</u> Lynn Eberl	<input checked="" type="checkbox"/> Aye	<input type="checkbox"/> Nay	<input type="checkbox"/> Abstain	<input type="checkbox"/> Absent
<u>Thomas Dörner</u> Thomas Dörner	<input checked="" type="checkbox"/> Aye	<input type="checkbox"/> Nay	<input type="checkbox"/> Abstain	<input type="checkbox"/> Absent
<u>Timothy McCumber</u> Timothy McCumber	<input type="checkbox"/> Aye	<input type="checkbox"/> Nay	<input type="checkbox"/> Abstain	<input type="checkbox"/> Absent

Fiscal Note:

The \$51,797 for the acquisition of the system in 2024 will be derived from the Public Health Workforce Grant revenue. Subsequent annual costs for licensing and support, estimated to be \$34,097, will be budgeted from tax levy.

The support cost for the current system is approximately \$27,000 annually. This will be discontinued once the new system is in place. *JMH*

MIS Note:

The proposed system is cloud-based and does not require the purchase of additional hardware infrastructure to support system operation.

Three Year Cost of Ownership Comparison - Health Dept EHR

Type	Vendor	Project Elements	One Time Costs	Year 1	Year 2	Subsequent Years	Est 3 YR TCO*
	<u>Softbir</u>						
		Impelmentation	145,000				
		Integrations	15,000				
		Customizations					
		Training	25,000				
		Requirements Gathering					
		Licensing		25,000	25,000	25,000	77,000
		Support			12,000	12,000	24,000
		Maintenance			7,500	7,500	15,000
		Hosting			32,500	32,500	65,000
		Data Migration	5,000				
		Integrations	5,000				
		Softbir Totals	195,000	25,000	77,000	77,000	374,000
	<u>Syra Health</u>						
		System Installation	236,040				
		Training		4,800	4,800	4,800	14,400
		Infrastructure Costs		42,000	42,000	42,000	126,000
		Licensing		60,000	60,000	60,000	180,000
		Syra Health Totals	236,040	106,800	106,800	106,800	556,440
	<u>Patagonia Health</u>						
		System Build	49,880				
		Training	11,000				
		License / Hosting / Support		40,739	50,742	52,579	144,060
		Patagonia Totals	60,880	40,739	50,742	52,579	204,940

Type	Vendor	Project Elements	One Time Costs	Year 1	Year 2	Subsequent Years	Est 3 YR TCO*
	E*HealthLine						
		Licensing	354,800				
		Installation	116,850				
		Third Party SW	39,806				
		Training	17,300				
		Maintenance / Support		47,398	47,398	47,398	
		E*HealthLine Totals	528,756	47,398	47,398	47,398	670,950
	Data Systems Integrations						
		System Installation	695,500				
		Perpetual License		34,000	105,050	108,212	
		Data Systems Integrations Totals	695,500	34,000	105,050	108,212	942,762
	Champ Software						
		System Installation	6,000				
		Training	10,200				
		Licensing		30,813	30,813	30,813	
		zoom Professional lic		1,800	1,800	1,800	
		Activity Clearing House		660	660	660	
		Teletask Auto Messaging		500	500	500	
		Acuity Self Scheduling		324	324	324	
		SSO	1,500				
		Champ Software Totals	17,700	34,097	34,097	34,097	119,991

* TCO figures are based upon estimated annual support quotes - actual year 2 and year 3 annual costs may vary depending upon the term of the support contract.

1
2
3 **GENERAL CODE OF SAUK COUNTY, WISCONSIN**
4 **ORDINANCE AMENDMENT # 9 - 2023**
5

6 **Ordinance Amendment to approve a map amendment (rezoning) of lands in the**
7 **Town of Ironton from an Agriculture to an Exclusive Agriculture Zoning District filed**
8 **upon Gerald and Linda White, property owners.**
9

10 **Ordinance Amendment offered by the Land Resources and Environment Committee**
11

12 **BACKGROUND:**
13

14 Background: Gerald and Linda White own property in the NW ¼, SW ¼, Section 13, T12N,
15 R3E, Town of Ironton, and has requested a map amendment (rezoning) of property legally
16 described pursuant to petition 10-2023 from an Agriculture zoning district to an Exclusive
17 Agriculture zoning district. The intent of the map amendment (rezoning) being to revert
18 the property to the previous Exclusive Agriculture zoning after a previous use has been
19 discontinued.
20

21 Pursuant to Wis. Stat. §59.69(5) Sauk County has the authority to develop, adopt, and
22 amend a zoning ordinance. At a public hearing held by the Land Resources and
23 Environment (LRE) Committee on November 28, 2023; the LRE Committee made findings
24 pursuant to Sauk County Code of Ordinance §7.150(9) and recommended approval of the
25 map amendment.
26

27 Pursuant to Wis. Stat. §66.1001 Wisconsin Statutes, any program or action of a local
28 governmental unit that affects land use shall be consistent with the comprehensive plan.
29 The Sauk County Comprehensive Plan, adopted by the Sauk County Board of Supervisors
30 in 2009, defines managing and focusing "on efficient land use patterns that promotes
31 redevelopment of under-utilized lands. It sets limits on outward growth, incorporates
32 permanent land preservation techniques, and achieves livable communities." Upon
33 evaluation of the request, the Land Resources and Environment Committee found that the
34 rezone request to an Exclusive Agriculture zoning district maintains this objective.
35

36 **NOW, THEREFORE, THE SAUK COUNTY BOARD OF SUPERVISORS DOES**
37 **ORDAIN AS FOLLOWS:**

38 Section 1. Any existing ordinances, codes, resolutions, or portions thereof in
39 conflict with this ordinance shall be and hereby are repealed as far as any conflict exists.

40 Section 2. This ordinance shall take effect the day after passage and publication
41 as required by law.

42 Section 3. If any claims, provisions or portions of this ordinance are adjudged
43 unconstitutional or invalid by a court of competent jurisdiction, the remainder of this
44 ordinance shall not be affected thereby.

45 Section 4. Section 7.005(2) Official Zoning Map of the General Code of Sauk
46 County, Wisconsin, is amended as follows:
47

48 Rezone of approximately 2.066 acres of tax parcels 022-0315-00000 and 022-0315-
49 10000 from an Agriculture Zoning District to an Exclusive Agriculture Zoning District.
50

51 Approved for presentation to the County Board by the Land Resources and Environment

52 Committee this 19th day of December 2023.

53

54 Consent Agenda Item: [] YES [X] NO

55

56 Fiscal Impact: [X] None [] Budgeted Expenditure [] Not Budgeted

57

58 Vote Required: Majority = X 2/3 Majority = _____ 3/4 Majority = _____

59

60 The County Board has the legal authority to adopt: Yes X No _____ as
61 reviewed by the Corporation Counsel, [Signature], Date:
62 12.12.2023.

63

64

65 Offered and passage moved by:

66

67 [Signature] Aye Nay Abstain Absent
68 MARTY KRUEGER, CHAIR

69

70 [Signature] Aye Nay Abstain Absent
71 PETER KINSMAN, VICE CHAIR

72

73 [Signature] Aye Nay Abstain Absent
74 DENNIS POLIVKA

75

76 [Signature] Aye Nay Abstain Absent
77 ROBERT SPENCER

78

79 [Signature] Aye Nay Abstain Absent
80 BRANDON LOHR

81

82 [Signature] Aye Nay Abstain Absent
83 LYNN EBERL

84

85 [Signature] Aye Nay Abstain Absent
86 VALERIE MCAULIFFE

87

88

89

90

91

92

93

94

95

96 Fiscal Note:

97

98 MIS Note:

1
2
3 **GENERAL CODE OF SAUK COUNTY, WISCONSIN**
4 **ORDINANCE AMENDMENT # 10-2023**
5

6 **Ordinance Amendment to approve a map amendment (rezoning) of lands in the**
7 **Town of Baraboo from a Commercial to a Resource Conservancy Zoning District**
8 **filed upon John Wells, property owner.**
9

10 **Ordinance Amendment offered by the Land Resources and Environment Committee**
11

12 **BACKGROUND:**
13

14 Background: John Wells owns property in the NW ¼, NE ¼, and NE ¼, NE ¼, Section 21,
15 T12N, R6E, Town of Baraboo, and has requested a map amendment (rezoning) of
16 property legally described pursuant to petition 15-2023 from a Commercial zoning district
17 to a Resource Conservancy zoning district. The intent of the map amendment (rezoning)
18 being to allow for the construction of a single-family residence.
19

20 Pursuant to Wis. Stat. §59.69(5) Sauk County has the authority to develop, adopt, and
21 amend a zoning ordinance. At a public hearing held by the Land Resources and
22 Environment (LRE) Committee on November 28, 2023; the LRE Committee made findings
23 pursuant to Sauk County Code of Ordinance §7.150(9) and recommended approval of the
24 map amendment.
25

26 Pursuant to Wis. Stat. §66.1001 Wisconsin Statutes, any program or action of a local
27 governmental unit that affects land use shall be consistent with the comprehensive plan.
28 The Sauk County Comprehensive Plan, adopted by the Sauk County Board of Supervisors
29 in 2009, defines managing and focusing "on efficient land use patterns that promotes
30 redevelopment of under-utilized lands. It sets limits on outward growth, incorporates
31 permanent land preservation techniques, and achieves livable communities." Upon
32 evaluation of the request, the Land Resources and Environment Committee found that the
33 rezone request to a Resource Conservancy zoning district maintains this objective.
34

35 **NOW, THEREFORE, THE SAUK COUNTY BOARD OF SUPERVISORS DOES**
36 **ORDAIN AS FOLLOWS:**

37 Section 1. Any existing ordinances, codes, resolutions, or portions thereof in
38 conflict with this ordinance shall be and hereby are repealed as far as any conflict exists.

39 Section 2. This ordinance shall take effect the day after passage and publication
40 as required by law.

41 Section 3. If any claims, provisions or portions of this ordinance are adjudged
42 unconstitutional or invalid by a court of competent jurisdiction, the remainder of this
43 ordinance shall not be affected thereby.

44 Section 4. Section 7.005(2) Official Zoning Map of the General Code of Sauk
45 County, Wisconsin, is amended as follows:
46

47 Rezone of tax parcel 002-0633-10000 from a Commercial Zoning District to a Resource
48 Conservancy Zoning District.
49

50 Approved for presentation to the County Board by the Land Resources and Environment
51 Committee this 19th day of December, 2023.

52
53
54
55
56
57
58
59
60
61
62
63
64
65
66
67
68
69
70
71
72
73
74
75
76
77
78
79
80
81
82
83
84
85
86
87
88
89
90
91
92
93
94
95
96
97

Consent Agenda Item: [] YES [X] NO

Fiscal Impact: [X] None [] Budgeted Expenditure [] Not Budgeted

Vote Required: Majority = X 2/3 Majority = _____ 3/4 Majority = _____

The County Board has the legal authority to adopt: Yes X No _____ as reviewed by the Corporation Counsel, [Signature] , Date: 12-12-2023 .

Offered and passage moved by:

[Signature: Martin F. Krueger] Aye Nay Abstain Absent
MARTY KRUEGER, CHAIR

[Signature: Peter Kinsman] Aye Nay Abstain Absent
PETER KINSMAN, VICE CHAIR

[Signature: Dennis Polivka] Aye Nay Abstain Absent
DENNIS POLIVKA

[Signature: Robert Spencer] Aye Nay Abstain Absent
ROBERT SPENCER

[Signature: Brandon Loehr] Aye Nay Abstain Absent
BRANDON LOHR

[Signature: Lynn Eberl] Aye Nay Abstain Absent
LYNN EBERL

[Signature: Valerie McAuliffe] Aye Nay Abstain Absent
VALERIE MCAULIFFE

Fiscal Note:

MIS Note:

1
2
3 **GENERAL CODE OF SAUK COUNTY, WISCONSIN**
4 **ORDINANCE AMENDMENT # 11-2023**
5

6 **Ordinance Amendment to approve a map amendment (rezoning) of lands in the**
7 **Town of La Valle from an Agriculture to a Commercial Zoning District filed upon**
8 **Jay's Holdings LLC, property owner.**
9

10 **Ordinance Amendment offered by the Land Resources and Environment Committee**
11

12 **BACKGROUND:**
13

14 Background: Jay's Holdings LLC owns property in the SW ¼, SW ¼, Section 21, T13N,
15 R3E, Town of La Valle, and has requested a map amendment (rezoning) of property
16 legally described pursuant to petition 13-2023 from an Agriculture zoning district to a
17 Commercial zoning district. The intent of the map amendment (rezoning) being to expand
18 an existing commercial zoning district by 7.9 acres to expand a warehouse facility for
19 storage of boats, utv's, and campers.
20

21 Pursuant to Wis. Stat. §59.69(5) Sauk County has the authority to develop, adopt, and
22 amend a zoning ordinance. At a public hearing held by the Land Resources and
23 Environment (LRE) Committee on November 28, 2023; the LRE Committee made findings
24 pursuant to Sauk County Code of Ordinance §7.150(9) and recommended approval of the
25 map amendment.
26

27 Pursuant to Wis. Stat. §66.1001 Wisconsin Statutes, any program or action of a local
28 governmental unit that affects land use shall be consistent with the comprehensive plan.
29 The Sauk County Comprehensive Plan, adopted by the Sauk County Board of Supervisors
30 in 2009, defines managing and focusing "on efficient land use patterns that promotes
31 redevelopment of under-utilized lands. It sets limits on outward growth, incorporates
32 permanent land preservation techniques, and achieves livable communities." Upon
33 evaluation of the request, the Land Resources and Environment Committee found that the
34 rezone request to a Commercial zoning district maintains this objective.
35

36 **NOW, THEREFORE, THE SAUK COUNTY BOARD OF SUPERVISORS DOES**
37 **ORDAIN AS FOLLOWS:**

38 Section 1. Any existing ordinances, codes, resolutions, or portions thereof in
39 conflict with this ordinance shall be and hereby are repealed as far as any conflict exists.

40 Section 2. This ordinance shall take effect the day after passage and publication
41 as required by law.

42 Section 3. If any claims, provisions or portions of this ordinance are adjudged
43 unconstitutional or invalid by a court of competent jurisdiction, the remainder of this
44 ordinance shall not be affected thereby.

45 Section 4. Section 7.005(2) Official Zoning Map of the General Code of Sauk
46 County, Wisconsin, is amended as follows:
47

48 Rezone of approximately 7.9 acres of tax parcel 024-0569-10000 from an Agriculture
49 Zoning District to a Commercial Zoning District.
50

51 Approved for presentation to the County Board by the Land Resources and Environment

52 Committee this 19th day of December, 2023.

53

54 Consent Agenda Item: [] YES [X] NO

55

56 Fiscal Impact: [X] None [] Budgeted Expenditure [] Not Budgeted

57

58 Vote Required: Majority = X 2/3 Majority = _____ 3/4 Majority = _____

59

60 The County Board has the legal authority to adopt: Yes X No _____ as
61 reviewed by the Corporation Counsel, [Signature] , Date:
62 12.12.2023

63

64

65

66 Offered and passage moved by:

67

68 [Signature] Aye Nay Abstain Absent

69

70

71 [Signature] Aye Nay Abstain Absent

72

73

74 [Signature] Aye Nay Abstain Absent

75

76

77 [Signature] Aye Nay Abstain Absent

78

79

80 [Signature] Aye Nay Abstain Absent

81

82

83 [Signature] Aye Nay Abstain Absent

84

85

86 [Signature] Aye Nay Abstain Absent

87

88

89

90

91

92

93

94

95

96

97

98

Fiscal Note:

MIS Note:

RESOLUTION# 93-2023

Resolution to deny a proposed rezone petition 14-2023

Resolution offered by the Land Resources and Environment Committee

Resolved by the Board of Supervisors of Sauk County, Wisconsin:

BACKGROUND: Clayton Yoder owns property in the NW ¼, NE ¼, Section 35, T11N, R4E, Town of Westfield, and has requested a map amendment (rezoning) of property legally described pursuant to petition 14-2023 from an Exclusive Agriculture zoning district to an Agriculture zoning district. The intent of the map amendment (rezoning) is to allow the property owner to apply for a permit for a kennel.

Pursuant to Wis. Stat. §59.69(5) Sauk County has the authority to develop, adopt, and amend a zoning ordinance. A public hearing held by the Land Resources and Environment (LRE) Committee on November 28, 2023. On December 14, 2023 the LRE Committee made findings pursuant to Sauk County Code of Ordinance §7.150(9) and recommended denial rezone petition 14-2023.

The Land Resources and Environment Committee, being fully informed of the facts and after full consideration of the matter, made the following findings and recommendation, which the Sauk County Board of Supervisors has determined are reasonable. The Land Resources and Environment Committee reviewed §7.150(9) of the Sauk County Zoning Ordinance. The Committee concluded the following:

- 1. The uses permitted by the proposed map amendment (rezoning) are not appropriate for the area.
- 2. The land is not better suited for a use not allowed in the exclusive agriculture district.

THEREFORE, BE IT RESOLVED, by the Sauk County Board of Supervisors accepts the foregoing as the Land Resources and Environment report recommending denial of rezone petition 14-2023, to rezone property from Exclusive Agriculture Zoning District to Agriculture Zoning District described as NW ¼, NE ¼, Section 35, T11N, R4E, Town of Westfield.

BE IT FURTHER RESOLVED, by the Sauk County Board of Supervisors that rezone petition 14-2023, to rezone property from Exclusive Agriculture Zoning District to Agriculture Zoning District described as NW ¼, NE ¼, Section 35, T11N, R4E, Town of Westfield is hereby denied. Within seven (7) days of passage, the County Clerk shall send a certified copy along with the final results of the County Board's decision to the petitioner and the Westfield Town Clerk.

Approved for presentation to the County Board by the Land Resources and Environment Committee this 19th day of December, 2023.

Consent Agenda Item: [] YES [X] NO



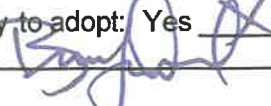

Fiscal Impact: [X] None [] Budgeted Expenditure [] Not Budgeted

Vote Required: Majority = X 2/3 Majority = _____ ¾ Majority = _____

52
53
54
55
56
57
58
59
60
61
62
63
64
65
66
67
68
69
70
71
72
73
74
75
76
77
78
79
80
81
82
83
84
85
86
87
88
89
90
91

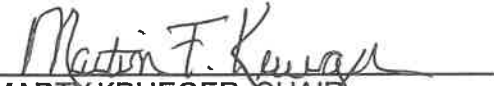
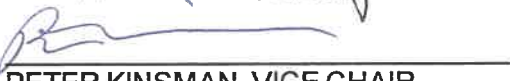
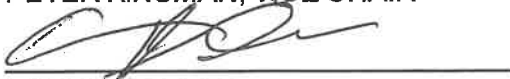
The County Board has the legal authority to adopt: Yes No _____ as reviewed by the Corporation Counsel, , Date: 12.14.2023.

Offered and passage moved by:

<u></u> MARTY KRUEGER, CHAIR	<input checked="" type="checkbox"/> Aye	<input type="checkbox"/> Nay	<input type="checkbox"/> Abstain	<input type="checkbox"/> Absent
<u></u> PETER KINSMAN, VICE CHAIR	<input checked="" type="checkbox"/> Aye	<input type="checkbox"/> Nay	<input type="checkbox"/> Abstain	<input type="checkbox"/> Absent
<u></u> DENNIS POLIVKA	<input checked="" type="checkbox"/> Aye	<input type="checkbox"/> Nay	<input type="checkbox"/> Abstain	<input type="checkbox"/> Absent
_____ ROBERT SPENCER	<input type="checkbox"/> Aye	<input type="checkbox"/> Nay	<input type="checkbox"/> Abstain	<input checked="" type="checkbox"/> Absent
<u></u> BRANDON LOHR	<input checked="" type="checkbox"/> Aye	<input type="checkbox"/> Nay	<input type="checkbox"/> Abstain	<input type="checkbox"/> Absent
<u></u> LYNN EBERL	<input checked="" type="checkbox"/> Aye	<input type="checkbox"/> Nay	<input type="checkbox"/> Abstain	<input type="checkbox"/> Absent
<u></u> VALERIE MCAULIFFE	<input checked="" type="checkbox"/> Aye	<input type="checkbox"/> Nay	<input type="checkbox"/> Abstain	<input type="checkbox"/> Absent

Fiscal Note: No impact Just

MIS Note:

RESOLUTION # 94 - 2023

Resolution Authorizing the County Administrator to Submit Multi-Discharger Variance Application to the Wisconsin Department of Natural Resources.

Resolution offered by the Land Resources and Environment Committee

Resolved by the Board of Supervisors of Sauk County, Wisconsin:

BACKGROUND: The multi-discharger variance (MDV) for phosphorus extends the timeline for Wisconsin Pollutant Discharge Elimination System (WPDES) permitted facilities with complying with low-level phosphorus limits. In exchange, these facilities commit to stepwise reductions of phosphorus within their effluent as well as helping to address nonpoint sources of phosphorus from farm fields, cities or natural areas to implement projects designed to improve water quality. Sauk County Land Resources and Environment Department and various WPDES permit holders are pursuing an approach to address reductions of phosphorus in the Baraboo River and Lower Wisconsin Watersheds through MDV watershed projects. Actual funding amounts are not made available until January 1 of any given year.

WHEREAS, Pursuant to s. 283.16, Wis. Stats, the MDV application must be submitted by Sauk County annually to determine eligibility to receive multi-discharger variance (MDV) funds; and

NOW, THEREFORE, BE IT RESOLVED, by the Sauk County Board of Supervisors, met in regular session, that Sauk County continues to support the installation of conservation practices that prevent phosphorus pollution caused by soil erosion and agricultural runoff to protect groundwater surface water resources; and,

BE IT FURTHER RESOLVED, that the County Administrator is hereby authorized to submit the MDV application.

Approved for presentation to the County Board by the Land Resources and Environment Committee, this 19th day of December 2023.

Consent Agenda Item: [] YES [] NO

Fiscal Impact: [] None [X] Budgeted Expenditure [] Not Budgeted

Vote Required: Majority = X 2/3 Majority = _____ 3/4 Majority = _____

The County Board has the legal authority to adopt: Yes X No _____ as reviewed by the Corporation Counsel, _____, Date: 12-12-2023.

Offered and passage moved by: Land Resources and Environment Committee

Marty Krueger, Chair [X] Aye [] Nay [] Abstain [] Absent

Peter Kinsman, Vice Chair [X] Aye [] Nay [] Abstain [] Absent

52
53
54
55
56
57
58
59
60
61
62
63
64
65
66
67
68
69
70
71
72
73
74
75

_____ Aye Nay Abstain Absent

Brandon Lohr

_____ Aye Nay Abstain Absent

Dennis Polivka

_____ Aye Nay Abstain Absent

Robert Spencer

_____ Aye Nay Abstain Absent

Valerie McAuliffe

_____ Aye Nay Abstain Absent

Lynn Eberl

_____ Aye Nay Abstain Absent

Randy Puttkamer

Fiscal Note: The proposed 2024 Land Resources and Environment Department budget shows potential funding amounts of \$22,951. Final funding amounts depend upon participation of other counties in the watershed and will not be available until after January 1, 2024.

MIS Note: No Impact

RESOLUTION # 95-2023

Resolution to Authorize Continued County Participation in the Wildlife Damage Abatement Program and the Wildlife Damage Claim Program

Resolution offered by the Land Resources and Environment Committee

Resolved by the Board of Supervisors of Sauk County, Wisconsin:

BACKGROUND: The U.S. Department of Agriculture (USDA) is authorized to protect American agriculture and other resources from damage associated with wildlife. The primary authority for Animal Plant Health Inspection Service – Wildlife Services (APHIS-WS) is the Act of March 2, 1931 (46 Stat. 1468; 7 U.S.C.426-426b) as amended, and the Act of December 22, 1987 (101 Stat. 1329-331, 7 U.S.C. 426c). The APHIS-WS program was designed to cooperate with states, local jurisdictions, individuals, public and private agencies, organizations, and institutions to conduct a program of wildlife services involving mammal and bird species that are reservoirs for zoonotic diseases or animal species that are injurious and/or a nuisance to, among other things; agriculture, horticulture, forestry, animal husbandry, wildlife, and human health and safety. In 1983, the Wisconsin State Legislature established the Wildlife Damage Abatement Claim Program (WDACP) through the Wisconsin Department of Natural Resources (WDNR) to work in partnership with the USDA on wildlife damage efforts in Wisconsin. Wisconsin Statute 29.889 (4)(a) identifies that in order to be eligible for wildlife damage abatement assistance, the land for which assistance is sought is required to be located in a county which is participating in the administration of the wildlife damage abatement program. Sauk County has participated in the APHIS-WS program since 1984 and is required to sign a five-year Cooperative Service Agreement effective January 1, 2024, through December 31, 2028.

THEREFORE, BE IT RESOLVED, that the Sauk County Board of Supervisors, met in regular session, hereby authorizes the Administrator to sign a Cooperative Agreement (attached) with the WDNR and the USDA to administer the APHIS-WS program from January 1, 2024 through December 31, 2028, in partnership with the WDNR and USDA; and,

BE IT FURTHER RESOLVED, that the Sauk County Board of Supervisors designates the Land Resources and Environment Committee as the oversight committee per the requirements of Section III of the Cooperative Service Agreement.

Approved for presentation to the County Board by the Land Resources and Environment Committee, this 19th day of December, 2023.

Consent Agenda Item: [] YES [] NO

Fiscal Impact: [] None [X] Budgeted Expenditure [] Not Budgeted

Vote Required: Majority = X 2/3 Majority = _____ 3/4 Majority = _____

The County Board has the legal authority to adopt: Yes X No _____ as reviewed by the Corporation Counsel, [Signature], Date: 12.12.2023

52
53
54
55
56
57
58
59
60
61
62
63
64
65
66
67
68
69
70
71
72
73
74
75
76
77
78
79
80
81
82

Offered and passage moved by:



Marty Krueger, Chair Aye Nay Abstain Absent

Peter Kinsman, Vice Chair Aye Nay Abstain Absent

Brandon Lohr Aye Nay Abstain Absent

Dennis Polivka Aye Nay Abstain Absent

Robert Spencer Aye Nay Abstain Absent

Valerie McAuliffe Aye Nay Abstain Absent

Lynn Eberl Aye Nay Abstain Absent

Randy Puttkamer Aye Nay Abstain Absent

Fiscal Note: Funds for this program are reimbursed by the WDNR on an annual basis. The proposed 2024 LRE budget contains \$20,017. Minimal staff time is used in the administration of this program.

MIS Note: No impact.

COOPERATIVE SERVICE AGREEMENT
between
SAUK County
and
WISCONSIN DEPARTMENT OF NATURAL RESOURCES (WDNR)
and
UNITED STATES DEPARTMENT OF AGRICULTURE
ANIMAL AND PLANT HEALTH INSPECTION SERVICE (APHIS)
WILDLIFE SERVICES (WS)

ARTICLE 1 – PURPOSE

The purpose of this Cooperative Service Agreement is to cooperate in a County/State/Federal black bear, white-tailed deer, elk, cougar, Canada goose, wild turkey and Sandhill crane damage management program. The primary objective is to provide commercial agricultural producers the necessary technical and/or operational assistance in identifying, abating, managing, and assessing damage with the species listed.

ARTICLE 2 – AUTHORITY

APHIS-WS has statutory authority under the Acts of March 2, 1931, 46 Stat. 1468-69, 7 U.S.C. §§ 8351-8352, as amended, and December 22, 1987, Public Law No. 100-202, § 101(k), 101 Stat. 1329-331, 7 U.S.C. § 8353, to cooperate with States, local jurisdictions, individuals, public and private agencies, organizations, and institutions while conducting a program of wildlife services involving mammal and bird species that are reservoirs for zoonotic diseases, or animal species that are injurious and/or a nuisance to, among other things, agriculture, horticulture, forestry, animal husbandry, wildlife, and human health and safety.

ARTICLE 3 - MUTUAL RESPONSIBILITIES

The cooperating parties mutually understand and agree to/that:

1. APHIS-WS shall perform services set forth in the Work Plan, which is attached hereto and made a part hereof. The parties may mutually agree in writing, at any time during the term of this agreement, to amend, modify, add or delete services from the Work Plan.
2. The Cooperator certifies that APHIS-WS has advised the Cooperator there may be private sector service providers available to provide wildlife damage management (WDM) services that the Cooperator is seeking from APHIS-WS.
3. All equipment with a purchase price of \$5,000 or more per unit, purchased directly with funds from the cooperator for use on this ~~78~~ project shall be subject to disposal according to

APHIS policy, and shall be specifically listed in the attached work plan and financial plan. Property title/disposal shall be determined when this project (including all continuations and revisions of this agreement) terminates, or when the equipment is otherwise directed to other projects, whichever comes first. If the equipment is sold prior to the project end, the proceeds should be allocated according to APHIS policy. Continuations and revisions to this agreement shall list any equipment with a purchase price of \$5,000 or more per unit, carried over from a purchase directly with funds from the cooperator for use on this project. All other equipment purchased for the program is and will remain the property of APHIS-WS.

4. The cooperating parties agree to coordinate with each other before responding to media requests on work associated with this project.

ARTICLE 4 - COOPERATOR RESPONSIBILITIES

The County (Cooperator) agrees:

1. To designate the following as the authorized representative who shall be responsible for collaboratively administering the activities conducted in this agreement:

County Cooperator Representative:
Melissa Schlupp
West Square Building, Room 248
505 Broadway
Baraboo, WI 53913
608-355-3245
Melissa.schlupp@saukcountywi.gov

WDNR Representative:
Brad Koele
Wildlife Damage Specialist
WDNR Bureau of Wildlife Management
8770 Hwy J
Woodruff, WI 54568
608-576-3914
Bradley.Koele@wisconsin.gov

2. To authorize APHIS-WS to conduct direct control activities and/or technical assistance to reduce commercial agricultural damage associated to wildlife damage caused by the species identified in the Work Plan. Activities are defined in the Work Plan. APHIS-WS will be considered an invitee on the lands controlled by Wildlife Damage Abatement and Claims Program (WDACP) enrollees. These program enrollees will be required to exercise reasonable care to warn APHIS-WS as to dangerous conditions or activities in the project areas.
3. To reimburse APHIS-WS for costs, not to exceed the annually approved amount specified in the Financial Plan. If costs are projected to exceed the amount reflected in the Financial

Plan, the agreement with amended Work Plan and Financial Plan shall be formally revised and signed by all parties before services resulting in additional costs are performed. The Cooperator agrees to pay all costs of services submitted via an invoice from APHIS-WS within 30 days of the date of the submitted invoice(s). Late payments are subject to interest, penalties, and administrative charges and costs as set forth under the Debt Collection Improvement Act of 1996.

4. To provide a Tax Identification Number or Social Security Number in compliance with the Debt Collection Improvement Act of 1996.
5. As a condition of this agreement, the Cooperator ensures and certifies that it is not currently debarred or suspended and is free of delinquent Federal debt.
6. To designate APHIS-WS the County authorized individual whose responsibility shall be coordination and administration of WDACP activities conducted pursuant to this Agreement.
7. To notify APHIS-WS verbally or in writing as far in advance as practical of the date and time of any proposed meeting related to the program.
8. The Cooperator acknowledges that APHIS-WS shall be responsible for administration of APHIS-WS activities and supervision of APHIS-WS personnel. APHIS-WS will recognize the County as the lead cooperator in this Agreement and the WDNR for providing overall program oversight. APHIS-WS will coordinate activities with the County and WDNR.
9. To obtain the appropriate permits for removal activities for species listed in the Work Plan.
10. The Cooperator will not be connected to the USDA APHIS computer network(s).

ARTICLE 5 – APHIS-WS RESPONSIBILITIES

APHIS-WS Agrees:

1. To designate the following as the APHIS-WS authorized representative who shall be responsible for collaboratively administering the activities conducted in this agreement:

Daniel Hirschert
WI State Director
USDA, APHIS, WS
732 Lois Drive
Sun Prairie, WI 53590
608-837-2727
Daniel.L.Hirschert@usda.gov

2. To conduct activities at sites designated by Cooperator as described in the Work Plan, Plan of Administration, and Financial Plans (Attachments A-C). APHIS-WS will provide qualified personnel and other resources necessary to implement the approved WDM activities delineated in the Work Plan, Plan of Administration, and Financial Plan of this agreement.
3. Designate to the County and WDNR the authorized APHIS-WS employee who shall be responsible for the joint administration of the activities conducted pursuant to this Agreement. APHIS-WS employees' rights will be governed by applicable Federal personnel laws, rules, and regulations. County employees' rights will be governed by County ordinances, Personnel Policy, and Union contracts where applicable.
 - a. APHIS-WS will designate the District Supervisor and/or Assistant District Supervisor as the authorized representative who will provide immediate direction and guidance to personnel in performing activities outlined in this Agreement, to include:
 - i. adequate numbers of qualified personnel to initiate and conduct the wildlife damage management activities outlined in the Work Plan of this Agreement.
 - ii. training, technical supervision, and coordination of activities as outlined in the Work Plan of this Agreement.
 - iii. to arrange for office space and provide equipment and other miscellaneous needs for personnel assigned to this program as outlined in the Work Plan of this Agreement.
4. That the performance of wildlife damage management actions by APHIS-WS under this agreement is contingent upon a determination by APHIS-WS that such actions are in compliance with the National Environmental Policy Act, Endangered Species Act, and any other applicable federal statutes. APHIS-WS will not make a final decision to conduct requested wildlife damage management actions until it has made the determination of such compliance.
5. To invoice the County quarterly for actual costs incurred by APHIS-WS during the performance of services agreed upon and specified in the Work Plan. Authorized auditing representatives of the County shall be accorded reasonable opportunity to inspect the accounts and records of APHIS-WS pertaining to such claims for reimbursement to the extent permitted by Federal law and regulations. APHIS-WS agrees to handle cooperative finances and budgeting as outlined in the Financial Plan of this Agreement.

ARTICLE 6 – CONTINGENCY STATEMENT

This agreement is contingent upon the passage by Congress of an appropriation from which expenditures may be legally met and shall not obligate APHIS-WS upon failure of Congress to so appropriate. This agreement may also be reduced or terminated if Congress only provides APHIS-WS funds for a finite period under a Continuing Resolution.

ARTICLE 7 – NON-EXCLUSIVE SERVICE CLAUSE

Nothing in this agreement shall prevent APHIS-WS from entering into separate agreements with any other organization or individual for the purpose of providing wildlife damage management services exclusive of those provided for under this agreement.

ARTICLE 8 – CONGRESSIONAL RESTRICTIONS

Pursuant to Section 22, Title 41, United States Code, no member of or delegate to Congress shall be admitted to any share or part of this agreement or to any benefit to arise therefrom.

ARTICLE 9 – LAWS AND REGULATIONS

This agreement is not a procurement contract (31 U.S.C. 6303), nor is it considered a grant (31 U.S.C. 6304). In this agreement, APHIS-WS provides goods or services on a cost recovery basis to nonfederal recipients, in accordance with all applicable laws, regulations and policies.

ARTICLE 10 – LIABILITY

APHIS-WS assumes no liability for any actions or activities conducted under this agreement except to the extent that recourse or remedies are provided by Congress under the Federal Tort Claims Act (28 U.S.C. 1346(b), 2401(b), and 2671-2680).

ARTICLE 11 – NON-DISCRIMINATION CLAUSE

The United States Department of Agriculture prohibits discrimination in all its programs and activities on the basis of race, color, national origin, age, disability, and where applicable, sex, marital status, familial status, parental status, religion, sexual orientation, genetic information, political beliefs, reprisal, or because all or part of an individual's income is derived from any public assistance program. Not all prohibited bases apply to all programs.

ARTICLE 12 - DURATION, REVISIONS, EXTENSIONS, AND TERMINATIONS

This agreement shall become effective on January 1, 2024 and shall continue through December 31, 2028. This Cooperative Service Agreement may be amended by mutual agreement of the parties in writing. The Cooperator must submit a written request to extend the end date at least 10 days prior to expiration of the agreement. Also, this agreement may be terminated at any time by mutual agreement of the parties in writing, or by one party provided that party notifies the other in writing at least 120 days prior to effecting such action. Further, in the event the Cooperator does not provide necessary funds, APHIS-WS is relieved of the obligation to provide services under this agreement.

In accordance with the Debt Collection Improvement Act of 1996, the Department of Treasury requires a **Taxpayer Identification Number** for individuals or businesses conducting business with the agency.

County Tax ID No.: 39-6005740
WDNR Tax ID No.: 396006436
APHIS-WS's Tax ID: 41-0696271

County:

BY: _____ Date

Name/ Title:
505 Broadway,
Baraboo, WI 53913

Wisconsin Department of Natural Resources:

BY: _____ Date

Eric Lobner, Bureau Director
Wisconsin Department of Natural Resources
101 S. Webster Street
Madison, WI 53707-7921

**UNITED STATES DEPARTMENT OF AGRICULTURE
ANIMAL AND PLANT HEALTH INSPECTION SERVICE
WILDLIFE SERVICES**

BY: _____ Date

Daniel Hirschert, State Director
USDA, APHIS, WS
732 Lois Dr.
Sun Prairie, WI 53590

BY: _____ Date

Keith Wehner, Eastern Region Director
USDA, APHIS, WS
920 Main Campus Dr, Suite 200
Raleigh, NC 27606

ATTACHMENT A WORK PLAN

In accordance with the Cooperative Service Agreement between the County, WDNR and the United States Department of Agriculture (USDA), Animal and Plant Health Inspection Service (APHIS), Wildlife Services (WS), this Work Plan sets forth the objectives, activities and budget of this project during the period of this agreement.

Introduction

The U.S. Department of Agriculture (USDA) is authorized to protect American agriculture and other resources from damage associated with wildlife. Wildlife Services activities are conducted in cooperation with other Federal, State, and local agencies, private organizations and individuals.

The APHIS-WS program uses an Integrated Wildlife Damage Management (IWDM) approach (sometimes referred to as IPM or "Integrated Pest Management") in which a series of methods may be used or recommended to reduce wildlife damage. These methods include the alteration of cultural practices as well as habitat and behavioral modification to prevent damage. However, controlling wildlife damage may require that the offending animal(s) are killed or that the populations of the offending species be reduced.

Purpose

Objectives and need for assistance: Agricultural producers need professional wildlife damage management assistance in identifying, abating, and assessing black bear, white-tailed deer, elk, cougar, Canada goose, wild turkey, and sandhill cranes damage. APHIS-WS's objective will be to provide that assistance.

Expected results or benefits: The benefits to be derived from a cooperative black bear, white-tailed deer, elk, cougar, Canada goose, wild turkey, and Sandhill cranes management program include timely availability of the necessary wildlife damage management expertise, technical assistance, loans of necessary abatement equipment, and crop/livestock damage appraisal services for producers experiencing conflicts with one of more of these species. The intended result will be wildlife damage relief.

Planned APHIS-WS Activities

1. Approach: The proposed wildlife damage management program will be comprised of education, extension, technical assistance, and operational efforts. When complaints occur, an evaluation of the situation will be made to determine what appropriate action should be taken. APHIS-WS will consider all applicable methods and combinations of techniques available to alleviate the conflict. APHIS-WS will recommend an integrated wildlife damage management approach which may consist of elements such as: changes in farming or livestock practices, loan of damage abatement equipment, installation of cost-shared permanent fences, WDNR issued shooting permits, and crop damage compensation (WDNR funded). Specific abatement measures to be considered are outlined in Attachment B.

2. **Resources Required:** Overall supervision and program direction will be provided by the APHIS-WS State Director. Immediate supervision and program direction will be provided by the APHIS-WS District Supervisor and/or Assistant District Supervisor. All County Wildlife Damage Abatement and Claims Program (WDACP) funds will be managed as an integral part of the APHIS-WS districts WDACP budget. Specific financial details are outlined in Financial Plan.
3. **Procurement:** Purchase of supplies, equipment, and miscellaneous needs including salaries will be made by APHIS-WS as outlined in the Financial Plan. All WDACP expenditures will be processed through APHIS-WS financial administrative systems (FMMI) and charged to the County WDACP account as outlined in the APHIS-WS District WDACP budget.
4. **Stipulations and Restrictions:** APHIS-WS activities under this cooperative effort will be limited to the State of Wisconsin. Techniques will be environmentally sound, safe, and effective. Wildlife damage management activities will be performed within the policy guidelines of APHIS-WS, the State of Wisconsin, and the County in compliance with applicable State and Federal regulations.
5. **Reports:** Upon request, APHIS-WS will provide an annual report to the County on APHIS-WS activities conducted under this Cooperative Agreement.

Effective Dates

This agreement shall become effective on January 1, 2024 and continue through December 31, 2028 unless otherwise modified or terminated as described in ARTICLE 12.

ATTACHMENT B
WISCONSIN WILDLIFE DAMAGE ABATEMENT & CLAIMS PROGRAM (WDACP)
PLAN OF ADMINISTRATION
SAUK COUNTY

As confirmed in the County Board of Supervisor's Resolution No. 87-2013, the County request to participate in the Wildlife Damage Abatement and Claims Program (WDACP), established under s. 29.889, Stats., and s. NR 12 Wis. Adm. Code. This Plan of Administration (Plan) outlines the relationships and duties of the County, the Wisconsin Department of Natural Resources (WDNR), and the United States Department of Agriculture, Animal Plant Health Inspection Services, Wildlife Services (APHIS-WS), herein called the parties. By submission of this Plan, the County agrees to fully comply with s. 29.889, Stats., s. NR 12, Wis. Adm. Code and the Wisconsin WDACP Technical and Field Manuals which are made a part of this Plan by reference.

1. Definitions: For the purposes of this Plan, the Parties accept the definitions found in s. 29.889(1) Stats. And s. NR 12.31 WI. Adm. Code. In addition, the Parties agree that:
 - a. "Improperly filed claim" means any wildlife damage claim received by WDNR which does not comply fully with all eligibility requirements of s. 29.889, Stats., s. NR. 12 Wis. Adm. Code or this Plan or procedures described in the WDACP Technical or Field Manual.
 - b. "Permanent fence contract" means any permanent fence contract written in accordance with the Wisconsin WDACP Technical Manual and designed to remain effective for a minimum of 15 years.
2. Level of Participation: The County agrees to administer the full WDACP.
3. Eligible Species: The County agrees to administer the WDACP with respect to the following wild animals: bear, cougar, white-tailed deer, elk, Canada goose, wild turkey, and Sandhill cranes * (**only become eligible for program benefits when a hunting season in Wisconsin has been established*).
4. Eligible Crops: The County agrees to provide WDACP services with respect to the following: damage to commercial seedlings or crops growing on agricultural lands, damage to crops that have been harvested for sale or further use but have not been removed from the agricultural land, damage to orchard trees or nursery stock, damage to livestock, or damage to apiaries.
5. Delegation of Responsibility:
 - a. The County, through an established committee or through a county designee shall provide Administration of the County WDACP pursuant to s. 29.889, Stats., s. NR 12, Wis. Adm. Code including approval of: annual budget requests, permanent fence contracts, crop prices, properly filed wildlife damage claims, shooting permit compliance waivers, and enrollee appeals, (if any).

- b. APHIS-WS shall provide the field management of the County WDACP, including hiring, training, and supervising staff, providing program services, records management, purchasing, and equipment inventory.

6. Budgeting:

a. APHIS-WS agrees to:

- i. Prepare a WDACP budget proposal for the following calendar year for County review and approval by October 31 (or as negotiated).
- ii. Not bind the County to the expenditures of funds exceeding their total County WDACP budget.
- iii. Keep administrative costs to a minimum, by billing WDACP expenses to each County on a quarterly basis.

b. The County agrees to:

- i. Provide an annual budget request to WDNR by November 1 (or as negotiated) for the following calendar year. All budget requests will include cost estimates for administration, abatement, wildlife damage claims, and an estimated number of claimants.
- ii. Prepare quarterly (or as negotiated) reimbursement request to WDNR for eligible WDACP expenditures.
- iii. Not bind WDNR for expenditures beyond the approved County Plan of Administration. The County may request additional funding by written amendment. It is understood that additional funding is not guaranteed and is subject to fund availability.
- iv. Unless otherwise agreed upon, submit advance abatement and administrative fund requests that are compliant with s. 29.889 and NR 12, after submitting a final reimbursement request for previous year for which WDACP participation was approved.

c. WDNR Agrees to:

- i. Review and approve, amend, or deny the annual budget request in accordance with s. 29.889, Stats., s. NR 12.32, Wis. Adm. Code, and advance funds under s. NR 12.34 (unless otherwise agreed upon), Wis. Adm. Code within 30 days of department approval of the annual budget estimate.
- ii. Review and approve, amend, or deny reimbursement requests in accordance with s. NR 12.34 and s. NR 12.35, Wis. Adm. Codes.

- iii. Review and act on properly filed wildlife damage claim requests no later than June 1 following the calendar year in which damage occurred.
- iv. If eligible wildlife damage claims are submitted late by the County, WDNR may accept and process the claims if funds are available, and the payment will not adversely affect claimants for the proceeding calendar year claim payments.
- v. If statewide approved wildlife damage claims exceed available funds, claims shall be paid on a prorated basis as established in s. NR 12.37 (3) Wis. Adm. Code.

d. The Parties mutually recognize and agree:

- i. WDNR may not bind the State of Wisconsin to pay costs beyond the amount appropriated for the WDACP.
- ii. WDNR may defer until after July 1, the payment of County reimbursement requests beyond the initial 25% funds advancement.
- iii. The County and WDNR shall not restrict APHIS-WS to line items estimates in the WDACP budget if total expenditures, per expense category of abatement or administration, do not exceed the total budgeted amount approved by the County and WDNR.
- iv. The County WDACP budget may be spent in its entirety. Any unspent funds will remain with the WDNR WDACP program.
- v. Supplies, materials, and equipment will be purchased with WDACP funds. If this Agreement is terminated by any of the Parties, items purchased will be transferred within the WDACP for use or proceeds of items shall remain with the WDACP or returned for reimbursement if possible.
- vi. WDNR will not reimburse the cost of abatement measures unless those measures were prescribed and implemented according to the Wisconsin WDACP Technical Manual.
- vii. WDNR will not make payment for any wildlife damage claim which does not comply with all eligible requirements of s. 29.889, Stats., s. NR 12, Wis. Adm. Code, or this Plan of Administration.

7. Recordkeeping:

a. APHIS-WS and the County agree to:

- i. Maintain record keeping practices and procedures that confirm to accounting practices directed by the WDNR and in compliance with s. NR 12, Wis. Adm. Code.

- ii. Make all records and files relating to the WDACP available to the other Parties, upon request.
 - iii. Send copies of any WDACP documentation to the other Parties, upon request.
 - iv. Use WDNR authorized databases and forms for billing and reporting.
- b. APHIS-WS agrees to: Maintain separate enrollee files and keep records of all abatement recommendations, appraisals, and all WDACP related interactions with each enrollee.
 - c. The County agrees to: Direct all billings to WDNR, Wildlife Damage Specialist
 - d. WDNR may: Conduct periodic audits of County record keeping procedures and prepare a written report to the County.
 - e. The Parties recognize and agree: All WDACP records are subject to the Wisconsin Open Records Law s.16.61, Stats. Any WDACP records requested will be provided by the County, WDNR, and/or APHIS-WS, as applicable.

8. Abatement Measures:

- a. The parties mutually recognize and agree that:
 - i. WDNR shall maintain web pages detailing the WDACP and describing how services may be requested.
 - ii. All enrollees shall be required to have a signed enrollment form on file to meet the hunting requirements in s. 29.889 (7m), Stats., s. NR 12.36, Wis. Adm. Code prior to receiving WDACP assistance.
 - iii. All abatement measures recommended to alleviate wildlife damage shall conform to the procedures and priorities found in the Wisconsin WDACP Technical Manual and will be accepted by the County as complete and appropriate "recommended abatement". Other abatement measures may be used if approved in advance, in writing, by WDNR.
 - iv. In the event equipment loaned by APHIS-WS to an enrollee is damaged beyond normal wear and tear, the enrollee/owner shall be billed for parts and labor to repair the damaged equipment, or if repair costs exceed the value of the equipment, the enrollee will be billed for the replacement of the equipment. APHIS-WS agrees to invoice the enrollee for these costs through a separate Cooperative Service Agreement and deposit the proceeds in the County's WDACP account. If the enrollee refuses to pay:
 - 1. The County shall direct APHIS-WS to refuse abatement services until payment is made (consequently the enrollee would be ineligible for a wildlife damage claim) or

2. The County shall take a reasonable legal action to recover the loss of WDACP materials and/or equipment and deposit the proceeds in the County's WDACP account.
- v. Permanent fences for white-tailed deer or elk abatement shall only be recommended subject to the priorities and conditions set forth in the Wisconsin WDACP Technical Manual or as directed by WDNR.
1. A WDACP enrollee for which a permanent fence has been recommended and approved will be required to agree to the design of the fence in advance of letting the project for bid. The enrollee will be responsible for all materials and/or installation costs in excess of the low bid amount if the enrollee requests changes in the fence design subsequent to letting the bids for said fence.
 2. A permanent fence contract shall be signed by the enrollee/landowner, the County, WDNR, and APHIS-WS. This contract shall be registered with the appropriate County Register of Deeds.
 3. All aspects of permanent fencing projects shall comply with requirements in the Wisconsin WDACP Technical Manual.
 4. All permanent fences must be approved by the County and approved in writing by the WDNR prior to soliciting and awarding bids for materials and construction of the fence.
 5. All permanent fences that exceed the specification found in the Wisconsin WDACP Technical Manual must have prior written approval from WDNR.
 6. The County will pay the WDACP's 75% obligation for permanent high-tensile woven wire projects approved by the WDNR, when APHIS-WS has determined that the WDACP requirements for materials and construction have been met.
 7. An initial fence inspection will be completed by APHIS-WS and all information will be entered into the WDNR database including a copy of the registered permanent fence contract.
 8. APHIS-WS shall conduct inspections a minimum of once annually of all permanent fences cost-shared through the WDACP to ensure fence contract compliance. All inspection records will be annually recorded in the WDACP database.
 9. A penalty fee (*fee to be determined*) may be charged to the enrollee if the fence has been awarded and the enrollee withdraws or elects to NOT build the approved fence.

10. Enrollees will be denied additional full program WDACP assistance if a permanent fence has been recommended as the primary abatement and the enrollee refuses the fence. For as long as a permanent fence is the primary recommended abatement for that enrollee full WDACP program assistance (any abatement and/or claims) will be denied in all subsequent years until a fence is erected. NOTE: Enrollee may remain eligible for Act 82 permits, as long as all conditions for Act 82 enrollment have been met.
 11. The contractor shall be liable for the payment of penalties to the WDACP accruing in the amount described in the permanent fence Bid Request, in the event the Contractor fails to meet the delivery and/or installation schedules as specified. Penalties, if applicable, shall be deducted from the payment that is owed to the contractor under the terms of the Bid and its associated bid conditions.
 12. APHIS-WS will prepare all Satisfaction of Contract paperwork and record this paperwork with the appropriate county Register of Deeds, when the fence has reached the end of its 15-year term and/or when the contract has been otherwise satisfied (i.e., enrollee has provided payment to end the contract prior to the end of the 15-year term according to the pay back clause of the clause of the register permanent fence contract).
- vi. Enrollees shall be encouraged to integrate sound conservation practices with their normal agricultural practices.
 - vii. The County, in accordance with s. NR 12.35(4) Wis. Adm. Code will not administer abatement measures to persons not cooperating with County personnel or the County's agents responsible for administering the County's WDACP. Abusive language, behavior, threats of violence, or otherwise will be considered a failure on the part of the enrollee to cooperate. This condition of administration will be provided by the County or its agent, in writing to program enrollees.
- b. WDNR and APHIS-WS agree to: Provide current information, as available, on the effectiveness of the above abatement measures and/or changes to the Wisconsin WDACP Technical Manual.
9. Wildlife Damage Claims:
- a. APHIS-WS agrees to:
 - i. Advise the County WDACP enrollees in writing procedures and requirements for submitting a wildlife damage claim, and all other WDACP eligibility requirements through the use of the current program Farmers Fact sheet and/or other informational materials.

- ii. Require that potential claimants specify the location of damage, crop(s) being damaged, species of wildlife causing damage, and the date damage first occurred with a written, telephone, or personal consultation.
- iii. Require that enrollees have signed enrollment form(s) (WDNR form) on file to meet the hunting requirements in s. 29.889 (7M), Stats. And s. NR 12.36(2) Wis. Adm. Code.
- iv. Inspect reported damage to verify eligibility requirement and recommend abatement measures.
- v. Determine the amount of huntable land and the applicable number of hunters for each enrollee in accordance with s. NR 12.31(4) or (4e), Wis Adm. Code, notify each enrollee of the requirement to allow open public hunting or managed hunting access (at least 2 hunters per 40 acres of land suitable for hunting). Land suitable for hunting all eligible species other than deer and elk shall be determined in a manner consistent with s. NR 12.31(4e) Wis. Adm. Code. Participants who only receive a deer shooting permit and waive any eligibility to receive a wildlife damage claim payment or other WDACP program assistance, are exempt from the public hunting requirement (Act 82 enrollment), (s. NR 12.36 (1m) Wis. Adm. Code). Participants who receive abatement only on leased land properties for bear damages to apiaries are exempt from the public hunting requirements as defined in s. 29.889 (7m), Stats.
- vi. Prepare maps of properties enrolled in the WDACP that are required to open to the public for hunting the species causing damage. Maps must detail the acres enrolled, Township, Range, Section number(s), identifying owned and leased land properties enrolled, and the enrollee's contract information. APHIS-WS will obtain approval from the enrollee to assure that the map includes complete and accurate information regarding all properties enrolled. APHIS-WS staff will enter a copy of the map into the WDNR database, per the WDNR mapping guidelines.
- vii. Notify WDACP enrollees that any site will be ineligible if they fail to:
 - 1. Control hunting access on all contiguous land under the same ownership and control, except in situations involving apiaries on land not controlled by the enrollee as defined in s. 29.889 (7m), Stats.
 - 2. Allow public hunting for the species causing damage (two options available)
 - a. Open public hunting (OPH)
 - b. Managed Hunting Access (MHA) – the presence of 2 hunters per 40 acres of land suitable for hunting.

3. Sign the appropriate enrollment form(s) including obtaining landowner consent for enrollment of leased properties in a timely manner.
 4. File a wildlife damage complaint with APHIS-WS within 14 days of first damage each year.
 5. Follow APHIS-WS's recommended abatement according to the WDACP Technical Manual list of approved methods.
 6. Request an appraisal for each crop and/or cutting from APHIS-WS orally or in writing at least 10 days prior to the harvest of crops, and delay harvest of said crops for a period of up to 10 days to allow APHIS-WS time to appraise the unharvested crops, or until the appraisal is completed.
 7. Notify APHIS-WS if they charge any fees for hunting or hunting access, or any other activity that includes hunting for the species causing the damage.
- viii. Inspect the crop or individual fields identified by the enrollee, prior to harvest, and access the eligible wildlife damage and prepare a wildlife damage claim.
 - ix. Retain the claim until the end of the calendar year or end of the state harvest season for the enrolled species, whichever is later, to determine the enrollee's compliance with the WDACP requirements.
 - x. Establish, as described below, uniform unit prices for eligible crops and calculated the value of the eligible wildlife damage claims (see Mutual Agreement between all parties 4b).
 - xi. Ensure that crop damage resulting from improper crop management, compromised growing conditions and weather, or wildlife other than the covered species, is not included in the official crop damage appraisals conducted by APHIS-WS prior to preparation of the enrollee's official wildlife damage claim.
 - xii. Summarize and prepare the necessary WDNR forms for all wildlife damage claims for review by the County prior to the succeeding March 1st. Upon approval by the County, claims will be submitted to the WDNR, unless otherwise negotiated by the succeeding March 1st.
 - xiii. Notify, in writing, any enrollee whose wildlife damage claim has been rejected and provided the reason for the rejection, as well as the appropriate appeal procedures.

b. The County agrees to:

- i. Review and approve all properly filed wildlife damage claims.
 - ii. Establish crop prices in accordance with the WDACP Technical Manual or approve prices as recommended by APHIS-WS.
 - iii. Deny all wildlife damage claims for a crop site where an invalid enrollment form has been signed by the enrollee and filed with APHIS-WS
 - iv. Deny all wildlife damage claims where APHIS-WS did not receive a complaint within 14 days of first damage.
 - v. Deny all wildlife damage claims for crop sites where APHIS-WS abatement recommendations were not followed.
 - vi. Deny all wildlife damage claims for crops that were harvested before an appraisal request was made to APHIS-WS or before an appraisal was completed (within a 10-day period from notification of harvest).
 - vii. Deny all wildlife damage claims on row crops for damage occurring to these crops during a particular growing season after 90 percent of the County's harvest for this crop has been completed, as required by s. NR 12.37(1)(c), Wis. Adm. Code. The County may consult with the local FSA and UW extension offices for assistance in making the 90 percent determination (if desired).
 - viii. Deny all wildlife damage claims if an enrollee is not compliant with the prescribed harvest objective if issued a deer damage shooting permit, and the consulting group consisting of the County, the damage specialist and WDNR, does not collectively recommend an exemption to the harvest objective requirement.
 - ix. The County shall take reasonable legal action to recover claim payments made on the basis of fraudulent or negligent claims or statements.
- c. WDNR agrees to: Accept the amount of wildlife damage for all properly filed wildlife damage claims approved by the County as final for purposes of review.
- d. It is mutually agreed by the County, APHIS-WS, and WDNR that:
- i. Damage assessment for compensation will be performed by APHIS-WS staff in accordance with the Wisconsin WDACP Technical Manual and Field Handbook and will be accepted by the County as complete and accurate "assessed damage".
 - ii. Compensation prices will be developed by APHIS-WS using information from UW Extension and/or local marketplace data and proposed to the County for approval, each year. Such prices will be established according to procedures set forth in the Wisconsin WDACP Technical Manual. Such

prices will be applied to all individuals with eligible wildlife damage to those crops throughout the County.

- iii. Public complaints (abatement compliance, fraud, etc.) must be written and received by APHIS-WS by December 31st, to be given consideration in the wildlife damage claims determination process. Hunting access denial complaints shall be written and received by APHIS-WS within 10 days of hunting access denial to be given consideration in the wildlife damage claims determination process, as described in the WDACP Technical Manual.
- iv. The County will not administer a damage appraisal and/or claim to persons not cooperating with County personnel or its agent responsible for administering the County's Wildlife Damage Abatement and Claims Program. Abusive language, behavior, threats of violence, or otherwise will be considered a failure on the part of the enrollee to cooperate. This condition of administration will be provided by the county or its agent, in writing to program enrollees.
- v. As required by s. NR 12.37(4)(a) 4.b., Wis. Adm. Code as part of the claims approval process, if an enrollee who has been issued a shooting permit is found not to be compliant with the harvest objective prescribed under his/her permit under s. NR 12.163(2)(a), Wisc. Adm. Code, then the County, its agent, and the department shall consult before making a collective recommendation to grant an exemption to the harvest objective requirement. This group shall review the evidence if there is consensus that an exemption is warranted, they shall recommend that the County designated committee charged with the approval of such damage claims, grant approval of the damage claim for the year in which the permit was issued. Compelling evidence that shall be used is detailed in s. NR 12.163(2)(b)2., Wis. Adm. Code.

10. Charges: The terms of this Agreement may be changed by written amendment approved by all Parties.

11. Termination:

- a. The County may terminate participation in the WDACP upon notifying WDNR in writing thirty (30) days prior to termination.
- b. WDNR shall terminate a County Plan of Administration if the County does not comply with all conditions of s. 29.889, Stats., s. NR 12, Wis. Adm. Code, this Plan of Administration, the Wisconsin WDACP Technical Manual, or fails to properly report costs of the program or claims.
- c. WDNR agrees to reimburse the County for WDACP costs incurred and determined proper by DNR under this Plan of Administration prior to the effective date of termination.

- d. That upon termination of the Agreement, the County shall reimburse APHIS-WS for all County WDACP obligations created by APHIS-WS as a result of this Agreement and not previously reimbursed, to the limits of the County WDACP budget.
- e. In the event that the County chooses to exercise its right to overrule APHIS-WS on a particular case under the general policy provision, APHIS-WS reserves the right to withdraw administrative and/or fiscal support of that case. Either action may occur without termination of this Agreement.

12. Length of Effect: This Plan shall remain in effect until December 31, 2028, unless otherwise changed or terminated as described in Article 12 and sections 10 and 11.

**ATTACHMENT C
FINANCIAL PLAN**

Annual Budgets will be completed by APHIS-WS representative, approved by all Parties, and signed by County, WDNR, and APHIS-WS representatives.

Financial Point of Contact/Billing Address:

County representative Name, Address,
Phone Number, Email

Melissa Schlupp
West Square Building, Room 248
505 Broadway
Baraboo, WI 53913
608-355-3245
Melissa.schlupp@saukcountywi.gov

APHIS-WS State Office Name, Address, Phone
Number, Email

Tina Stott, Budget Analyst
USDA, APHIS, WS

732 Lois Drive
Sun Prairie, WI 53590
608-478-3742
Tina.stott@usda.gov

RESOLUTION # 96-2023

Resolution Authorizing to contract with TelCom Construction, LLC for the relocation of Sauk County owned fiber optic cable at the intersection of CTH BD and N. Reedsburg Rd.; and Amend the 2023 Building Services Capital Outlay budget

Resolution offered by the Property Committee and Finance Committee

BACKGROUND: Sauk County owns and maintains over 196 miles of fiber optic network cable and conduit throughout the county. CTH BD and N. Reedsburg Rd is being reconstructed into a roundabout during the 2024 road construction season. It is the responsibility of the owner of the utility to re-route utilities at the owner's expense to avoid a construction conflict. The current Sauk County Facilities are in conflict with the new roundabout construction plans. Approximately 2,534' of new duct and new fiber optic cable will be installed during the re-route of County Facilities. Splicing of the new fiber will be completed by a county contractor. The non-budgeted project came in at a not exceed cost of \$66,500. Design/Engineering (\$10,500.00), labor and materials for conduit & fiber (\$43,00.00), splicing (8,000), & materials purchased by county (\$5,000). Building Services is asking to also amend the current 2023 Building Services Capital Outlay budget to add \$66,500 of general fund dollars to cover the cost of the project.

THEREFORE, BE IT RESOLVED THAT, the Sauk County Board of Supervisors, met in regular session, hereby authorizes the County Administrator to sign a contract with Telcom Construction to provide the labor at a cost of \$43,000 to relocate current Sauk County Fiber to a location that is not within conflict of the proposed roundabout plan at a cost of \$66,500.

Approved for presentation to the County Board by the Property Committee & Finance Committee, this 6th day of December 2023.

Consent Agenda Item: [] YES [X] NO

Fiscal Impact: [] None [] Budgeted Expenditure [X] Not Budgeted

Vote Required: Majority = _____ 2/3 Majority = X 3/4 Majority = _____

The County Board has the legal authority to adopt: Yes X No _____ as reviewed by the Corporation Counsel, Byrd, Date: 12.12.2023

Offered and passage moved by Property Committee:

Carl Gruber
Carl Gruber

Mark "Smooth" Dettler
Mark "Smooth" Dettler

Joel Chrisler

Robert Spencer
James Astle
Jim Astle

57 **Finance Committee:**

58 
 59 Martin F. Kueger

60 
 61 Lynn Eberl

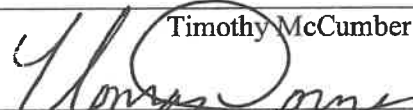
62 
 63 Timothy McCumber

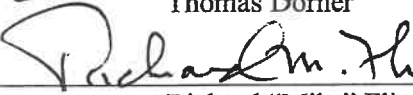
64 
 65 Thomas Dorner

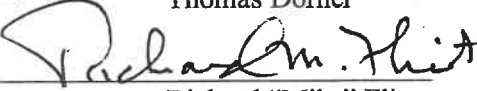
66 
 67 Richard "Mike" Flint

68 **Fiscal Note:** The North Reedsburg Road fiber re-route project will begin in 2023 and be completed in
 69 2024. \$66,500 of general fund balance will be added to the Building Services capital projects 2023
 70 budget with unspent funds be carried forward into 2024 to complete the project.

71 **MIS Note:** A network wide outage will occur when the new fiber is spliced into the existing fiber

72

Company	Base bid for relocation of approx. 2,534' of new duct and fiber	Design/Engineering	Splicing	Sauk County Materials	Project Total
Key Tower LLC	\$ 116,795	\$ 10,500	\$ 8,000	\$ 5,000	\$ 140,295
TelCom Construction LLC	\$ 43,000	\$ 10,500	\$ 8,000	\$ 5,000	\$ 66,500
J&R Underground	\$ 70,000	\$ 10,500	\$ 8,000	\$ 5,000	\$ 93,500
InterCon Construction Inc	\$ 52,655	\$ 10,500	\$ 8,000	\$ 5,000	\$ 76,155
Holtger Bros. Inc	\$ 84,840	\$ 10,500	\$ 8,000	\$ 5,000	\$ 108,340

73

74

75

76

77

78

79

RESOLUTION # 97 - 2023

Resolution to Approve the Liability, Property, and Workers Compensation Coverage, Insurance, Carrier, and Premiums for Sauk County

Resolution offered by the Personnel and Insurance Committee

Resolved by the Board of Supervisors of Sauk County, Wisconsin:

BACKGROUND: The Personnel and Insurance Committee determined Wisconsin County Mutual Insurance Company (WCMIC) provides the most complete coverage for all lines of insurance for 2024, including liability, property, and workers compensation. Therefore, the Personnel and Insurance Committee recommends Wisconsin County Mutual Insurance Corporation (WCMIC) as the most cost-effective proposal for liability, property, and self-insured workers compensation coverage for 2024 as outlined below. *

*WCMIC provides a significant discount of \$41,998 for consolidating the liability, property, and workers compensation coverages for 2024.

NOW, THEREFORE, BE IT RESOLVED, the Personnel and Insurance Committee has reviewed the 2024 premiums for general liability, nursing home liability/professional liability and excess liability (umbrella) coverage for Sauk County from the Wisconsin County Mutual Insurance Corporation (WCMIC) and recommends the following as being in the best interest of Sauk County:

Public Entity General and Auto Liability	
<u>General and Automobile Liability</u>	\$ 385,637
\$10,000 deductible	
\$75,000 aggregate	
<u>Uninsured Motorists</u>	\$ included
\$10,000 occurrence	
\$25,000 person	
\$50,000 occurrence	
Cyber Enhancement	\$ included
Special Exposures (Airport and Nursing Home)	\$ included
Position Schedule Bond	\$ 2,510
Crime	\$ 7,899
Health Care Center (Nursing Home) Liability Endorsement	
<u>Personal Injury Coverage</u>	
Health Care Center Liability Endorsement	\$ 14,222
\$1,000,000/ Occurrence	
Professional Liability	
\$3,000,000/ Aggregate	
TOTAL WCMIC LIABILITY PREMIUM (Subject to Escrow Adjustment) \$410,268	

BE IT FURTHER RESOLVED, the Personnel and Insurance Committee has reviewed the renewal for the 2024 premiums for property insurance for Sauk County and recommends the following coverage for Sauk County from Wisconsin County Mutual Insurance Corporation (WCMIC) and recommends the following as being in the best interest of the County:

52
53
54
55
56
57
58
59
60
61
62
63
64
65
66
67
68
69
70
71
72
73
74
75
76
77
78
79
80
81
82
83
84
85
86
87
88
89
90
91
92
93
94
95
96
97
98
99
100
101
102

COVERAGE	DEDUCTIBLE	PREMIUM
Buildings, Contents, Property in Open Contractors Equipment	\$25,000 \$5,000	\$ 94,743 \$ included
Equipment Breakdown	\$25,000	\$ 5,378
Special Use Animal	\$1,000	\$ included
Automobile Physical Damage Comp/Collision	\$1,000/\$5,000	\$ 70,257
TOTAL PREMIUM TO WCMIC FOR PROPERTY		\$170,378

BE IT FURTHER RESOLVED, the Personnel and Insurance Committee has reviewed the renewal for the 2024 premium for Workers Compensation coverage for Sauk County and recommends that the following self-insurance proposal by Wisconsin County Mutual Insurance Corporation (WCMIC) as being in the best interest of Sauk County.

COVERAGE	LIMITS	PREMIUM
Accident	\$ 100,000	\$ included
Disease Exposure	\$ 100,000	\$ included
Maximum Employer Liability	\$ 600,000	
TOTAL PREMIUM TO WCMIC FOR SELF-INSURANCE		\$159,047

BE IT FURTHER RESOLVED, by the Sauk County Board of Supervisors in regular session meeting, that the above insurance coverage, carrier, and premiums be, and hereby are, adopted for the policy period of January 1, 2024, through December 31, 2024.

Approved for presentation to the County Board by the Personnel and Insurance Committee, this 19th day of December 2023.

Consent Agenda Item: YES NO

Fiscal Impact: None Budgeted Expenditure Not Budgeted

Vote Required: Majority = X 2/3 Majority = _____ 3/4 Majority = _____

The County Board has the legal authority to adopt: Yes X No _____ as reviewed by the Corporation Counsel, [Signature], Date: 12.14.2023.

Offered and passage moved by:

Supervisor Carl Gruber Aye Nay Abstain Absent

Supervisor Terry Spencer Aye Nay Abstain Absent

103
104
105
106
107
108
109
110
111
112
113
114
115
116
117
118
119
120
121
122
123

Supervisor Peter Kinsman Aye Nay Abstain Absent

Supervisor Robert Prosser Aye Nay Abstain Absent

Supervisor Jake Roxen Aye Nay Abstain Absent

Fiscal / MIS Note: The above premium costs are included in the 2024 budget. Auto Liability is budgeted as a separate line item in various departments, in accordance with vehicle inventory values. General Liability is charged back to certain departments that can receive additional outside funding with an allocation basis of relative expenditures. Workers Compensation is allocated to departments according to wages budgeted and risk categories. Property and Equipment Insurance is allocated to the departments based on property and equipment assigned to each department. Health Care Center Professional Liability and Personal Injury Extension Endorsement are allocated to the Sauk County Health Care Center.



MIS Note: No information systems impact.

RESOLUTION # 98-2023

Resolution to Expand the Long-Term Care Continuum in Sauk County

Resolution offered by the Property Committee

Resolved by the Board of Supervisors of Sauk County, Wisconsin:

BACKGROUND: In August of 2010, Keefe & Associates studied the potential long-term care continuum for the county. It laid out a strategy for potentially adding Assisted Living to the nursing home Reedsburg campus. Until 2018, multiple follow up studies reported the market was continuously oversaturated until a report by Wipfli LLC in 2018.

It is highly unlikely Sauk County will be able to expand the continuum without increasing the amount of taxpayer support the existing facility already requires. For the years 2018 through the end of 2024 the county will have spent more than \$17 million in sales and property tax revenues or an average of \$2.44 million per year.

There is no statutory requirement for the county to own or maintain a nursing home. The monies allocated to support the nursing home are better spent meeting the needs of our aging population through statutorily required programs that benefit residents throughout Sauk County rather than a facility that primarily serves only the Reedsburg market.

This resolution proposes marketing the nursing home and incentivizing a developer to build a long-term care facility and preserve the 82 bed licenses in the county.

NOW THEREFORE, BE IT RESOLVED, by the Sauk County Board of Supervisors that a Request for Proposals marketing the Sauk County Nursing Home be issued with the following conditions:

- The bed licenses cannot be sold or transferred outside of Sauk County subject to severe penalties as established in the terms of sale.
- The county reserves the first right of refusal not to exceed the sale price should the owner decide to sell the property.
- Preferential consideration may be given to a local (Sauk County based) buyer.
- The sale price shall not be less than the value of the outstanding bond payments.
- The remaining 31.7 acres of land may also be used to incentivize the construction of an assisted living or comparable long-term care facility.
- Any amount over the value of the outstanding bond payments may be used to incentivize construction of an assisted living or comparable long-term care facility.
- The potential buyer shall demonstrate a history of 5-star ratings in the senior health care industry.
- The potential buyer shall retain existing staff subject to job performance.
- The Board of Supervisors shall approve all final contracts.

BE IT FURTHER RESOLVED, that the existing nursing home staff will have first priority when filling new or vacant positions elsewhere in the county based upon qualifications and past job performance; and,

50
51
52
53
54
55
56
57
58
59
60
61
62
63
64
65
66
67
68
69
70
71
72
73
74
75
76
77
78
79
80
81
82
83
84
85
86
87
88
89
90
91
92
93
94

BE IT FURTHER RESOLVED, the county board shall encumber the remaining 31.7 acres of adjoining land for a period not to exceed 10 years if a long-term care facility is not acquired for the site; and,

BE IT FURTHER RESOLVED, that if the property is sold, the County Administrator shall present a plan to Finance for final consideration by the County Board of any unused sales tax or tax levy from the 2024 proposed budget with allocations being prioritized for the Aging and Disability Resource Center (ADRC), Veteran’s Services, Human Services and Public Health as well as county staff salaries.

Approved for presentation to the County Board by the Property Committee, this ____ day of _____, 2023

Consent Agenda Item: [] YES [] NO

Fiscal Impact: None [] Budgeted Expenditure [] Not Budgeted

Vote Required: Majority = X 2/3 Majority = _____ 3/4 Majority = _____

The County Board has the legal authority to adopt: Yes X No _____ as reviewed by the Corporation Counsel, Boyd, Date: 12.12.2023.

Offered and passage moved by:

Smooth Deter Aye Nay Abstain Absent
Mark "Smooth" Detter

Carl Gruber Aye Nay Abstain Absent
Carl Gruber

Joel Chrisler Aye Nay Abstain Absent

Robert Spencer Aye Nay Abstain Absent

James Astle Aye Nay Abstain Absent
James Astle

Fiscal Note: Fiscal note: The Health Care Center has outstanding general obligation bond debt payable through 2027 totaling \$4,464,565 and the 2024 budgeted county levy allocated was \$788,087.

Health Care Center	YEAR				
	2024	2025	2026	2027	TOTAL
Principal Redemption	\$ 995,000	\$ 1,020,000	\$ 1,050,000	\$ 1,085,000	\$ 4,150,000
Interest Expense/ Premium Amortization	124,990	94,952	64,127	30,496	314,565
Total Debt Expense	\$ 1,119,990	\$ 1,114,952	\$ 1,114,127	\$ 1,115,496	\$ 4,464,565
2024 Budgeted Levy	788,087	TBD*	TBD*	TBD*	TBD*
	\$ 1,908,077	TBD*	TBD*	TBD*	TBD*

*TBD or To Be Determined

95
96
97
98
99
100
101
102

MIS Note: MIS Note: Based upon MIS internal reporting, technology support for the Health Care Center accounts for roughly 5% of the total MIS support hours. Infrastructure costs, not already included in the Health Care Center's annual budget, amount to approximately \$5,000 per year.

2024 - 2026 RULES OF THE COUNTY BOARD

RULE I – Organization

- A. As provided by statute, the Sauk County Board of Supervisors (“Board”) shall organize on the third Tuesday of April in even numbered years. Regular and special meetings of the Board shall be held and conducted in accordance with the provisions of Wis. Stat. § 59.11. The Board shall hold an annual meeting on the Tuesday after the second Monday of November in each year for the purpose of transacting business and the adoption of the budget. When the day of the meeting falls on November 11, the meeting shall be held on the next succeeding day.
- B. The Chair of the County Board (“Chair”), Vice-Chair, and 2nd Vice-Chair shall be elected biennially by the Board at the April meeting in even-numbered years. A majority vote of the total elected Supervisors is required to elect the Chair, Vice-Chair and 2nd Vice Chair (e.g. 31 districts in Sauk County, 16 votes required regardless of number of Supervisors in attendance at meeting). Furthermore, any Supervisor may request removal of the Chair or Vice-Chair and new elections for a new Chair, Vice-Chair or both under item 13 of the regular Board meeting agenda, provided such request is placed with the County Clerk and County Administrator pursuant to the provisions of III. U. Such officers shall take office upon election. The meeting shall be chaired by the Corporation Counsel until a new Chair is elected. No Supervisor may be elected as Chair for more than three (3) consecutive terms.
- C. In addition to presiding at meetings, the supervisor elected Chair by the Board, pursuant to Rule I.B., shall upon election, assume all the responsibilities and perform all duties required of the Chair, pursuant to applicable State Statutes and these Rules, until the Board elects a successor.
- D. In case of the absence or inability of the Chair for any meeting, the Vice-Chair shall perform the duties of the Chair. In case of the absence or inability of both the Chair and Vice-Chair for any meeting, the 2nd Vice -Chair shall perform the duties of the Chair. In the absence of the Chair, Vice-Chair and 2nd Vice -chair, the members shall choose a temporary Chair by a majority vote of the members present. In the case of the permanent absence or inability of the Chair, the Vice-Chair shall become Chair, and a new Vice-Chair shall be elected by the Board.
- E. The Chair is authorized to attend meetings and conferences on matters related to county government and may direct the attendance of the Vice-Chair or some other members of the Board, either in place of the Chair, or along with the Chair, however per diem. shall not be payable unless authorized in accordance with Rule II, E. The Chair shall serve as the County’s voting delegate at the Annual Convention of the Wisconsin Counties Association. The Chair shall serve on the following: Madison Area Technical College Appointment Board, Western Wisconsin Technical College District Board, and WIRED Leadership Caucus.

If a vacancy occurs on the Board, the procedures set forth Wis. Stat. s. 59.10(3)(e) shall govern in filling said vacancy. A supervisor filling a vacancy shall not automatically be assigned to the same committees as his or her predecessor in office but may request particular assignments. The chair shall have the option of removing or replacing any or all committee assignments for a replacement supervisor including moving a minimal number of supervisors to different committees if it benefits the county. Reassignment of supervisors requires the express consent of each reassigned supervisor and approval by a majority of members voting on the reassignment. Replacement of a member of the Executive & Legislative Committee, shall require election by the Board.

- F. Supervisors appointed to special committees, boards, and commissions shall serve on those bodies only so long as they remain members of the Board unless a state statute or county ordinance provides otherwise. At the point in time that a supervisor is no longer a member of the Board, the position on the special committee, board, or commission shall be deemed vacant, and the Chair shall appoint a new individual, who must be a member of the Board, to fill the unexpired term on the body. A former supervisor may only fill a citizen member position on a special committee, board or commission if the former supervisor's continued service will result in no diminution of representation on the body by members of the Board.
- G. A secret ballot may be used by the Board or a committee but only to elect an officer of the Board or the committee. When written ballots are used, except for secret ballots, supervisors shall indicate their vote by placing their district number on the reverse side of the ballot. The first ballot shall be the nominating ballot, to be followed by succeeding formal ballots until a majority vote of the members present elects. Persons nominated may address the Board for up to 3 minutes. Only persons named on a nominating ballot shall be considered during a formal ballot. A nominee may withdraw themselves from the ballot at any time after the initial ballot.
- H. The standing committees shall be appointed by the Chair, in consultation with the Executive & Legislative Committee, subject to the approval of the Board. Committee appointments shall be presented for approval at the next meeting of the Board following the date of organization. The Executive & Legislative Committee shall meet at the call of the Chair as soon as practical after the organizational meeting to consult on committee appointments. After consultation, the new, tentative committees appointed by the Chair shall serve prior to approval by the Board during the period between the organizational meeting and the regular meeting in May, where consideration by the Board shall take place.

**RULE II – Members
Decorum**

- A. The Board aspires to encourage appropriate dress by board members that reflects the professionalism of the Board. Business casual or more formal attire is encouraged.
- B. All comments, debates and discussions shall be appropriate and to the point of the topic under discussion, and conducted in a manner that is civil, and respectful of all concerned.
- C. Unless conducting non-County Board business, Supervisors wishing to confer with a Department Head shall schedule an appointment in advance with that particular Department Head and a Supervisor shall not contact staff (non-department head) without first seeking permission from the Administrator or Department Head.
- D. A minimum of one day of education for members of the Board shall be set by the Chair, said day of education to be held every two years. Such education may be conducted through electronic means, including but not limited to videos and webinars. The Chair may set additional days of education for Board members, including one or more days for the purpose of clarifying budget procedures and upcoming budget analysis matters.

Compensation

- E. Supervisors shall be authorized up to a maximum of 90 days' compensation (at a per diem rate of \$90.00 for each day of attendance when the Board is in session and meeting, and

\$75.00 for other authorized service including committee meetings), plus mileage and reimbursement of authorized expenses, for committee work when attending committee meetings of which they are members, or as chair of a committee (or their designee) when attending a committee meeting of which they are not a member for the purpose of providing testimony on an issue. Authorized service includes service required by ordinance or resolution. The maximum limits established for committee work shall be in addition to the per diems and mileage supervisors are entitled to receive for attendance at meetings of the Board and exclusive of per diems paid by non-county boards or commissions where the payment of the per diem or mileage is not made from County funds. Reimbursement of expenses (such as mileage, parking, etc.) shall be allowed only if a request for payment is made on the form provided by the Accounting Department within three (3) months after the meeting or event date. Payment to County Board supervisors and other committee members shall be only via direct deposit.

- F. As provided by Wis. Stat. § 59.13(2), no supervisor shall be allowed pay for committee service while the Board is in session, but the Board may authorize payment of per diem, mileage and reimbursement for other expenses for attendance at any school, institute or meeting which the Board directs them to attend. Each standing committee is specifically authorized to send up to two (2) members to up to two (2) conventions (including conferences and other trainings) per County fiscal year. The convention cannot exceed three (3) days or be farther than three hundred (300) miles. All other requests require approval by a majority of the Board. Wis. Stat. § 59.13(2). In addition, all Supervisors are allowed to attend the Wisconsin Counties Association Annual Meeting with all registration fees to be paid for by the County. The Chair shall be able to attend National Association of Counties meeting with reimbursement for expenses incurred.
- G. Any increase in the number of days of committee work for which supervisors may be paid compensation and mileage in any year shall require approval by two-thirds vote of the members of the Board present, prior to payment. In addition to the above, the Chair shall receive compensation for performance of the duties of that office. The Chair is authorized to act as a member of all committees in an *ex officio* capacity, and per diem and mileage are eligible to be paid under this rule for attendance at all committee meetings attended by the Chair.
- H. The supervisor elected Chair shall be entitled to receive the compensation provided for the part-time position of Chair consisting of a salary of \$650 per month in addition to any other per diem and mileage entitlement available to other supervisors in accordance with Rule II. E., as provided by Sauk Co. Code § 35.03.
- I. All members of the Board who are to be reimbursed for committee work shall submit vouchers to the County Clerk on a monthly basis, to be placed on file with other current claims or accounts to be authorized for payment at regular Finance Committee meetings. Per diem and mileage paid Board members through any calendar year shall be compiled in the Accounting Department and presented to the Board prior to annual publication in March of the following year. Supervisors who "ride along" with other supervisors may not claim mileage.
- J. No current claim or account to be paid from funds previously appropriated for any item by the Board in the Budget shall be allowed, nor order passed whereby any money is paid out or expended, until said claim or account has been referred to the appropriate department committee and report made thereof as directed by said committee.

- K. All claims or accounts for disbursements made by any County official must be itemized and contain sufficient information to identify proper budget authorization.

Rule III – Meetings

General

- A. The Board shall meet regularly in the County Board Room on the third Tuesday of each month except as provided in Rule I.A. above. Regular meetings of the full Board shall commence at 6:00 P.M. Any vote to adjourn to a different time or place for convening a regular meeting shall require approval by two-thirds of the members present.
- B. A Special Meeting of the Board shall be held in accordance with the provisions set forth in 59.11 (2). A Supervisor may signify agreement to a request by email, delivered to the Clerk via County email from a Supervisor's official Sauk County email address to the Clerk's official email address. Furthermore, the Clerk may notice a Special Meeting by email. Personal email accounts, SMS or other electronic messages are not acceptable.
- C. The order of business of Board meetings shall be as stated on the agenda for each session. The agenda shall jointly be the responsibility of the Chair, the County Administrator and the County Clerk. The agenda shall be circulated to the Board not less than two business days before each meeting. Agenda amendments that comply with Open Meeting Law notice requirements are permitted after initial circulation.
- D. The format for the agenda at the April organizational meeting held in even-numbered years shall be as follows:
1. Call to order.
 2. Invocation and pledge of allegiance.
 3. Verification of credentials and roll call.
 4. Administration of oath of office.
 5. Adoption of agenda.
 6. Approval of the minutes of the previous meeting.
 7. Designation of official newspaper.
 8. Election of a Chair and, Vice Chair & 2nd Vice-Chair.

(Proceed in accordance with regular meeting agenda, see III.E. 6. through 15.)

- E. The format for the regular meeting agenda of the County Board shall be as follows:
1. Call to order.
 2. Roll call.
 3. Invocation and pledge of allegiance.
 4. Adoption of agenda.
 5. Approval of the minutes of previous meeting.
 6. General consent agenda items.
 7. Scheduled appearances included on the agenda.
 8. Public comment with each speaker limited to no more than three minutes.
 9. Communications.
 10. Appointments.
 11. Bills.
 12. Claims.

13. Elections.
14. Proclamations.
15. Reports.
16. Unfinished business.
17. New business.
18. Referrals.
19. New agenda items (no discussion). Submit in writing or by email new business items to the County Administrator as soon as possible for Rule III.U. committee referral or addition to the Board agenda.
20. Adjournment.

F. It is declared to be the policy of Sauk County that the public is entitled to the fullest and most complete information regarding the affairs of County government as is compatible with the conduct of County affairs and the transaction of County business. Wis. Stat. §§ 19.80 to 19.98 are to be complied with by all members at all meetings of public nature. The Board and its committees shall "sit with open doors," and timely notification of all public meetings, time, date, place and subject matter shall be given, including the specifics for any contemplated closed session.

Procedure

- G. The Chair shall preserve order and decorum. The Chair may speak to points of order in preference to other members, and shall recite questions of order subject to an appeal to the Board by any two members, on which appeal no member shall speak more than once, unless by leave of the Board. He or she shall vote on all roll calls, except upon appeals from his or her own decision. The Chair may NOT participate in debate or discussion unless he or she steps down from the Chair and assumes their regular seat (the Vice-Chair would then run the meeting) then following the same rules as any other Supervisor.
- H. The Chair shall announce items as they arise on the agenda. With respect to a resolution or ordinance, the Chair shall ask if a member wishes to make a motion, and upon a motion, if there is a second. Upon a motion and second, the Chair, or the Clerk, shall state the question on the motion, identifying the resolution or ordinance by its title and number, and reading the resolution in full. If the text of the resolution or ordinance has been distributed to members in advance, the chair may state the question without reading it in full, instead identifying the resolution by its designated title and number, by saying: It is moved and seconded to adopt the resolution relating to . . . , as printed." Any Supervisor has the right to have the motion or resolution read. After the question has been stated, the Chair shall call upon the maker of the motion who may defer to the chair of the appropriate committee, or an appropriate County staff person, for any statement or explanation.
- I. In presenting business or debate, members shall address the Chair, be recognized, and when in order, proceed without any interruption. Debate and discussion should be limited to the agenda item under discussion. Discussion is intended to provide clarity on a given topic. In all cases, personalities are prohibited and civility shall be observed. In case more than one member shall seek recognition to address the Board or committee, the Chair shall decide who has precedence.
- J. All regular meetings of the Board and Board committees shall provide a noticed public comment period. During a public comment period, any person who is not a member of the

body may comment on a specific item or issue that is on that particular agenda for a maximum of three minutes per person. Based on the number of people registered to comment, the chair has discretion to limit public comment to two minutes and shall announce said restriction prior to public comments commencing. Any person who wishes to comment on a matter not on the County Board agenda shall provide their comment to the County Clerk in writing for possible distribution to the Board. Discussion of personalities is prohibited and civility shall be observed. The Board or committee Chair may authorize the appearance and comment of a non-member if the appearance is specifically listed on the agenda.

- K. Any member wishing to speak to a question shall be permitted to do so at least once, and a motion for the previous question shall not be in order until every member has had such opportunity. No member may speak twice on any question until every member choosing to speak has spoken. The person making a motion and the second may speak for up to five (5) minutes during the first round of debate and all others shall be limited to three (3) minutes per round.
- L. All Supervisors present in person and remotely are expected to vote on all questions and items put before the Board or Committee. A Supervisor who has a conflict of interest pursuant to Wis. Stat. § 19.59 or Sauk Co. Code Ch. 36, Code of Ethics, shall, prior to the commencement of discussion or consideration of the matter, or as soon thereafter as the conflict of interest is discovered, declare the same. The Chair shall be excused by the Vice-Chair, for appropriate reasons. A Supervisor who chooses to abstain from voting for any other reason should likewise, prior to the commencement of discussion or consideration of the matter, declare that they will be abstaining. All members abstaining shall be deemed present for purposes of a quorum even if absence from the chambers is required.
- M. Every motion shall be reduced to writing if called for by the Chair or any member of the Board. After motion is made and stated by the Chair, it shall be deemed to be in the possession of the Board, but may be withdrawn at any time before decision or amendment by a majority vote of the Board.
- N. In every instance, a motion to adjourn, to lay on the table, for previous question and for limited debate shall be decided without discussion.
- O. Except for resolutions approved as part of a consent agenda, all votes on resolutions or ordinances shall be recorded roll call votes. If the electronic voting system is not operational, the Board may, by a two-thirds vote, approve voice voting on any resolution that does not otherwise require a roll call or supermajority vote by law.
- P. Any budget alterations shall require authorization by two-thirds of the membership of the Board in accordance with Wis. Stat. § 65.90(5).
- Q. When a motion has been made and carried in the affirmative or negative, it shall be in order for any member of the majority to move for reconsideration thereof at the next regularly scheduled meeting or in the same meeting of the Board. Such motion shall take precedence over all other questions except a motion to adjourn.
- R. Reports to the Board are presented for information and not debate, and shall be limited to ten minutes in length after which a question and answer period may be conducted that also shall not exceed ten minutes. The time provided for a report or question and answer period may be

extended either during the approval of the agenda or by motion to extend the time allowed for the report or the question and answer period.

- S. The Board shall take a ten-minute break after two hours of meeting, and shall break for ten minutes every two hours thereafter, for the comfort of supervisors and members of the public attending the meeting.
- T. Remote Participation in Sauk County Board and Committee Meetings:

The Chair of the Board or a Committee may *not* remotely preside over any meeting.

A Supervisor may remotely attend, be counted towards a quorum, vote and be paid per diem as Follows:

COUNTY BOARD MEETING:

1. Supervisor must request remote participation in a meeting of the full County Board of the Chair at least 72-hours prior to the meeting, and notify the County Clerk if and once such request is granted by the Chair.
2. Supervisor may participate via voice or video; may speak only when recognized by the Chair pursuant to all other applicable rules of the board; may vote **ONLY** using County approved, properly configured, and secured voting device.
3. An individual Supervisor may remotely attend a meeting no more than three (3) times per two-year term.
4. No more than two Supervisors may remotely attend and participate in a meeting of the full County Board.
5. Remote participation in closed session is not allowed.
6. The Chair may alter the provisions of this paragraph to allow for unforeseen or urgent circumstances.

COMMITTEES OF THE COUNTY BOARD:

1. Supervisor must request the remote participation in a Committee meeting of the Committee Chair at least 72 hours prior to the meeting, and notify the Secretary of the Committee if and once such request is granted by the Chair.
2. Supervisor may participate and vote via voice or video; may speak only when recognized by the Chair pursuant to all other applicable Rules of the Board and Committee.
3. An individual Supervisor may remotely attend a meeting no more than three (3) times per two-year term.
4. No more than one (1) Supervisor may remotely attend and participate in a Committee meeting.
5. Remote participation in closed session is not allowed.

6. The Chair may alter the provisions of this paragraph to allow for unforeseen or urgent circumstances.

SAUK COUNTY HEALTHCARE CENTER

Sauk County Health Care Center (SCHCC) staff who participate in the SCHCC trustees meetings may do so remotely when they need to remain at the SCHCC for health and safety reasons. Citizen members of the SCHCC trustees may participate in meetings remotely when health and safety is a concern.

- U. All proposed Board agenda items shall be submitted in writing to the County Clerk and County Administrator by 4:30 p.m. on the Tuesday preceding the next regular meeting of the Board. The County Administrator is responsible for the referral and routing of all proposed resolutions and other items to come before a committee and the Board. Except as otherwise provided, all proposed Board agenda items shall be referred to each standing committee with subject matter jurisdiction prior to placement on the Board agenda for discussion, report, and recommendation. Any Supervisor may also present a proposed resolution or agenda item for consideration by the full Board utilizing one of the following processes:
 1. A Supervisor may request the committee chairman to place a proposed resolution or other item on the agenda of the next regular meeting of a committee of which he is a member; or
 2. A Supervisor may request the County Administrator to refer a proposed resolution or item to the appropriate committee for consideration at its next regular meeting, if the requestor is not a member of that committee.

All business referred to a committee by the Board shall be taken up before the next regular Board meeting whenever possible. The Board may, by majority vote, recall any matter referred to a committee and refer the matter to another committee or take other appropriate action thereon. A Supervisor wishing to so recall an item from Committee must notify the County Administrator by the time set forth in III. A. so the proposed action may be properly included on the Board agenda. Supervisors are strongly encouraged to consider the recommendation of the committee prior to requesting a proposed resolution or item be placed on the agenda as the lack of committee support would be indicative of the proposed resolution's or item's feasibility.

- V. Items may be included on the general consent portion of the agenda provided the matter was unanimously adopted by the sponsoring committee and the matter under consideration has no financial or public policy impact and is of a non-controversial nature. No ordinance shall be included in the general consent portion of the agenda. When the general consent portion of the agenda is placed before the Board for consideration, the Chair shall ask if any member of the Board objects to any item being considered by general consent. Any item placed on the general consent portion of the agenda may be placed under the new business portion of the agenda, and considered separately, upon the request of any supervisor, and without a motion and second, provided such request is made prior to a vote on the general consent portion of the agenda by the Board. If there is no objection to any item, the Chair will request a motion to approve the general consent portion of the agenda. All items in the general consent portion of the agenda may be approved by voice vote. Any member may request and

shall be granted a recorded vote without a motion or second provided such request is made prior to the Chair's request for a motion to approve the consent agenda.

- W. It shall be the responsibility of the sponsoring committee or supervisor to have the matter prepared in the form to be acted on and to have a fiscal note attached. All resolutions involving the expenditure or receipt of funds shall carry a fiscal note using a form approved by the Finance Committee which details the resolution's impact upon County finances approved and initialed by the Finance Director, Finance Manager or County Administrator. In addition to the fiscal note, all resolutions shall contain a Management Information Systems (MIS) Note, and shall be reviewed by Corporation Counsel and approved as to form prior to inclusion in the agenda. A resolution lacking a fiscal note, MIS note, or legal review by Corporation Counsel shall not be considered by the Board. The background clause of any resolution or ordinance shall contain information sufficient to provide the purpose and need for the resolution or ordinance.
- X. The Chair may immediately refer any matter not considered and reported to the Board by a committee to the appropriate committee without motion if there is no objection to referral. If objection is made, referral of the matter shall be immediately placed before the Board for vote and shall only be referred upon a majority vote of the members present and voting. Resolutions brought forward by individual supervisors must be presented to all committees having jurisdiction over the proposed matter as detailed above.
- Y. The County Board shall send a special advisory referendum question, pursuant to Wisconsin State statute 59.52(25), to the County Clerk for placement on the next spring or fall ballot only if a supervisor submits the question in writing to the Board not less than one-hundred-twenty (120) days prior to the date of the next election and the question is approved for ballot placement by a two-thirds (2/3rds) vote of the Board.

RULE IV Committees

A. Matters Pertaining to Standing Committees of the Board:

1. A supervisor shall serve as a committee member until the first Board meeting following the spring County Board Supervisor election.
2. A chair, vice-chair and secretary for each committee shall be selected by each committee's membership. Only Supervisors may hold these positions. Supervisors may only be the Chair of one standing committee. A Supervisor elected to be the chair of a two Committees shall resign as the Chair of one of the Committees.
3. If the position of chair on a committee becomes vacant, the vice-chair becomes chair and an election shall be held to fill the position of vice-chair and any other subsequent vacancies.
4. A supervisor may only be removed from a committee by the County Board Chair with the approval of the County Board by a two-thirds vote of the Board members present.
5. If a supervisor wishes to resign from a committee, permission must be requested from the Board. Permission of the Board can be given through

unanimous consent or a motion that is debatable and amendable. Once the request is granted, the vacancy is handled as any other vacancy.

6. Whenever two or more committees meet jointly, a quorum of each committee participating in the joint meeting is required. A supervisor who serves on two or more of the committees may be counted toward a quorum of more than one of the committees meeting jointly. The joint committees shall vote to select one chair of one of the participating committees to serve as chair of the joint meeting.
7. Supervisors are expected to attend the committee meetings of the committees to which they are assigned. When a supervisor cannot attend a meeting, it is the responsibility of the supervisor to request excusal from the chair of the committee.
8. A County Board member attending a committee meeting of a committee on which they do not serve, shall be given the opportunity to address said committee at least once, for a period of time which is at least equal to the time allowed for individual speakers at public comment, provided the matter to be addressed is a matter that is on that committee's properly posted agenda. The decision to allow the supervisor to speak more than once is within the discretion of the chair of the committee. The chair's decision may be overruled by a majority vote of the committee.
9. Each committee shall, at its first meeting following the organizational meeting of the Board, select those officers required by Rule IV.L., and it shall thereafter be the responsibility of said officers to ensure that accurate, written minutes are made of each meeting of the committee and submitted to the County Clerk for filing. The presiding officer at any meeting shall ensure compliance with the Open Meetings Law.
10. Committee agenda format will be established in compliance with open meetings law and by the committee chair and secretary based on that respective committee's precedent.

B. Special committees, boards, special appointments and commissions shall be selected or appointed by the Chair with the approval of the Board. These committees, boards and commissions shall select their own chair. The Chair shall notify the supervisors of proposed appointments by United States Mail or email no later than the Thursday afternoon prior to the scheduled meeting of the Board at which the appointments will be voted upon. If an appointment is to be considered at a special meeting of the Board, the Chair shall provide notice by United States Mail or email no later than five days prior to the date of the special meeting.

STANDING COMMITTEES OF THE BOARD.

AGING & DISABILITY RESOURCE CENTER COMMITTEE

Responsible for providing services to the general public with respect to matters related to aging and disability and to improve the life of those with aging and disability related issues. This committee will serve as the official statutory

Commission on Aging pursuant to Wis. Stat. § 46.82(4) and shall be advised by the Aging, and Disability Advisory Committee. Responsible for policy direction and oversight for the following departments: Aging and Disability Resource Center. See, Sauk Co. Code Ch. 16. Oversight Committee for the Healthcare Center Board of Trustees.

Members: 11. The Committee shall have 6 County Board Supervisors.

ECONOMIC DEVELOPMENT COMMITTEE

Responsible for coordination of County economic development initiatives with County Planners and Sauk County Development Corporation. Involved in strategic resource planning initiatives. Reviews matters which affect growth and development of Sauk County, and economic development of communications network. Responsible for economic development in Sauk County and oversees County coordinated transportation, including overseeing the Tri-County Airport Commission, municipal airports, Pink Lady Rail Transit Commission and Wisconsin River Rail Transit Commission. Responsible for the study, review and recommendation regarding freight, passenger and commuter rail development, intercity and commuter bus services and development, and the provision and coordination of rural and commuter transit services. Transit is governed by Wis. Stat. s. 59.58. Also responsible for oversight regarding arts, humanities, culture and historic preservation projects on behalf of the Board. Serves as the Landmarks Commission in compliance with Sauk Co. Code Ch. 38 and Wis. Stats. §§ 59.56 and 59.69(4m). **Members: 7.**

EXECUTIVE & LEGISLATIVE COMMITTEE

Responsible for proposing amendments and monitoring the operation of Rules of the Board; responsible for the conduct of all intergovernmental relations and affairs; monitors State legislative and administrative activity affecting Sauk County; proposes legislation or action on pending legislation affecting Sauk County; considers matters not specifically assigned to other committees. Responsible for policy direction and oversight to the following departments: County Administrator, Corporation Counsel, County Clerk, Emergency Management. This committee shall also have oversight of the Veteran Services Office.

Comprised of members from: **The Executive & Legislative Committee shall be composed of the Chair and Vice-Chair of the Board, along with the Chair of the other Standing Committees. The Chair of the Committee shall vote only in the case of a tie.** The County Clerk shall serve as secretary to this committee. The County Administrator, Corporation Counsel, and County Clerk shall serve as *ex officio* members of this committee without voting privileges. **Members: 9.**

FINANCE, PERSONNEL & INSURANCE COMMITTEE

Responsible for financial policy initiation and review of all County fiscal matters, including reviewing and possibly revising the annual County operating budget, submitted to the Committee by the County Administrator, for presentation to the Board. Reviews County investment and banking policies; manages County general fund and contingency fund; reviews per diem and mileage for all committees, commissions, boards or councils; recommends approval of County audit report; receives all special gifts and grants made in favor of the County. Responsible for policy jurisdiction over all County personnel matters including: recruitment and selection; collective bargaining and contract administration; employee relations; salary administration for all appointed and elected personnel;

classification systems; employee training; fringe benefits; and reviews all new position requests and vacant positions. Oversees the County's safety program and safety training. Provides for all property, liability, and worker's compensation insurance needs for the County. Provides policy direction and oversight to Accounting, County Treasurer, the Personnel Department and Risk/Safety Manager. **Members: 9.**

HEALTH RESOURCES

Responsible for policy direction and oversight of Health Department pursuant to Wis. Stat. Chs. 250 through 255 relating to public and environmental health matters. See, Sauk Co. Code Ch. 3. Responsible for policy direction and oversight for Human Services Department pursuant to Wis. Stat. chs. 46 and 51 and Wis. Stat. § 59.53 to oversee social services and community programs. **Members: 9; 5 Supervisors, 1 M.D., 1 R.N., One member that represents the diversity of the county, 1 member who receives, or has a family member that receives, services from the Department of Human Services.**

LAND RESOURCES & ENVIRONMENT COMMITTEE

Responsible for policy direction for County planning, land use regulations, surveying, remonumentation, mapping and uniform rural building identification system, land records modernization activities. Serves as the County Zoning Agency pursuant to Wis. Stat. § 59.69. Establishes policies relating to planning, acquisition, development and maintenance of County owned park and recreation sites. Responsible for natural resource management, resource conservation and environmental protection including soils, water, forestry and wildlife resources through participation in various federal, state and local programs. Responsible for developing sustainable practices within County operations and serving in an advisory capacity regarding "green technologies." Responsible for the development and implementation of the Sauk County Outdoor Recreation Plan. Responsible for review and approval of vouchers related to the Sauk County Outdoor Recreation Plan. Oversees operation of farmland located at the original Sauk County Health Care Center. Serves as the Farmland Preservation Review Committee. Also, jointly responsible with the Area Extension Director for oversight of University of Wisconsin-Madison, Division of Extension educational programming in agriculture and natural resources, community and economic development, family living, 4-H and positive youth development, horticulture, and County tourism and promotion activities on behalf of the Board.

Members: 9; 7 Supervisors, 6 of whom shall be Supervisors from districts that have at least a portion of their district in County Zoning, 1 Citizen who meets the requirements of Wis. Stat. § 92.06(1)(b)(2), 1 citizen may be appointed who shall be a public school administrator in the County. If there is no school administrator appointed then a Supervisor shall be appointed to fill that spot on the committee. Pursuant to Wis. Stat. § 92.06(1)(b)(2) the designee shall be a person who is engaged in agricultural use, as defined under s. 91.01 (2)(a)1, and shall be a member of the Committee but shall refrain from discussion and voting on any matter where the Committee is acting as the County Zoning Agency. A public school administrator, if one is appointed, shall be a Member of the Committee but shall refrain from voting on matter not related to UW-Extension. Members of this committee shall serve on the lake protection districts. Provides policy direction and oversight to the following departments: Land

Resources and Environment; Parks; County Surveyor; Land Information Officer; Register of Deeds; and Mapping.

LAW ENFORCEMENT & JUDICIARY COMMITTEE

Responsible for exploration of justice alternatives. Provides policy direction and oversight on behalf of the Board to the following departments: District Attorney, Coroner, Clerk of Courts, Court Commissioner, Register in Probate, Child Support, and Circuit Court Judges, Sheriff, and the Animal Shelter. **Members: 9.**

PUBLIC WORKS AND INFRASTRUCTURE COMMITTEE

Responsible for policy direction in design, construction and maintenance of all County roads and expenditure of highway maintenance funds received from the state or County, including planning, development of, and maintenance of all structures required for storage, maintenance and operations relating to the Highway Department. Pursuant to Wis. Stat. § 83.015(1)(c), this Committee is designated the County Highway Committee and each member is appointed and vacancies filled pursuant to the procedures contained in these Rules. Responsible for policy direction and oversight for Highway Department. Responsible for providing policy direction with regard to matters involving County property. Handles all matters relating to the acquisition of real property, construction, building improvements, repair or maintenance not specifically delegated to other committees. Responsible for planning and implementation of space use in County buildings. Oversees the appraisal and sale of tax delinquent County property by the County Treasurer and reviews the disposition of, or the granting of easements on, County real property. Responsible for the physical management requirements associated with the closed Sauk County Landfill. Approves the use of County owned property by non-County groups when such property is not under the direct purview of another committee. Oversees communications infrastructure, including fiber optic cable, towers, and associated equipment. Responsible for the overall information technology requirements for all departments and agencies of Sauk County. Responsible for oversight of the Management Information Systems department. Provides overall planning and long-range forecasting for the information systems needs of Sauk County. Provides oversight to the Building Services Department **Members: 9.** [Drafter's Note: Elimination of the Communications & Infrastructure Committee and transfer of its functions to the Property Committee was approved on April 29, 2019 but is not effective until April 21, 2020]

RULE V. Miscellaneous Provisions

- A. The County Administrator shall attend Board meetings.
- B. The Corporation Counsel shall attend Board meetings and serve as parliamentarian and legal advisor to the Board. If the Corporation Counsel is unable to attend a Board meeting, then the County Administrator will serve as parliamentarian.
- C. Amendments/Changes to the Rules of the Sauk County Board of Supervisors during the current term shall be proposed and adopted pursuant to the following procedure:
 1. Proposed amendments to these rules shall first be reviewed by the Executive &

Legislative Committee (E&L). The proposed amendment shall then be introduced to the Board at the subsequent Board meeting.

2. The proposed amendment shall be read under the "Reports" section of the agenda. The sponsoring Supervisor may speak to the proposed rule change for up to 5 minutes. The Board shall take no action at this point. Supervisors may relay their comments on the proposed amendment to the sponsoring Supervisor afterwards, ideally via email.
 3. E&L shall then consider the proposed original or revised amendment at its subsequent meeting and forward a recommendation to adopt or not adopt to the full Board. The full Board will consider the proposed or revised amendment at its next regular meeting, with a 2/3 vote of all members present required for adoption.
 4. E&L Committee shall begin review the County Board Rules in September of odd years for consideration for presentation at the October County Board Meeting.
- D. The County Administrator, with the assistance of the Finance Director, shall keep the Board informed of the financial condition of the County and shall submit complete quarterly financial statements to the Board.
- E. These rules may be suspended or amended by a two-thirds vote of all members present. Robert's Rules of Order Newly Revised, 2011 (11th) Edition, shall govern the proceedings of the Board in all cases to which they are applicable and in which they are not inconsistent with these Rules or the laws of the State of Wisconsin.

MINUTES

SAUK COUNTY BOARD OF SUPERVISORS

JANUARY 16, 2024

WEST SQUARE BUILDING, 505 BROADWAY, ROOM 326, BARABOO, WI

REGULAR MEETING: SAUK COUNTY BOARD OF SUPERVISORS

1. Call to Order and Certify Compliance with Open Meeting Law: 6:00 P.M.

2. Roll Call. PRESENT: (27) Roxen, T. Spencer, Eberl, Rego, Klitzke, Scanlon, Krueger, Flint, Clemens, Lombard, Schell, Dorner, Fordham, Astle, Hazard, R. Spencer, Carver, Polivka, Burchill, Peper, Gruber, Detter, Chrisler, Stehling, McAuliffe, Deitrich and McCumber. ABSENT: (4). Kinsman, Anderson, Prosser, and Lohr.

Staff Present: Brent Miller, County Administrator; Brian Desmond, Corporation Counsel; Autumn Bates, Lead Deputy County Clerk; Chris Harry, Deputy County Clerk; Cora McDonnell, Deputy County Clerk; and Michelle Commings, Deputy County Clerk.

3. Invocation and Pledge of Allegiance. Invocation given by Supr. Burchill

*Supr. Kinsman arrived at 6:05 p.m.

4. Adopt Agenda. MOTION (Schell/Roxen).

The following scrivener error was noted:

"Resolution 4-2024 Amending The ~~2023~~ 2024 Budget To Appropriate \$90,259 Pursuant To An Intergovernmental Agreement Between Sauk County, Wisconsin, and the Ho-Chunk Nation."

Motion carried **unanimously**.

5. Adopt the minutes. MOTION (Carver/Klitzke) to adopt the minutes from the previous meeting. Motion carried **unanimously**.

6. General Consent Agenda Items.

a. **EXECUTIVE & LEGISLATIVE COMMITTEE:**

i. **Resolution 1-2024 To Honor Michelle Commings For Over 25 Years Of Faithful Service To The People Of Sauk County.**

MOTION (Peper/Klitzke) to approve General Consent Agenda item. Motion carried **unanimously**.

7. Scheduled Appearances. None.

8. Public Comment. None.

9. Communications.

a. 01/04/2024 Letter from Art Carlson, re: Sauk County Health Care Center.

10. Appointments.

a. **Workforce Development Board of South-Central Wisconsin**

Ben Breese, New Appointment, Citizen Member

3 – year term: 01/16/2024 - 01/20/2027

b. Sauk County 2024 Emergency Fire Wardens: (attached to Granicus)
MOTION (Fordham/Peper) to approve the appointments. Motion carried **unanimously**. (Voice vote)

11. **Bills.** None.

12. **Claims.** None.

13. **Elections.** None.

14. **Proclamations.** None.

15. **Reports – informational, no action required.**

a. Rebecca C. Evert, Sauk County Clerk – Rezoning petitions filed with the office of the Sauk County Clerk as a requirement of Wisconsin State Statutes 59.69(5)(e): none.

b. Brent Miller

i. Administrator's report.

c. Tim McCumber, County Board Chair

i. Board Chair Update.

16. **Unfinished Business.** None.

17. **New Business.**

BOARD OF HEALTH:

Resolution 2-2024 To Authorize Contract Services with Flourish & Thrive Labs.

MOTION (Rego/McAuliffe). VOTE: AYES: (28) Roxen, T. Spencer, Eberl, Rego, Kinsman, Klitzke, Scanlon, Krueger, Flint, Clemens, Lombard, Schell, Dorner, Fordham, Astle, Hazard, R. Spencer, Carver, Polivka, Burchill, Peper, Gruber, Detter, Chrisler, Stehling, McAuliffe, Deitrich and McCumber. NAYS: (0).

ABSENT & EXCUSED: (3) Anderson, Prosser, and Lohr. Motion carried **unanimously**.

PROPERTY COMMITTEE & LAND RESOURCES AND ENVIRONMENT COMMITTEE:

Resolution 3-2024 To Sell A Highway Easement Of 1,046 Sq Feet Of Sauk County Land To The Wisconsin Department Of Transportation At The Sauk County Farm.

MOTION (Polivka/Detter). VOTE AYES: (28) Roxen, T. Spencer, Eberl, Rego, Kinsman, Klitzke, Scanlon, Krueger, Flint, Clemens, Lombard, Schell, Dorner, Fordham, Astle, Hazard, R. Spencer, Carver, Polivka, Burchill, Peper, Gruber, Detter, Chrisler, Stehling, McAuliffe, Deitrich and McCumber. NAYS: (0).

ABSENT & EXCUSED: (3) Anderson, Prosser, and Lohr. Motion carried **unanimously**.

FINANCE COMMITTEE:

Resolution 4-2024 Amending The 2024 Budget To Appropriate \$90,259 Pursuant To An Intergovernmental Agreement Between Sauk County, Wisconsin, and the Ho-Chunk Nation.

MOTION (Krueger/Scanlon). VOTE AYES: (28) Roxen, T. Spencer, Eberl, Rego, Kinsman, Klitzke, Scanlon, Krueger, Flint, Clemens, Lombard, Schell, Dorner, Fordham, Astle, Hazard, R. Spencer, Carver, Polivka, Burchill, Peper, Gruber, Detter, Chrisler, Stehling, McAuliffe, Deitrich and McCumber. NAYS: (0).

ABSENT & EXCUSED: (3) Anderson, Prosser, and Lohr. Motion carried **unanimously**.

18. **Referrals.**

19. **New Agenda items (no discussion).** Submit in writing or by e-mail new business items to the County Administrator as soon as possible for Rule III.A. referral.

20. **Adjournment to a date certain:** 6:26 P.M. MOTION (T. Spencer/Carver) to adjourn until Tuesday, February 20, 2024, at 6:00 P.M. Motion carried **unanimously**.

Respectfully submitted,



Cora Lisa McDonnell
Deputy County Clerk

Minutes Approved: February 20, 2024.

State of Wisconsin, County of Sauk: I certify that the above is a true and correct copy of the January 16, 2024. Proceedings of the Sauk County Board of Supervisors.

Original documents on file @ Office of the Sauk County Clerk West Square Building, 505 Broadway, Room #144, Baraboo, WI 53913. 608-355-3286.

www.co.sauk.wi.us

These notices may also be found at: <http://www.wisconsinpublicnotices.org/> or <https://www.co.sauk.wi.us/legalnotices>.

RESOLUTION # 1 -2024

Resolution to Honor Michelle Commings for over 25 years of Faithful Service to the People of Sauk County

Resolution offered by the Executive & Legislative Committee
Resolved by the Board of Supervisors of Sauk County, Wisconsin:

BACKGROUND: It is custom of the Sauk County Board of Supervisors to recognize staff members who have served the people of Sauk County with distinction. Michelle Commings faithfully served the people of Sauk County by providing over 25 years of service for Sauk County. Michelle started on August 31, 1998 as Deputy Register of Deeds. On March 26, 2012 she transferred to the County Clerk's Office as Deputy County Clerk. In 2016 Michelle became Lead Deputy County Clerk where she will retire on February 2, 2024. Michelle maintained professional and ethical integrity while serving the County. Michelle was an essential team member to the Sauk County Clerk's Office and all of Sauk County.

THEREFORE, BE IT RESOLVED, that the Sauk County Board of Supervisors, met in regular session, hereby expresses its appreciation, and commends Michelle Commings for over 25 years of faithful service to the people of Sauk County; and

BE IT FURTHER RESOLVED, that the Chairperson of the Sauk County Board of Supervisors is hereby directed to present Michelle Commings an appropriate certificate and commendation as a token of our esteem.

Approved for presentation to the County Board by the Executive & Legislative Committee, this 16th day of January 2024.

Consent Agenda Item: [] YES [X] NO

Fiscal Impact: [X] None [] Budgeted Expenditure [] Not Budgeted

Vote Required: Majority = X 2/3 Majority = _____ 3/4 Majority = _____

The County Board has the legal authority to adopt: Yes X No _____ as reviewed by the Corporation Counsel, [Signature], Date: 01.10.2024

Offered and passage moved by:

_____	<input type="checkbox"/> Aye	<input type="checkbox"/> Nay	<input type="checkbox"/> Abstain	<input checked="" type="checkbox"/> Absent
Timothy McCumber, Chair				
_____	<input checked="" type="checkbox"/> Aye	<input type="checkbox"/> Nay	<input type="checkbox"/> Abstain	<input type="checkbox"/> Absent
John Deitrich				
_____	<input checked="" type="checkbox"/> Aye	<input type="checkbox"/> Nay	<input type="checkbox"/> Abstain	<input type="checkbox"/> Absent
Carl Gruber				
_____	<input checked="" type="checkbox"/> Aye	<input type="checkbox"/> Nay	<input type="checkbox"/> Abstain	<input type="checkbox"/> Absent
Brian Peper				
_____	<input checked="" type="checkbox"/> Aye	<input type="checkbox"/> Nay	<input type="checkbox"/> Abstain	<input type="checkbox"/> Absent
Marty Krueger				

Fiscal Note: No Impact. [Signature]
MIS Note: No Impact.

RESOLUTION # 2-2024

Resolution to Authorize Contract for Services with Flourish & Thrive Labs

Resolution offered by the Board of Health

Resolved by the Board of Supervisors of Sauk County, Wisconsin:

BACKGROUND:

Public Health received a grant from The Medical College of Wisconsin. One of the project aims is to establish one metric for the performance management dashboard that explores a social determinant of health's impact on maternal/child outcomes. To do this Flourish and Thrive Labs was selected based on their proven ability and lowest price provided.

THEREFORE, BE IT RESOLVED, by the Sauk County Board of Supervisors that the provision of services by Flourish & Thrive Labs at a cost of \$17,000 be hereby approved.

Approved for presentation to the County Board by the _____ Committee, this ____ day of _____, 2023

Consent Agenda Item: [] YES [] NO

Fiscal Impact: [] None [] Budgeted Expenditure [] Not Budgeted

Vote Required: Majority = _____ 2/3 Majority = _____ 3/4 Majority = _____

The County Board has the legal authority to adopt: Yes _____ No _____ as reviewed by the Corporation Counsel, _____, Date: _____

Offered and passage moved by: Sauk County Board of Health

- Pat Rego [] Aye [] Nay [] Abstain [] Absent
Rebecca Klitzke [] Aye [] Nay [] Abstain [] Absent
Thomas Dornier [] Aye [] Nay [] Abstain [] Absent
Dave Clemens [] Aye [] Nay [] Abstain [] Absent
Kiana Beaudin [] Aye [] Nay [] Abstain [] Absent
Dr. Barclay Shultz [] Aye [] Nay [] Abstain [] Absent

52 Fiscal Note: \$17,000 in contractual expenses will derive from Community Led Maternal Child
53 Health Grant (Project Code 05566). *JMA*
54
55 MIS Note: None

RESOLUTION # 3-2024

Resolution to Sell a Highway Easement of 1,046 sq feet of Sauk County land to the Wisconsin Department of Transportation at the Sauk County Farm

Resolution offered by the Property Committee & Land Resources and Environment Committee

Resolved by the Board of Supervisors of Sauk County, Wisconsin:

BACKGROUND: The Wisconsin Department of Transportation (WI DOT) will be reconstructing a portion of State Highway 23 from Elder Ridge Road to County Road K. The purpose of the project is to extend the life of the existing pavement and improve pavement riding characteristics, guardrail replacement, culvert replacement, water/sanitary sewer replacement (Village of Loganville) and bring sidewalk curb ramps into compliance with Americans with Disabilities Act (ADA) standards. The area of interest at the Sauk County Farm is 1,046 square feet or approximately 0.024 acres in size. All documentation related to the sale of a highway easement will be signed by the County Administrator and County Clerk.

THEREFORE, BE IT RESOLVED, that the County Board authorizes the sale of a highway easement of 1,046 square feet of County property for \$500; and

BE IT FURTHER RESOLVED, that all documentation related to the sale of a highway easement will be signed by the County Administrator and County Clerk.

Approved for presentation to the County Board by the Property Committee, this 16th, day of January 2024

Consent Agenda Item: [] YES [] NO

Fiscal Impact: [] None [] Budgeted Expenditure [X] Not Budgeted

Vote Required: Majority = _____ 2/3 Majority = X 3/4 Majority = _____

The County Board has the legal authority to adopt: Yes X No _____ as reviewed by the Corporation Counsel, [Signature], Date: 01.10.2024

Offered and passage moved by:

PROPERTY COMMITTEE

[Signature] X Aye [] Nay [] Abstain [] Absent
Carl Gruber

[] Aye [] Nay [] Abstain X Absent
Mark "Smooth" Dettner

[] Aye [] Nay [] Abstain X Absent
Joel Chrisler

52
53
54
55
56
57
58
59
60
61
62
63
64
65
66
67
68
69
70
71
72
73
74
75
76
77
78
79
80
81
82
83
84
85
86
87
88

Robert Spencer

Aye Nay Abstain Absent

~~Mike Anderson~~ **JAMES ASTLE**

Aye Nay Abstain Absent

LAND RESOURCES AND ENVIRONMENT COMMITTEE

Marty Krueger, Chair

Aye Nay Abstain Absent

Peter Kinsman, Vice Chair

Aye Nay Abstain Absent

Brandon Lohr

Aye Nay Abstain Absent

Dennis Polivka

Aye Nay Abstain Absent

Robert Spencer

Aye Nay Abstain Absent

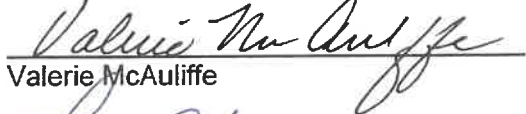
Valerie McAuliffe

Aye Nay Abstain Absent

Lynn Eberl

Aye Nay Abstain Absent

Randy Puttkamer

Aye Nay Abstain Absent

Fiscal Note: Funds from the sale of the highway easement will be deposited into the General Fund.

MIS Note: None



November 30, 2023

SAUK COUNTY
S4555 COUNTY ROAD CH
REEDSBURG, WI 53959

Project: ID 5080-09-23, Parcel No. 11
SPRING GREEN - REEDSBURG
STH - 023, Sauk County

Dear SAUK COUNTY:

As you may know, the Wisconsin Department of Transportation (WisDOT) plans a highway safety project in your area. This project will affect your property and I look forward to working with you to discuss our mutual interests.

Please review the following documents:

- Right of Way Plat with names of neighboring landowners affected by the project
- Waiver of Appraisal Form
- Conveyance with legal description of the land and/or interest(s) needed for the project
- "The Rights of Landowners Under Wisconsin Eminent Domain Law" pamphlet
- Statement to Construction Engineer

To determine fair compensation for your interests, the department conducted a market study of recent comparable sales in the area. These values and associated interests are noted on the enclosed Waiver of Appraisal form. In non-complex acquisitions, such as this one, a formal appraisal is not required.

If you agree with the terms shown on the Waiver of Appraisal form, please sign the following documents and return them in the enclosed envelope for final review and approval by the department.

Waiver of Appraisal. This form needs to be signed and dated by all owners. This verifies that you have waived your right to a formal appraisal and agree to accept settlement in the amount stated on the form.

Conveyance. The Highway Easement conveyance document will need a notarized signature of all owners.

Statement to Construction Engineer form. This informs the contractor of any concerns. Even if there are no concerns, this form will still need to be signed.

Please note both your signature and that of the Wisconsin Department of Transportation are needed for an enforceable contract. After the department reviews and signs the document, a fully executed (signed) copy of the documents will be sent to you, and I will contact you to arrange for payment and closing.

If you do not agree with the terms of the enclosed Waiver of Appraisal form, or if I have not heard back from you by 1/2/2024, I will contact you to discuss the next steps in the acquisition process. If you have questions, please contact me at 608-609-8821.

Sincerely,

TerraVenture Advisors, LLC

Teri Weil
Real Estate Specialist

Enclosures

FACT SHEET
ID 5080-09-23
Spring Green – Reedsburg
(Elder Ridge Road to CTH K)
STH 23
Sauk County

PROJECT DESCRIPTION

The project length is 8.11 miles long. This is a reconstruction project of STH 23 beginning at Elder Ridge Road and ending at County Road K.

NEED FOR PROJECT

This roadway was last reconstructed/resurfaced in 2005. The existing pavement is aged and exhibits signs of fatigue including alligator, longitudinal, and traverse cracking. Existing curb ramps do not meet Americans with Disabilities Act (ADA) standards.

IMPROVEMENTS

The purpose of this project is to extend the life of the existing pavement and improve pavement riding characteristics, guardrail replacement, culvert replacement, water/sanitary sewer replacement (Village of Loganville), and bring sidewalk curb ramps into compliance with ADA standards to the extent feasible.

CONSTRUCTION

Construction is anticipated to start in the spring of 2025. During construction, STH 23 will be detoured during construction. Temporary driveway closures may be necessary during parts of the construction process. Construction staff will contact homeowners and businesses in advance before closing a driveway.

REAL ESTATE

The acquisition process is expected to start in November 2023 and be completed by August 2024.

FEE ACQUISITION

This means the state will purchase the land permanently.

HE ACQUISITION

A Highway Easement (HE) is an acquisition of land for highway purposes. The property remains on the owner's county tax records, but its use is denied to the owner as long as the property is used for highway purposes.

TLE ACQUISITION

A Temporary Limited Easement (TLE) is usually needed for grading purposes during construction only. This easement will allow the contractors to complete their work. After the project is complete, the easement will terminate.

ENCROACHMENT

An encroachment is any trespassing on the domain of another, e.g., wall, fence, landscaping, building, etc.

COMPENSATION

About three weeks after the conveyance form has been signed, a check will be mailed.

**NOMINAL PAYMENT PARCEL - WAIVER OF APPRAISAL
RECOMMENDATION AND APPROVAL**

Wisconsin Department of Transportation

RE1897 01/2023 Ch. 32 Wis. Stats.

Owner name(s) Sauk County	Area and interest required 0.024 acres of Highway Easement (HE)
------------------------------	--

Allocation

Allocation	Description	Size	Unit	Per Unit	Value (\$)
Highway Easement (HE)	(1,046 SF @ \$0.16)	0.024	Acres	\$6,973.33	\$167.36
Appraiser Rounding					\$332.64

Total Allocation \$500.00
Rounded To \$500.00

The undersigned owner(s), having been fully informed of the right to have the property appraised, and to receive just compensation based upon an appraisal, have decided to waive the right to an appraisal and agree to accept settlement in the above-stated amount as full payment for the parcel stated, subject to approval by Wisconsin Department of Transportation.

The undersigned owner(s) further states that they waived the right to an appraisal without undue influences or coercive action of any nature.

It is intended that the instrument of conveyance will be executed upon presentation by Wisconsin Department of Transportation agents or representatives.

FOR: Sauk County

X	_____	X	_____
Owner Signature	Date	Owner Signature	Date

Approved for Wisconsin Department of Transportation	For Office Use Only
---	---------------------

X

Wisconsin Department of Transportation Signature
Date



Q J 1 0 8 3 4 4 7

This instrument was drafted by
Wisconsin Department of Transportation

430

Project ID
5080-09-23

Parcel No
11

HIGHWAY EASEMENT

Wisconsin Department of Transportation
Exempt from filing transfer form [77.22(1) Wis. Stats.]
RE1565 01/2023 Exempt from fee: s.77.25(2r) Wis. Stats..

THIS EASEMENT, made by **The County of Sauk of the State of Wisconsin**, GRANTOR, conveys an easement, as described below, for highway purposes to the Wisconsin Department of Transportation, GRANTEE, for the sum of **Five Hundred and 00/100 Dollars (\$500.00)**

Any person named in this easement may make an appeal from the amount of compensation within six months after the date of recording of this easement as set forth in s.32.05(2a) Wisconsin statutes. For the purpose of any such appeal, the amount of compensation stated on the easement shall be treated as the award, and the date the easement is recorded shall be treated as the date of taking and the date of evaluation.

Other persons having an interest of record in the property: None

This is not homestead property.

LEGAL DESCRIPTION IS ATTACHED AND MADE A PART OF THIS DOCUMENT BY REFERENCE.

This space is reserved for recording data

Return to
Teri Weil
TerraVenture Advisors, LLC
PO Box 110
Baraboo, WI 539313

Parcel Identification Number/Tax Key Number
030-1091-00000

The undersigned certify that this instrument is being executed pursuant to a resolution of the board of directors (or shareholders, if authorized by law) of County of Sauk of the State of Wisconsin.

FOR: Sauk County

Signature Date

Print Name

Signature Date

Print Name

Signature Date

Print Name

Signature Date

Print Name

Date

State of Wisconsin

Sauk)
County) ss.

On the above date, this instrument was acknowledged before me by the named person(s).

Signature, Notary Public, State of Wisconsin

Print Name, Notary Public, State of Wisconsin

Date Commission Expires

431



Project ID
5080-09-23

This instrument was drafted by
Wisconsin Department of Transportation

Parcel No.
11

LEGAL DESCRIPTION

Parcel 11 of Transportation Project Plat 5080-09-23 - 4.04 recorded in Transportation Project Plats, as Document No. 1247192, recorded in Sauk County, Wisconsin.

Property interests and rights of said Parcel 11 consist of:

Easement for highway purposes

STATEMENT TO CONSTRUCTION ENGINEER

RE1528 01/2023 s. 84.09 Wis. Stats.

Wisconsin Department of Transportation

Copies to: project engineer and owner

Owner Name(s) Sauk County	Property Address	Area code - phone
	Mailing Address	Home:
Tenant, if any	Property Address	Cell:
	Mailing Address	Work:
		Email:

Commitments made (fences, driveways, trees, drainage or other items):

Other matters of interest and owner concerns:

Property Owner Signature	Date	Negotiator Signature	Date
Property Owner Signature	Date	Print Negotiator Name	

Commitments Approved:

Approving Authority Signature and Title	Date
Print Approving Authority Name	



Project ID
5080-09-23

County
Sauk
433

Parcel No.
11

TRANSPORTATION PROJECT PLAT NO: 5080-09-23 - 4.04
PART OF THE NW¼-SW¼ OF SECTION 34, TOWNSHIP 12 NORTH, RANGE 4 EAST, TOWN OF REEDSBURG, SAUK COUNTY, WISCONSIN.

RELOCATION ORDER STH 23, SPRING GREEN - REEDSBURG, ELDER RIDGE ROAD TO CTH K, SAUK COUNTY

TO PROPERLY LOCATE, LAY OUT, WIDEN, ENLARGE, EXTEND, CONSTRUCT, RECONSTRUCT, IMPROVE, OR MAINTAIN A PORTION OF THE HIGHWAY DESIGNATED ABOVE, THE STATE OF WISCONSIN DEPARTMENT OF TRANSPORTATION DEEMS IT NECESSARY TO RELOCATE OR CHANGE SAID HIGHWAY AND ACQUIRE CERTAIN LANDS AND INTERESTS IN LANDS FOR THE ABOVE NAMED PROJECT.

TO EFFECT THIS CHANGE, PURSUANT TO AUTHORITY GRANTED UNDER SECTION 84.02 (5), 84.03, AND 84.30, WISCONSIN STATUTES, THE DEPARTMENT OF TRANSPORTATION HEREBY ORDERS THAT:

1. THAT PORTION OF SAID HIGHWAY AS SHOWN ON THIS PLAT IS LAY OUT AND ESTABLISHED TO THE LINES AND WIDTHS AS SO SHOWN FOR THE ABOVE NAMED PROJECT.
2. THE LANDS OR INTERESTS OR RIGHTS IN LANDS AS SHOWN ON THIS PLAT ARE REQUIRED BY THE DEPARTMENT FOR THE ABOVE PROJECT AND SHALL BE ACQUIRED IN THE NAME OF THE STATE OF WISCONSIN, PURSUANT TO THE PROVISIONS OF SUBSECTION 84.09 (1) OF SAID WISCONSIN STATUTES.

FOR CURRENT ACCESSORY WAY INFORMATION, CONTACT THE PLANNING UNIT OF THE WISCONSIN DEPARTMENT OF TRANSPORTATION OFFICE IN LA CROSSE

POSITIONS SHOWN ON THIS PLAT ARE WISCONSIN COORDINATE REFERENCE SYSTEM COORDINATES (WCSRS, SAUK COUNTY, NAD 83 (2011), IN US SURVEY FEET. VALUES SHOWN ARE GRID COORDINATES, GRID BEARINGS, AND GRID DISTANCES. GRID DISTANCES MAY BE USED AS GROUND DISTANCES.

EXISTING 3 IN. 23 HIGHWAY RIGHT-OF-WAY SHOWN HEREIN IS BASED ON THE FOLLOWING POINTS OR REFERENCE: RIGHT-OF-WAY PLAT DIVISION JOB NO. 1628

ALL NEW RIGHT-OF-WAY MONUMENTS WILL BE TYPE 2 (TYPICALLY 7" x 2" IRON REBAR), UNLESS OTHERWISE NOTED, AND WILL BE PLACED PRIOR TO THE COMPLETION OF THE PROJECT FOR ADDITIONAL INFORMATION REFER TO THE TITLE SHEET, REQUIRED BY THE OFFICE OF REGISTER OF DEEDS IN SAUK COUNTY AS SHEET 2 OF 2 OF DOCUMENT 1246268.

DOCUMENT # 1246268
ISSUED 09/02/2024 BY SAUK COUNTY REGISTER OF DEEDS
REGISTERED UNDER THE
RECORDS FOR RECORD
PLAT NUMBER 5080-09-23-4.04
This document has been filed electronically.

APPROVED FOR RECORD BY SAUK COUNTY REGISTER OF DEEDS
PROJECT NUMBER 5080-09-23-4.04

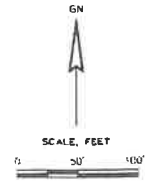

PLAT SCALE - 1" = 50'-0"

PLAT NO. 5080-09-23-4.04

PLAT DATE: 09-02-2024 11:07 AM

FILE NAME: 5080-09-23-4.04 - County\WORKING\5080-09-23-4.04.dwg
APPRAISED: 09/02/2024

TOWN OF REEDSBURG
NE¼-SE¼

REEDSBURG

NW¼-SW¼

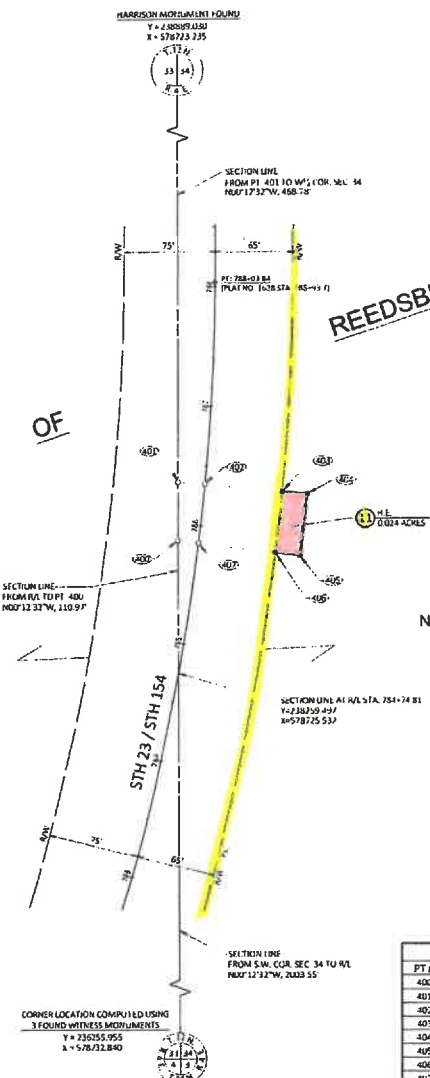

ALIGNMENT SUB-CURVE

PC	578725.127
PVI	578725.127
PT	578725.127
LC	150.00'
EA	150.00'

ALIGNMENT SUB-CURVE

PC	578725.127
PVI	578725.127
PT	578725.127
LC	150.00'
EA	150.00'

ALIGNMENT SUB-CURVE

PC	578725.127
PVI	578725.127
PT	578725.127
LC	150.00'
EA	150.00'

RIGHT OF WAY COURSE TABLE

POINT TO POINT	BEARING	DISTANCE
400 TO 401	N07°12'37"W	49.79'
403 TO 402	S84°40'32"E	22.22'
402 TO 403	S84°40'32"E	65.00'
403 TO 404	S84°40'32"E	20.00'
404 TO 405	S26°04'28"W	52.22'
405 TO 406	N83°10'32"W	20.00'
406 TO 407	N83°10'32"W	65.00'
407 TO 408	N83°10'32"W	16.77'

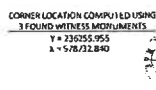

R/W POINTS

PT #	STATION	OFFSET	Y	X
400	785+85.00	10.77' LT	238870.464	578725.127
401	785+85.00	17.22' LT	238880.251	578724.945
402	785+85.00	0.00'	238818.169	578724.084
403	785+85.00	65.00' RT	238812.158	578721.750
404	785+85.00	65.00' RT	238810.207	578721.658
405	785+85.00	65.00' RT	238818.371	578726.171
406	785+85.00	65.00' RT	238860.459	578806.368
407	785+85.00	0.00'	238868.472	578761.274

SCHEDULE OF LANDS & INTERESTS REQUIRED

PARCEL NUMBER	OWNER(S)	INTERESTS	HE. REQUIRED	ACRES	TILE
203	FRONTIER COMMUNICATIONS	RELEASE OF RIGHTS	100%	0.0000	11

NOTE: OWNER'S NAMES ARE SHOWN FOR REFERENCE PURPOSES ONLY AND ARE SUBJECT TO CHANGE PRIOR TO THE TRANSFER OF LAND INTERESTS TO THE DEPARTMENT.

UTILITY INTERESTS REQUIRED

UTILITY NUMBER	OWNER(S)	INTEREST REQUIRED
203	FRONTIER COMMUNICATIONS	RELEASE OF RIGHTS

UTILITY EASEMENT TABLE

UTILITY NUMBER	OWNER & RECORDING INFORMATION	LOCATED IN R/W PARCEL #
203	GENERAL TRUST COMPANY OF WISCONSIN 200 W. WISCONSIN ST., SUITE 200, WISCONSIN	11

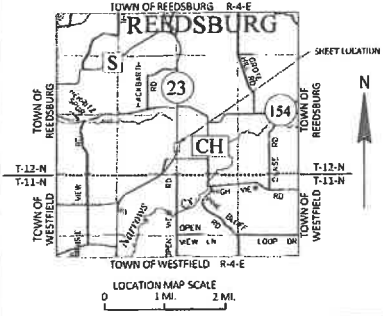

JEWELL
INCORPORATED
Engineers - Architects - Surveyors

I, NOME E. ANERUM, PROFESSIONAL LAND SURVEYOR, HEREBY CERTIFY THAT I HAVE FULLY COMPLIANCE WITH THE PROVISIONS OF SECTION 84.09(5) OF THE WISCONSIN STATUTES AND UNDER THE DIRECTION OF THE DEPARTMENT OF TRANSPORTATION, I HAVE SURVEYED AND MAPPED THIS TRANSPORTATION PROJECT PLAT AND SULL PLAT CORRECTLY PURSUANT TO ALL APPLICABLE PROVISIONS OF THE SUPPORTING LAWS.

SIGNATURE: *NOME E. ANERUM* DATE: 09/02/2024
POINT NAME: NOME E. ANERUM
REGISTRATION NUMBER: S-3355

THIS PLAT AND RELOCATION ORDER ARE APPROVED FOR THE DEPARTMENT OF TRANSPORTATION

SIGNATURE: *Cory Schaefer* DATE: 09/02/2024
POINT NAME: CORY SCHAEFER

1
2
3
4
5
6
7
8
9
10
11
12
13
14
15
16
17
18
19
20
21
22
23
24

RESOLUTION # 4 -2024

AMENDING THE 2024 BUDGET TO APPROPRIATE \$90,259 PURSUANT TO AN INTERGOVERNMENTAL AGREEMENT BETWEEN SAUK COUNTY, WISCONSIN AND THE HO-CHUNK NATION

Resolution offered by the Finance Committee

Resolved by the Board of Supervisors of Sauk County, Wisconsin:

BACKGROUND: On April 20, 2010 by Resolution 43-10, Sauk County was authorized to enter into an intergovernmental agreement with the Ho-Chunk Nation that provides for an annual payment of \$90,259 from the Ho-Chunk Nation to Sauk County. These funds may be used at the County's discretion for any purpose unless that purpose is considered a prohibited purpose that diminishes the Nation's governmental jurisdiction or has an adverse financial impact on the Nation. The County may not spend any money received under this agreement until the County provides a written report to the Nation each March 1; and the Nation must expressly state that the intended use does not constitute a prohibited purpose, or 30 days must have elapsed since the Nation has received said report and the Nation has not objected.

WHEREAS, the adoption of the 2024 County budget allocated \$57,879 of the \$90,259 Ho-Chunk annual payment;

Administrator	Indigenous People's Day Celebration	\$10,000
Aging & Disability Resource Center	Breakfast Bag Program	15,500
Highway	Highway Maintenance	32,379
	2024 Budgeted Ho-Chunk funds	\$57,879

25
26
27
28
29

NOW, THEREFORE BE IT RESOLVED, by the Sauk County Board of Supervisors that the 2024 budget is hereby amended to appropriate the remaining 2024 Ho-Chunk funds of \$32,380 as follows:

Land Resources & Environment	Hemlock Park Design/Develop ADA fishing opportunities.	\$26,880
Public Health	Safe Sleep Cribs	3,000
Public Health	County Resident Survey-Resident Access Information Survey	2,500
	2024 Total Allocated Ho-Chunk funds	\$90,259

30
31
32
33
34
35
36
37
38
39
40

For Consideration by the Sauk County Board of Supervisor on January 16, 2024.

Consent Agenda Item: [] YES [X] NO





Fiscal Impact: [] None [] Budgeted Expenditure [X] Not Budgeted

Vote Required: Majority = _____ 2/3 Majority = X 3/4 Majority = _____

The County Board has the legal authority to adopt: Yes X No _____ as reviewed by the Corporation Counsel, , Date: 01.10.2024.

41
42
43
44
45
46
47
48
49
50
51
52
53
54
55
56
57
58
59
60
61
62
63
64
65
66
67
68
69
70

Offered and passage moved by **Finance Committee**:

 Marty Krueger	<input checked="" type="checkbox"/> Aye	<input type="checkbox"/> Nay	<input type="checkbox"/> Abstain	<input type="checkbox"/> Absent
 Richard "Mike" Flint	<input checked="" type="checkbox"/> Aye	<input type="checkbox"/> Nay	<input type="checkbox"/> Abstain	<input type="checkbox"/> Absent
 Lynn Eberly	<input checked="" type="checkbox"/> Aye	<input type="checkbox"/> Nay	<input type="checkbox"/> Abstain	<input type="checkbox"/> Absent
 Thomas Dorner	<input checked="" type="checkbox"/> Aye	<input type="checkbox"/> Nay	<input type="checkbox"/> Abstain	<input type="checkbox"/> Absent
 Timothy McCumber	<input checked="" type="checkbox"/> Aye	<input type="checkbox"/> Nay	<input type="checkbox"/> Abstain	<input type="checkbox"/> Absent

Fiscal Note: To avoid supplanting the property tax and creating undue reliance on this potentially non-recurring and non-discretionary funding stream, these dollars were purposefully not included in the original 2024 budget. *JMA*

MIS Note: No impact.

MINUTES

SAUK COUNTY BOARD OF SUPERVISORS

FEBRUARY 20, 2024

WEST SQUARE BUILDING, 505 BROADWAY, ROOM 326, BARABOO, WI

REGULAR MEETING: SAUK COUNTY BOARD OF SUPERVISORS

1. Call to Order and Certify Compliance with Open Meeting Law: 6:00 P.M.

2. Roll Call. PRESENT: (27) Roxen, T. Spencer, Eberl, Kinsman, Klitzke, Scanlon, Anderson, Krueger, Flint, Clemens, Lombard, Schell, Dorner, Fordham, Astle, Hazard, R. Spencer, Carver, Burchill, Peper, Lohr, Gruber, Detter, Stehling, McAuliffe, Deitrich and McCumber. VIRTUAL: (3) Prosser, Polivka and Chrisler.
ABSENT & EXCUSED: (1) Rego.

Staff Present: Brent Miller, County Administrator; Brian Desmond, Corporation Counsel; Becky Evert, Sauk County Clerk; Cora McDonnell, Deputy County Clerk; and Chris Harry, Deputy County Clerk.

3. Invocation and Pledge of Allegiance. Invocation given by Supervisor Clemens.

4. Adopt Agenda. MOTION (Schell/Dorner) to adopt agenda.

The following scrivener error was noted:

Resolution 6-2024: lines 25-27 "BE IT FURTHER RESOLVED, that the Chairperson of the Sauk County Board of Supervisors is hereby directed to present ~~Robert Bonham~~ *Parrish Helms* an appropriate certificate and commendation as a token of our esteem."

Motion carried **unanimously**.

5. Adopt the minutes. MOTION (Carver/Roxen) to adopt the minutes from the previous meeting.

Motion carried **unanimously**.

6. General Consent Agenda Items.

a. LAW ENFORCEMENT AND JUDICIARY COMMITTEE:

i. Resolution 5-2024 To Honor Michael Cook For 16 Years Of Service.

b. HIGHWAY COMMITTEE:

i. Resolution 6-2024 To Honor Parrish Helms For Over 17 Years Of Faithful Service To The People Of Sauk County.

ii. Resolution 7-2024 To Honor Robert Bonham For Over 36 Years Of Faithful Service To The People Of Sauk County.

MOTION (Klitzke/Scanlon) to approve all General Consent Agenda item. Motion carried **unanimously**.

7. Scheduled Appearances. None.

8. Public Comment.

a. Nancy Thome, re: Election

b. Tom Kriegl, re: Health Care Center

9. Communications.

- a. 01/12/2024 Email from Western Technical College District Board, re: Vacancy Notice.
- b. 01/19/2024 Letter from Madison Area Technical College, re: Notice Of Intent To Appoint District Board Members.
- c. 01/29/2024 Email from Western Technical College District Board Appointment Committee, re: Public Hearing & Meeting Date.
- d. 02/01/2024 Letter from Jim & Judy Garske, re: Sauk County Health Care Center (SCHCC).
- e. 02/15/2024 Email from Western Technical College, re: Candidates Requesting Consideration For Re/Appointment.

10. Appointments.

a. Families Come First/Comprehensive Community Services Coordinating Committee:

- i. Amy Breunig, Re-Appointment, Citizen Member
3– year term: 02/20/2024-02/16/2027
- ii. Julie Eckert, Re-Appointment, Citizen Member
3– year term: 02/20/2024-02/16/2027
- iii. Ryan Catterson, Re-Appointment, Citizen Member
3– year term: 02/20/2024-02/16/2027

b. Children’s Community Options Program/Birth to 3 Advisory Committee:

- i. Greg Gintz, Re-Appointment, Citizen Member
3– year term: 02/20/2024-02/16/2027
- ii. Roberta Kasper, Re-Appointment, Citizen Member
3– year term: 02/20/2024-02/16/2027

c. Veteran’s Service Commission:

- i. Carl Oppert, Re-Appointment, Citizen Member
3– year term: 02/20/2024-02/16/2027

d. Sauk County Board of Health Committee:

- i. Eleanor O. Vita, M.D., New Appointment, Citizen Member
3– year term: 02/20/2024-02/16/2027

e. Sauk County Health Care Center, Nursing Home Administrator:

- i. Emily Greenwood-Flock

MOTION (T. Spencer/Gruber) to approve all appointments. *(Voice Vote)*

AYES: (26) Roxen, T. Spencer, Eberl, Kinsman, Scanlon, Anderson, Krueger, Flint, Clemens, Lombard, Schell, Dorner, Fordham, Astle, Hazard, R. Spencer, Carver, Burchill, Peper, Lohr, Gruber, Detter, Stehling, McAuliffe, Deitrich and McCumber. NAYS: (1) Klitzke. VIRTUAL AYES: (3) Prosser, Polivka, and Chrisler. ABSENT & EXCUSED: (1) Rego. Motion carried.

11. **Bills.** None.

12. **Claims.** None.

13. **Elections.** None.

14. **Proclamations.** None.

15. **Reports – informational, no action required.**

- a. Rebecca C. Evert, Sauk County Clerk – Rezoning petitions filed with the office of the Sauk County Clerk as a requirement of Wisconsin State Statutes 59.69(5)(e): None.
- b. Brent Miller
 - i. Administrator’s report.
- c. Tim McCumber, County Board Chair
 - i. Board Chair Update.

16. **Unfinished Business. None.**

17. **New Business.**

FINANCE COMMITTEE:

Resolution 8-2024 Designating County Depositories; Establishing Investment And Related Financial Procedures. MOTION (Krueger/Dorner). **VOTE:** AYES: (27) Roxen, T. Spencer, Eberl, Kinsman, Klitzke, Scanlon, Anderson, Krueger, Flint, Clemens, Lombard, Schell, Dorner, Fordham, Astle, Hazard, R. Spencer, Carver, Burchill, Peper, Lohr, Gruber, Detter, Stehling, McAuliffe, Deitrich and McCumber. NAYS: (0). VIRTUAL AYES: (2) Polivka and Chrisler. DID NOT VOTE: (1) Prosser. ABSENT & EXCUSED: (1) Rego. Motion carried **unanimously**.

PROPERTY COMMITTEE:

Resolution 9-2024 Authorizing To Contract With The City Of Baraboo For Patrolling And Ticketing Unauthorized Parking Overnight In The West Square Parking Lot. MOTION (Detter/Gruber).

Several Scrivener’s Errors were noted:

Resolution 9-2024: several lines throughout the proposed Revenue and Enforcement Agreement Between Sauk County and the City of Baraboo.

VOTE: AYES: (27) Roxen, T. Spencer, Eberl, Kinsman, Klitzke, Scanlon, Anderson, Krueger, Flint, Clemens, Lombard, Schell, Dorner, Fordham, Astle, Hazard, R. Spencer, Carver, Burchill, Peper, Lohr, Gruber, Detter, Stehling, McAuliffe, Deitrich and McCumber. NAYS: (0). VIRTUAL AYES: (3) Prosser, Polivka and Chrisler. ABSENT & EXCUSED: (1) Rego. Motion carried **unanimously**.

Resolution 10-2024 To Authorize A Contract With A Real Estate Broker For The Sauk County Health Care Center. MOTION (Detter/Gruber). **VOTE:** AYES: (22) Roxen, T. Spencer, Eberl, Kinsman, Klitzke, Scanlon, Anderson, Clemens, Lombard, Schell, Dorner, Astle, R. Spencer, Carver, Burchill, Peper, Lohr, Gruber, Detter, Stehling, Deitrich and McCumber. NAYS: (5) Krueger, Flint, Fordham, Hazard, McAuliffe. VIRTUAL AYES: (3) Prosser, Polivka and Chrisler. ABSENT & EXCUSED: (1) Rego. Motion carried.

HIGHWAY COMMITTEE:

Resolution 11-2024 To Enter Into A Memorandum Of Understanding (MOU) For The Construction Of A Drainage Ditch In The Town Of Spring Green And Village Of Spring Green. MOTION (Peper/Gruber).

**Jed Siedl, Sauk County Emergency Management Directory and Pat Gavinski, Sauk County Highway Commissioner gave board an overview of the proposed Resolution 11-2024.*

The following scrivener’s errors were noted:

Resolution 11-2024: lines 13-16 “This MOU would ~~commit~~ commit Sauk County, the Village of Spring Green, and the Town of Spring Green to fund the local share of a Building Resilient Infrastructure and Communities (BRIC) grant. The BRIC ~~grant~~ grant will fund 75% of the total project cost.”

MOTION (Peper/Gruber). VOTE: AYES: (27) Roxen, T. Spencer, Eberl, Kinsman, Klitzke, Scanlon, Anderson, Krueger, Flint, Clemens, Lombard, Schell, Dorner, Fordham, Astle, Hazard, R. Spencer, Carver, Burchill, Peper, Lohr, Gruber, Detter, Stehling, McAuliffe, Deitrich and McCumber. NAYS: (0).

VIRTUAL AYES: (3) Prosser, Polivka and Chrisler. ABSENT & EXCUSED: (1) Rego. Motion carried **unanimously.**

HIGHWAY AND FINANCE COMMITTEE:

Resolution 12-2024 To Amend The 2024 Budget For Allocation Of ARPA Funds For Grant Writing Seeking Funding For The Construction Of A Drainage Ditch In The Town Of Spring Green And Village Of Spring Green. MOTION (Peper/Polivka).

The following scrivener error was noted:

Resolution 12-2024: line 54 "~~Keven~~ Kevin Schell".

VOTE: AYES: (27) Roxen, T. Spencer, Eberl, Kinsman, Klitzke, Scanlon, Anderson, Krueger, Flint, Clemens, Lombard, Schell, Dorner, Fordham, Astle, Hazard, R. Spencer, Carver, Burchill, Peper, Lohr, Gruber, Detter, Stehling, McAuliffe, Deitrich and McCumber. NAYS: (0). VIRTUAL AYES: (3) Prosser, Polivka and Chrisler. ABSENT & EXCUSED: (1) Rego. Motion carried **unanimously.**

18. Referrals.

19. **New Agenda items (no discussion). Submit in writing or by e-mail new business items to the County Administrator as soon as possible for Rule III.A. referral.**

20. **Adjournment to a date certain: 6:48 P.M. MOTION (Lohr/Carver) to adjourn until Tuesday, March 19, 2024, at 6:00 P.M. Motion carried **unanimously**.**

Respectfully submitted,

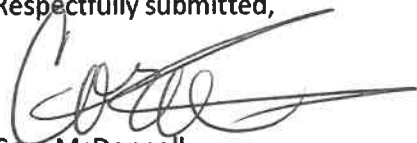

Cora McDonnell
Deputy County Clerk

Minutes Approved: March 19, 2024.

State of Wisconsin, County of Sauk: I certify that the above is a true and correct copy of the February 20, 2024. Proceedings of the Sauk County Board of Supervisors.

/s/Rebecca C. Evert, Sauk County Clerk.

Original documents on file @ Office of the Sauk County Clerk West Square Building, 505 Broadway, Room #144, Baraboo, WI 53913. Office Phone: 608-355-3286.

www.co.sauk.wi.us

These notices may also be found at: <http://www.wisconsinpublicnotices.org/> or <https://www.co.sauk.wi.us/legalnotices>.

RESOLUTION # 5-2024

Resolution to Honor Michael Cook for 16 Years of Service

Resolution offered by the Law Enforcement and Judiciary Committee
Resolved by the Board of Supervisors of Sauk County, Wisconsin:

BACKGROUND: It is custom of the Sauk County Board of Supervisors to recognize staff members who have served the people of Sauk County with distinction. Michael Cook faithfully served the people of Sauk County for the Sauk County Sheriff's Office. Michael started on February 25, 2008 as a Jail Deputy where he remained and retired as of January 4, 2024.

THEREFORE, BE IT RESOLVED, that the Sauk County Board of Supervisors, met in regular session, hereby expresses its appreciation and commends Michael Cook for 16 years of faithful service to the people of Sauk County; and

BE IT FURTHER RESOLVED, that the Chairperson of the Sauk County Board of Supervisors is hereby directed to present Michael Cook an appropriate certificate and commendation as a token of our esteem.

Approved for presentation to the County Board by the Law Enforcement & Judiciary Committee, this 20th day of February, 2024.

Consent Agenda Item: [X] YES [] NO

Fiscal Impact: [X] None [] Budgeted Expenditure [] Not Budgeted

Vote Required: Majority = X 2/3 Majority = _____ 3/4 Majority = _____

The County Board has the legal authority to adopt: Yes 100 No _____ as reviewed by the Corporation Counsel, [Signature], Date: 02.15.2024.

Offered and passage moved by:

[Signature] Aye Nay Abstain Absent
John Deitrich

[Signature] Aye Nay Abstain Absent
Kevin Schell

[Signature] Aye Nay Abstain Absent
David Clemens

[Signature] Aye Nay Abstain Absent
Sheila Carver

[Signature] Aye Nay Abstain Absent
Delmar Scanlon

Fiscal Note: No Impact It
MIS Note: No Impact

RESOLUTION # 6-2024

Resolution to Honor Parrish Helms for over 17 years of Faithful Service to the People of Sauk County

Resolution offered by the Highway Committee
Resolved by the Board of Supervisors of Sauk County, Wisconsin:

BACKGROUND: It is custom of the Sauk County Board of Supervisors to recognize staff members who have served the people of Sauk County with distinction. Parrish faithfully served the people of Sauk County for the Highway Department. Parrish started on October 30, 2006 as a Patrolman for the Highway Department. Parrish later moved to a Skilled Laborer position and then went on to be a Skilled equipment operator and then a Highway Operator 2. Parrish maintained professional and ethical integrity while serving the County. Parrish was an essential team member to the Highway Department and all of Sauk County.

THEREFORE, BE IT RESOLVED, that the Sauk County Board of Supervisors, met in regular session, hereby expresses its appreciation, and commends Parrish Helms for over 17 years of faithful service to the people of Sauk County; and

BE IT FURTHER RESOLVED, that the Chairperson of the Sauk County Board of Supervisors is hereby directed to present Robert Bonham an appropriate certificate and commendation as a token of our esteem.

Approved for presentation to the County Board by the Highway Committee, this 20th day of February 2024.

Consent Agenda Item: [X] YES [] NO

Fiscal Impact: None [] Budgeted Expenditure [] Not Budgeted

Vote Required: Majority = X 2/3 Majority = _____ 3/4 Majority = _____

The County Board has the legal authority to adopt: Yes BTD No _____ as reviewed by the Corporation Counsel, [Signature] , Date: 02-15, 2024 .

Offered and passage moved by:

[Signature] Aye Nay Abstain Absent
Brian Peper

[Signature] Aye Nay Abstain Absent
Terry Spencer

[Signature] Aye Nay Abstain Absent
Smooth Dettler

[Signature] Aye Nay Abstain Absent

56
57
58
59
60
61
62
63
64

Mike Flint

Kevin Schell

Aye Nay Abstain Absent

Fiscal Note: 

MIS Note:

RESOLUTION # 7-2024

Resolution to Honor Robert Bonham for over 36 years of Faithful Service to the People of Sauk County

Resolution offered by the Highway Committee

Resolved by the Board of Supervisors of Sauk County, Wisconsin:

BACKGROUND: It is custom of the Sauk County Board of Supervisors to recognize staff members who have served the people of Sauk County with distinction. Rob faithfully served the people of Sauk County for the Highway Department. Rob started on May 18, 1987 as a LTE for the Highway Department. Rob was hired on fulltime in 1990 as a Patrolman's Helper and then went on to be a Patrolman and then a Patrol Superintendent. Rob maintained professional and ethical integrity while serving the County. Rob was an essential team member to the Highway Department and all of Sauk County.

THEREFORE, BE IT RESOLVED, that the Sauk County Board of Supervisors, met in regular session, hereby expresses its appreciation, and commends Robert Bonham for over 36 years of faithful service to the people of Sauk County; and

BE IT FURTHER RESOLVED, that the Chairperson of the Sauk County Board of Supervisors is hereby directed to present Robert Bonham an appropriate certificate and commendation as a token of our esteem.

Approved for presentation to the County Board by the Highway Committee, this 20th day of February 2024.

Consent Agenda Item: [X] YES [] NO

Fiscal Impact: [X] None [] Budgeted Expenditure [] Not Budgeted

Vote Required: Majority = X 2/3 Majority = 3/4 Majority =

The County Board has the legal authority to adopt: Yes X No as reviewed by the Corporation Counsel, [Signature], Date:

Offered and passage moved by:

[Signature] Aye Nay Abstain Absent
Brian Peper

[Signature] Aye Nay Abstain Absent
Terry Spencer

[Signature] Aye Nay Abstain Absent
Smooth Detter

54
55
56
57
58
59
60
61
62
63



Mike Flint

Aye Nay Abstain Absent



Kevin Schell

Aye Nay Abstain Absent

Fiscal Note: 

MIS Note:

RESOLUTION # 8-2024

DESIGNATING COUNTY DEPOSITORIES; ESTABLISHING INVESTMENT AND RELATED FINANCIAL PROCEDURES

Resolution offered by the Finance Committee

BACKGROUND:

§34.05 of the Wisconsin Statutes provides for the designation of official County depositories and the specification by County Boards of Supervisors of the basis upon which Treasurers shall be authorized to deposit and invest funds. The Sauk County Finance Committee has reviewed these and other financial matters and, in light of past practice and the best interest of Sauk County, does make the following recommendations as outlined in the resolution.

THEREFORE, BE IT RESOLVED, by the Sauk County Board of Supervisors, met in regular session, that the Sauk County Treasurer shall deposit County funds as provided under the statutes of the State of Wisconsin, County Financial Policy 10-95, and this resolution, emphasizing preservation of principal, liquidity and rate of return; and,

BE IT FURTHER RESOLVED, that Sauk County participate in the State of Wisconsin's Local Government Investment Pool pursuant to §25.50 of the Wisconsin Statutes, with the Sauk County Treasurer or authorized deputies hereby designated as the "local official" authorized to invest County monies in this fund and to make withdrawals therefrom as required; and,

BE IT FURTHER RESOLVED, that the Sauk County Treasurer shall be authorized to maintain a working or active checking account for the immediate operation of Sauk County in any financial institution that is a member of Federal Deposit Insurance Corporation and under the State of Wisconsin deposit guarantee program if applicable. The financial institution must be conveniently located for conducting daily business; and,

BE IT FURTHER RESOLVED, that pursuant to §34.09 of the Wisconsin Statutes, every federal or state credit union, state bank, federal or state savings and loan association, savings and trust company and federal or state savings bank and every national bank may be designated as a public depository and may receive and hold public deposits, subject to the referenced chapter, if the financial institution has a branch or main office located in this state, complies with this chapter with respect to public deposits and accepts payments made by the state under §16.412 of the Wisconsin Statutes; and,

BE IT FURTHER RESOLVED, that the Sauk County Treasurer or authorized deputies shall be responsible for obtaining the appropriate collateralization agreements to guarantee the safety of Sauk County funds in excess of insured or guaranteed limits. This pledge of collateral for deposits must follow the Governmental Accounting Standards Board requirements; and,

BE IT FURTHER RESOLVED, that all County officers and all other County personnel receiving or handling County funds shall deposit monies at least weekly with the Sauk County Treasurer or in other appropriate authorized accounts. The list below reflects institutions that currently contain County funds. The Sauk County Treasurer may make changes or additions to these institutions which are approved by the Finance Committee; and,

- | | |
|----------------------------|---------------------------------------|
| Bank of Prairie du Sac | PMA Financial Network, Inc |
| Bank of Wisconsin Dells | PNC Bank |
| Baraboo State Bank | Prevail Bank |
| Community First Bank | Wells Fargo Bank, N.A. |
| Farmers & Merchants Bank | Wisc Investment Service Cooperative |
| First Business Bank | Wisc Local Government Investment Pool |
| The Peoples Community Bank | Westby Co-Op Credit Union |

53
54
55
56
57
58
59
60
61
62
63
64
65
66
67
68
69
70
71
72
73
74
75
76
77
78
79
80
81
82
83
84
85
86
87
88
89
90
91
92
93
94
95

BE IT FURTHER RESOLVED, that all general and payroll County checks shall bear the facsimile signatures of the Sauk County Clerk, the Sauk County Treasurer, and the Sauk County Board Chairperson. Any other checks issued by Sauk County departments shall bear the signature, either original or facsimile, of that department's administrator or their designee.

For consideration by the Sauk County Board of Supervisors on February 20, 2024.

Approved for presentation to the County Board by the Finance Committee, this 5th day of February, 2024

Consent Agenda Item: [] YES [X] NO

Fiscal Impact: [] None [X] Budgeted Expenditure [] Not Budgeted

Vote Required: Majority = _____ 2/3 Majority = X 3/4 Majority = _____

The County Board has the legal authority to adopt: Yes 300 No _____ as reviewed by the Corporation Counsel, [Signature], Date: Feb. 14, 2024

Offered and passage moved by:

- | | | | | |
|---|---|------------------------------|----------------------------------|---------------------------------|
| <u>[Signature]</u>
Martin F. Krueger, Chairperson | <input checked="" type="checkbox"/> Aye | <input type="checkbox"/> Nay | <input type="checkbox"/> Abstain | <input type="checkbox"/> Absent |
| <u>[Signature]</u>
Lynn A. Eberl, Vice-Chairperson | <input checked="" type="checkbox"/> Aye | <input type="checkbox"/> Nay | <input type="checkbox"/> Abstain | <input type="checkbox"/> Absent |
| <u>[Signature]</u>
Richard M. Flint, Secretary | <input checked="" type="checkbox"/> Aye | <input type="checkbox"/> Nay | <input type="checkbox"/> Abstain | <input type="checkbox"/> Absent |
| <u>[Signature]</u>
Thomas Derner, Supervisor | <input checked="" type="checkbox"/> Aye | <input type="checkbox"/> Nay | <input type="checkbox"/> Abstain | <input type="checkbox"/> Absent |
| <u>[Signature]</u>
Timothy B McCumber, Supervisor | <input checked="" type="checkbox"/> Aye | <input type="checkbox"/> Nay | <input type="checkbox"/> Abstain | <input type="checkbox"/> Absent |

Fiscal Note: The Sauk County Treasurer shall deposit County funds as provided under the statutes of the State of Wisconsin, County Financial Policy 10-95, and this resolution,

[Handwritten mark]

96 emphasizing preservation of principal, liquidity and rate of return.
97
98 MIS Note: No MIS impact
99
100

RESOLUTION # 9-2024

Resolution Authorizing to contract with the City of Baraboo for patrolling and ticketing unauthorized parking overnight in the West Square Parking Lot

Resolution offered by the Property Committee

Resolved by the Board of Supervisors of Sauk County, Wisconsin:

BACKGROUND: The City of Baraboo conveyed to the County their interest in three parcels that make up approximately half of the parking lot for the West Square. As part of the conditions of the sale, the City of Baraboo would be allowed to enforce ordinances related to parking in the West Square Building Parking Lot and retain all related fines. The City of Baraboo has agreed to enact and enforce ordinances as listed in the attached agreement.

THEREFORE, BE IT RESOLVED THAT, the Sauk County Board of Supervisors, met in regular session, hereby approves the attached agreement with the City of Baraboo for the enactment and enforcement of parking regulations for the West Square Building Parking Lot.

Approved for presentation to the County Board by the Property Committee, this 1st day of February, 2024

Consent Agenda Item: [] YES [X] NO

Fiscal Impact: [X] None [] Budgeted Expenditure [] Not Budgeted

Vote Required: Majority = X 2/3 Majority = _____ 3/4 Majority = _____

The County Board has the legal authority to adopt: Yes 800 No _____ as reviewed by the Corporation Counsel, [Signature], Date: 02-14-2024.

Offered and passage moved by:

[Signature] Carl Gruber [X] Aye [] Nay [] Abstain [] Absent

[Signature] Mark "Smooth" Dettler [X] Aye [] Nay [] Abstain [] Absent

[Signature] Joel Chrisler [X] Aye [] Nay [] Abstain [] Absent

[Signature] Robert Spencer [X] Aye [] Nay [] Abstain [] Absent

[Signature] Jim Astle [X] Aye [] Nay [] Abstain [] Absent

Fiscal Note: No fiscal impact. MIS Note: No MIS impact.

REVENUE AND ENFORCEMENT AGREEMENT BETWEEN SAUK COUNTY AND THE CITY OF BARABOO

1. INTRODUCTION: This is an agreement between Sauk County ("County") and the City of Baraboo ("City") pursuant to Wis. Stat. § 66.0301 authorizing the enforcement of the City Ordinances pertaining to park parking restrictions at the County owned West Square Building parking lot. The Sauk County Board of Supervisors approved such enforcement on _____, by Resolution no. _____. The City of Baraboo Common Council approved this enforcement agreement on _____, by Resolution _____. Both parties agree that the undersigned are authorized to sign for their respective body. As such the parties hereby agree, in way of implementation, as follows:

2. SCOPE OF AGREEMENT: This agreement is meant to cover the West Square Building parking lot located in the City of Baraboo:

This agreement is meant only to apply to the enforcement of City ordinances for above referenced parking lot and is not intended to change or alter in any way the ownership, maintenance or upkeep of these parking lot or the surrounding property. The parties hereby agree that all normal maintenance and upkeep procedures and activities by the County shall be unaffected by this agreement and shall remain the responsibility of the County.

3. COLLECTION: The County hereby authorizes City, to enact and enforce parking ordinances according to officially adopted City ordinances. There shall be appropriate notice by way of signs at these locations notifying the public of these parking restrictions. All signs to be erected by the County. Any citations for violations of the City ordinances shall be the property of the City without any reimbursement to the County.

4. ENFORCEMENT: The City agrees to enforce the parking restrictions regarding the aforementioned West Square Building parking lot pursuant to the officially adopted City ordinances. The County shall identify those vehicles eligible for parking in the West Square Building by means of a sticker, sign or device affixed to each vehicle. County vehicles eligible to park in the West Square Building parking lot are intended to be used vehicles that are used on a regular basis the County. The spaces are not intended to be used to store vehicles that are non-operable or that are used on a seasonal basis.

All ordinance violations shall be processed by the City and all actions to prosecute these ordinance violations shall be taken by the City Attorney. The County shall have no responsibility or ability to prosecute violations City parking ordinances. This does not limit in any way their current ability to enforce their own County Ordinances.

5. LENGTH OF AGREEMENT: This agreement shall be in effect from the date of the last signature on this document and will renew every year, except that either party may terminate this agreement for any reason upon thirty (30) days' written notice via certified mail to:

County: Sauk County Clerk
 505 Broadway
 Baraboo, WI 53913

City: _____

[Signatures on following page]

BY SIGNING BELOW THE SIGNORS AFFIRM AND ACKNOWLEDGE THAT:

They have read and understand this contract and its Attachments, if any; they have authority to enter into this contract on behalf of the Entity, Corporation, or County they are signing for; they are knowingly, freely, and voluntarily entering into this contract and that they accept and agree to be bound by the terms and conditions of this contract.

COUNTY OF SAUK



Administrator, Sauk County

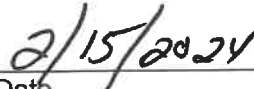

Date

CITY OF BARABOO

Administrator, City of Baraboo

Date

RESOLUTION # 10-2024

Resolution to Authorize a Contract with a Real Estate Broker for the Sauk County Health Care Center

Resolution offered by the Property Committee

Resolved by the Board of Supervisors of Sauk County, Wisconsin:

BACKGROUND:

Resolution 98-2023 authorized the Expansion of Long-Term Care Continuum in Sauk. This Resolution authorized using a Real Estate Broker to sell the Sauk County Health Care Center Facility (SCHCC). The Property Committee, at a January 9, 2024, meeting, directed the Administrator and Corporation Counsel put out a Request for Proposal for a Real Estate Broker to potentially sell the SCHCC. To do this Marcus & Millichap Real Estate Investment Services, Inc. (MMREIS) was selected based on their proven ability and price provided.

THEREFORE, BE IT RESOLVED, by the Sauk County Board of Supervisors that the Provision of Services by MMREIS at a fee of 3% be hereby approved.

BE IT FURTHER RESOLVED that the broker fees 3% will be taken from the net proceeds of the sale of the SCHCC.

Approved for presentation to the County Board by the Property Committee, this 20th day of February 2024

Consent Agenda Item: [] YES [X] NO

Fiscal Impact: [X] None [] Budgeted Expenditure [] Not Budgeted

Vote Required: Majority = X 2/3 Majority = _____ 3/4 Majority = _____

The County Board has the legal authority to adopt: Yes 800 No _____ as reviewed by the Corporation Counsel, [Signature], Date: 02-14-2024

Offered and passage moved by: Property Committee

Chair, Mark "Smooth" Dettler [] Aye [] Nay [] Abstain [] Absent

Supervisor Carl Gruber [] Aye [] Nay [] Abstain [] Absent

Supervisor Robert Spencer [] Aye [] Nay [] Abstain [] Absent

52
53
54
55
56
57
58
59
60
61
62
63

Supervisor Joel Chrisler

Aye Nay Abstain Absent

Supervisor James Astle

Aye Nay Abstain Absent

Fiscal Note: The Broker fees will be taken from the net proceeds of the sale of the SCHCC.

MIS Note: No Impact

RESOLUTION # 11-2024

Resolution to Enter into a Memorandum of Understanding (MOU) for the Construction of a Drainage Ditch in the Town of Spring Green and Village of Spring Green

Resolution offered by the Highway Committee

Resolved by the Board of Supervisors of Sauk County, Wisconsin:

BACKGROUND: The Highway Department is currently in the design phase of a reconstruction project Of CTH G in the Town of Spring Green. Potential funding is available to fund a portion of the road construction as well as a drainage ditch to alleviate drainage issues east of Pearl Rd. This MOU would committee Sauk County, the Village of Spring Green, and the Town of Spring Green to fund the local share of a Building Resilient Infrastructure and Communities (BRIC) grant. The BRIC grand will fund 75% of the total project cost. The project is scheduled to be constructed in 2027 if funding is awarded.

THEREFORE, BE IT RESOLVED, that the Sauk County Board of Supervisors, met in regular session, does hereby approve entering into the MOU.

Approved for presentation to the County Board by the Highway Committee, this 20th day of February, 2024

Consent Agenda Item: [] YES [X] NO

Fiscal Impact: [X] None [] Budgeted Expenditure [] Not Budgeted

Vote Required: Majority = X 2/3 Majority = 3/4 Majority =

The County Board has the legal authority to adopt: Yes BTD No as reviewed by the Corporation Counsel, [Signature], Date: 02.15.2024

Offered and passage moved by: Highway Committee

[Signature] Brian Peper [X] Aye [] Nay [] Abstain [] Absent

[Signature] Smooth Detter [X] Aye [] Nay [] Abstain [] Absent

[Signature] Terry Spencer [X] Aye [] Nay [] Abstain [] Absent

[Signature] Richard "Mike" Flint [X] Aye [] Nay [] Abstain [] Absent

[Signature] Keven Schell [X] Aye [] Nay [] Abstain [] Absent

52
53
54
55

Fiscal Note:
MIS Note:

ht

RESOLUTION # 12-2024

Resolution to amend the 2024 Budget for allocation of ARPA Funds for Grant Writing Seeking Funding for the Construction of a Drainage Ditch in the Town of Spring Green and Village of Spring Green

Resolution offered by the Highway Committee and Finance Committee

Resolved by the Board of Supervisors of Sauk County, Wisconsin:

BACKGROUND: The Highway Department is currently in the design phase of a reconstruction project Of CTH G in the Town of Spring Green. Potential funding is available to fund a portion of the road construction as well as a drainage ditch to alleviate drainage issues east of Pearl Rd. The requested ARPA funds would fund one third of the grant writing needed to apply for funds available through Wisconsin Emergency Management (WEM). The remaining two thirds would be funded by the Town of Spring Green and the Village of Spring Green. The cost of the County's share of the grant writing to apply for WEM funding is \$15,000. American Rescue Plan Funds(ARPA) are available for this project.

THEREFORE, BE IT RESOLVED, that the Sauk County Board of Supervisors, met in regular session, does hereby approve an amendment to the 2024 Budget to allocate an \$15,000 for grant writing funded by the ARPA grant.

Approved for presentation to the County Board by the Highway Committee and the Finance Committee, this 20th day of February, 2024

Consent Agenda Item: [] YES [X] NO

Fiscal Impact: [] None [] Budgeted Expenditure [X] Not Budgeted

Vote Required: Majority = _____ 2/3 Majority = X 3/4 Majority = _____

The County Board has the legal authority to adopt: Yes X No _____ as reviewed by the Corporation Counsel, [Signature], Date: 02.15.2024

Offered and passage moved by: Highway Committee

[Signature] Aye [] Nay [] Abstain [] Absent

Brian Peper

[Signature] Aye [] Nay [] Abstain [] Absent

Smooth Detter

[Signature] Aye [] Nay [] Abstain [] Absent

Terry Spencer

[Signature] Aye [] Nay [] Abstain [] Absent

Richard "Mike" Flint

52
53
54
55
56
57
58
59
60
61
62
63
64
65
66
67
68
69
70
71
72
73
74
75

_____ Aye Nay Abstain Absent
Keven Schell

Offered and passage moved by: Finance Committee

_____ Aye Nay Abstain Absent
Marty Krueger

_____ Aye Nay Abstain Absent
Richard "Mike" Flint

_____ Aye Nay Abstain Absent
Lynn Eberl

_____ Aye Nay Abstain Absent
Thomas Dorner

_____ Aye Nay Abstain Absent
Tim McCumber

Fiscal Note: The 2024 budget shall be amended to include an additional \$15,000 of ARPA funding. 

MIS Note:

MINUTES

SAUK COUNTY BOARD OF SUPERVISORS

MARCH 19, 2024

WEST SQUARE BUILDING, 505 BROADWAY, ROOM 326, BARABOO, WI

REGULAR MEETING: SAUK COUNTY BOARD OF SUPERVISORS

1. Call to Order and Certify Compliance with Open Meeting Law: 6:01 P.M.

2. Roll Call. PRESENT: (26) Roxen, T. Spencer, Eberl, Rego, Kinsman, Klitzke, Scanlon, Anderson, Krueger, Flint, Lombard, Dorner, Fordham, Astle, Hazard, R. Spencer, Carver, Polivka, Burchill, Peper, Lohr, Gruber, Detter, Stehling, Deitrich and McCumber. ABSENT & EXCUSED: (4) Clemens, Prosser, Schell, Chrisler. ABSENT: (1) McAuliffe.

Staff Present: Brent Miller, County Administrator; Brian Desmond, Corporation Counsel; Becky Evert, Sauk County Clerk; and Cora McDonnell, Deputy County Clerk.

3. Invocation and Pledge of Allegiance. Invocation given by Supervisor Rego.

4. Adopt Agenda. MOTION (Carver/Gruber) to adopt agenda. Motion carried **unanimously**. (*Voice Vote*)

**Supervisor McAuliffe arrived at 6:04PM*

5. Adopt the minutes. MOTION (Scanlon/T. Spencer) to adopt the minutes from the previous meeting. Motion carried **unanimously**. (*Voice Vote*)

6. General Consent Agenda Items.

a. **HEALTH CARE CENTER BOARD OF TRUSTEES:**

i. **Resolution 13-2024** To Commend Theresa Dietz For More Than 28 Years Of Faithful Service To The People Of Sauk County.

ii. **Resolution 14-2024** To Commend David Webber For More Than 15 Years Of Faithful Service To The People Of Sauk County.

MOTION (Klitzke/Rego) to approve all General Consent Agenda Items. Motion carried **unanimously**. (*Voice Vote*)

7. Scheduled Appearances. None.

8. Public Comment. None.

9. Communications. None.

10. Appointments.

a. **Families Come First/Comprehensive Community Services Coordinating Committee:**

i. Joanne Kitelinger, Re-Appointment, Citizen Member
2-year term: 03/19/2024 – 03/17/2026

b. **Children's Community Options Program/Birth to 3 Advisory Committee**

i. Robert King, Appointment, Citizen Member
3-year term: 03/19/2024 – 03/16/2027

MOTION (T. Spencer/Klitzke) to approve appointments. Motion carried **unanimously**. (*Voice Vote*)

- 11. **Bills.** None.
- 12. **Claims.** None.
- 13. **Elections.** None.
- 14. **Proclamations.** None.
- 15. **Reports – informational, no action required.**
 - a. Rebecca C. Evert, Sauk County Clerk – Rezoning petitions filed with the office of the Sauk County Clerk as a requirement of Wisconsin State Statutes 59.69(5)(e): None.
 - b. Brent Miller
 - i. Administrator’s Report.
 - c. Tim McCumber, County Board Chair
 - i. Board Chair Update.

16. **Unfinished Business.** None.

17. **New Business.**

FINANCE COMMITTEE:

Resolution 15-2024 Gratefully Accepting Donations And Gifts Presented To Sauk County In 2023.

MOTION (T. Spencer/Dorner). **VOTE:** AYES: (27) Roxen, T. Spencer, Eberl, Rego, Kinsman, Klitzke, Scanlon, Anderson, Krueger, Flint, Lombard, Dorner, Fordham, Astle, Hazard, R. Spencer, Carver, Polivka, Burchill, Peper, Lohr, Gruber, Detter, Stehling, McAuliffe, Deitrich and McCumber. NAYS: (0). ABSENT & EXCUSED: (4) Clemens, Prosser, Schell, Chrisler. Motion carried **unanimously**.

HIGHWAY COMMITTEE:

Resolution 16-2024 Designating The Week Of April 15th Through April 19th 2024 As “Workzone Safety Awareness Week In Sauk County”.

MOTION (Peper/Gruber). **VOTE:** AYES: (27) Roxen, T. Spencer, Eberl, Rego, Kinsman, Klitzke, Scanlon, Anderson, Krueger, Flint, Lombard, Dorner, Fordham, Astle, Hazard, R. Spencer, Carver, Polivka, Burchill, Peper, Lohr, Gruber, Detter, Stehling, McAuliffe, Deitrich and McCumber. NAYS: (0). ABSENT & EXCUSED: (4) Clemens, Prosser, Schell, Chrisler. Motion carried **unanimously**.

**Supervisor R. Spencer recused himself from the meeting.*

Ordinance 1-2024 Amendment To Sauk Co. Code Chapter 15 To Add All-Terrain Vehicle (ATV) And Utility-Terrain Vehicle (UTV) Crossings And Routes On County Highways.

MOTION (Peper/T. Spencer). **VOTE:** AYES: (26) Roxen, T. Spencer, Eberl, Rego, Kinsman, Klitzke, Scanlon, Anderson, Krueger, Flint, Lombard, Dorner, Fordham, Astle, Hazard, Carver, Polivka, Burchill, Peper, Lohr, Gruber, Detter, Stehling, McAuliffe, Deitrich and McCumber. NAYS: (0). ABSTAIN: (1) R. Spencer. ABSENT & EXCUSED: (4) Clemens, Prosser, Schell, Chrisler. Motion carried **unanimously**.

Ordinance effective upon passage pursuant to 59.02(2), of Wisconsin State Statutes (March 19, 2024).

**Supervisor R. Spencer rejoined the meeting.*

LAND RESOURCES & ENVIRONMENT COMMITTEE:

Resolution 17-2024 To Authorize Participation In The State Of Wisconsin Motorized Recreation Grant Programs For Snowmobile Trails, ATV/UTV Trails And Off-Highway Motorcycle Events.

MOTION (Polivka/Kinsman). VOTE: AYES: (27) Roxen, T. Spencer, Eberl, Rego, Kinsman, Klitzke, Scanlon, Anderson, Krueger, Flint, Lombard, Dorner, Fordham, Astle, Hazard, R. Spencer, Carver, Polivka, Burchill, Peper, Lohr, Gruber, Detter, Stehling, McAuliffe, Deitrich and McCumber. NAYS: (0). ABSENT & EXCUSED: (4) Clemens, Prosser, Schell, Chrisler. Motion carried **unanimously**.

Resolution 18-2024 To Donate The Fire Hose And Wagon From The Historic 1921 Firehouse At The Sauk County Farm To The Reedsburg Area Historical Society And Pioneer Village.

MOTION (Krueger/Hazard). VOTE: AYES: (26) Roxen, T. Spencer, Eberl, Rego, Kinsman, Klitzke, Scanlon, Anderson, Krueger, Flint, Lombard, Dorner, Fordham, Astle, Hazard, R. Spencer, Carver, Polivka, Burchill, Peper, Lohr, Gruber, Stehling, McAuliffe, Deitrich and McCumber. NAYS: (1) Detter. ABSENT & EXCUSED: (4) Clemens, Prosser, Schell, Chrisler. Motion carried.

EXECUTIVE & LEGISLATIVE COMMITTEE:

Resolution 19-2024 Authorizing The Renewal Of Sauk County's Existing Microsoft Enterprise Agreement.

MOTION (Hazard/Dorner). VOTE: AYES: (27) Roxen, T. Spencer, Eberl, Rego, Kinsman, Klitzke, Scanlon, Anderson, Krueger, Flint, Lombard, Dorner, Fordham, Astle, Hazard, R. Spencer, Carver, Polivka, Burchill, Peper, Lohr, Gruber, Detter, Stehling, McAuliffe, Deitrich and McCumber. NAYS: (0). ABSENT & EXCUSED: (4) Clemens, Prosser, Schell, Chrisler. Motion carried **unanimously**.

Resolution 20-2024 To Adopt The Public Participation Plan As Part Of The Sauk County 2024 Hazard Mitigation Plan Update.

MOTION (McAuliffe/Lohr). VOTE: AYES: (27) Roxen, T. Spencer, Eberl, Rego, Kinsman, Klitzke, Scanlon, Anderson, Krueger, Flint, Lombard, Dorner, Fordham, Astle, Hazard, R. Spencer, Carver, Polivka, Burchill, Peper, Lohr, Gruber, Detter, Stehling, McAuliffe, Deitrich and McCumber. NAYS: (0). ABSENT & EXCUSED: (4) Clemens, Prosser, Schell, Chrisler. Motion carried **unanimously**.

PERSONNEL AND EXECUTIVE & LEGISLATIVE COMMITTEES:

Resolution 21-2024 Authorizing The Acquisition Of A Learning Management System From TalentLMS.

MOTION (Gruber/Kinsman). VOTE: AYES: (27) Roxen, T. Spencer, Eberl, Rego, Kinsman, Klitzke, Scanlon, Anderson, Krueger, Flint, Lombard, Dorner, Fordham, Astle, Hazard, R. Spencer, Carver, Polivka, Burchill, Peper, Lohr, Gruber, Detter, Stehling, McAuliffe, Deitrich and McCumber. NAYS: (0). ABSENT & EXCUSED: (4) Clemens, Prosser, Schell, Chrisler. Motion carried **unanimously**.

LAND RESOURCES & ENVIRONMENT AND FINANCE COMMITTEES:

Resolution 22-2024 To Authorize The Director Of Land Resources And Environment To Accept Multi-Discharge Variance Funding; And Amending The 2024 Budget. *Requires 2/3 Vote.

MOTION (Krueger/Polivka). VOTE: AYES: (27) Roxen, T. Spencer, Eberl, Rego, Kinsman, Klitzke, Scanlon, Anderson, Krueger, Flint, Lombard, Dorner, Fordham, Astle, Hazard, R. Spencer, Carver, Polivka, Burchill, Peper, Lohr, Gruber, Detter, Stehling, McAuliffe, Deitrich and McCumber. NAYS: (0). ABSENT & EXCUSED: (4) Clemens, Prosser, Schell, Chrisler. Motion carried **unanimously**.

PROPERTY AND FINANCE COMMITTEES:

Resolution 23-2024 Authorizing To Contract With Omni Technologies For The Upgrade Of The Current Sauk County Fire Alarm Monitoring Software And To Amend The 2024 Building Services Capital Outlay Budget. *Requires 2/3 Vote.

MOTION (Detter/Gruber). VOTE: AYES: (27) Roxen, T. Spencer, Eberl, Rego, Kinsman, Klitzke, Scanlon, Anderson, Krueger, Flint, Lombard, Dorner, Fordham, Astle, Hazard, R. Spencer, Carver, Polivka, Burchill, Peper, Lohr, Gruber, Detter, Stehling, McAuliffe, Deitrich and McCumber. NAYS: (0). ABSENT & EXCUSED: (4) Clemens, Prosser, Schell, Chrisler. Motion carried **unanimously**.

FINANCE AND PERSONNEL & INSURANCE COMMITTEES:

Resolution 24-2024 Authorizing The Elected Officials (County Clerk, Register Of Deeds, and Treasurer) Salaries For The 2025-2028 Term Of Office.

MOTION (Gruber/Polivka). VOTE: AYES: (26) T. Spencer, Eberl, Rego, Kinsman, Klitzke, Scanlon, Anderson, Krueger, Flint, Lombard, Dorner, Fordham, Astle, Hazard, R. Spencer, Carver, Polivka, Burchill, Peper, Lohr, Gruber, Detter, Stehling, McAuliffe, Deitrich and McCumber. NAYS: (0). ABSENT & EXCUSED: (5) Roxen, Clemens, Prosser, Schell, Chrisler. Motion carried **unanimously**.

**Supervisor Roxen absent from room during vote.*

LAW ENFORCEMENT & JUDICIARY AND FINANCE COMMITTEES:

Resolution 25-2024 To Amend The 2024 Budget For Allocation Of American Rescue Plan Act (ARPA) Funds For Squad Special Equipment And Squad Car. *Requires 2/3 Vote.

MOTION (Scanlon/Carver). VOTE: AYES: (26) T. Spencer, Eberl, Rego, Kinsman, Klitzke, Scanlon, Anderson, Krueger, Flint, Lombard, Dorner, Fordham, Astle, Hazard, R. Spencer, Carver, Polivka, Burchill, Peper, Lohr, Gruber, Detter, Stehling, McAuliffe, Deitrich and McCumber. NAYS: (0). ABSENT & EXCUSED: (5) Roxen, Clemens, Prosser, Schell, Chrisler. Motion carried **unanimously**.

**Supervisor Roxen absent from room during vote.*

LAW ENFORCEMENT & JUDICIARY COMMITTEE:

Resolution 26-2024 To Authorize Sauk County Sheriff's Office To Enter Into A Contract Agreement With Southern Health Partners To Oversee And Provide Licensed Healthcare Services For Jail Inmates.

MOTION (Scanlon/Carver). VOTE: AYES: (26) T. Spencer, Eberl, Rego, Kinsman, Klitzke, Scanlon, Anderson, Krueger, Flint, Lombard, Dorner, Fordham, Astle, Hazard, R. Spencer, Carver, Polivka, Burchill, Peper, Lohr, Gruber, Detter, Stehling, McAuliffe, Deitrich and McCumber. NAYS: (0). ABSENT & EXCUSED: (5) Roxen, Clemens, Prosser, Schell, Chrisler. Motion carried **unanimously**.

**Supervisor Roxen absent from room during vote.*

18. Referrals.

19. New Agenda items (no discussion). Submit in writing or by e-mail new business items to the County Administrator as soon as possible for Rule III.A. referral.

20. Adjournment to a date certain: 6:56 P.M. MOTION (Kinsman/Klitzke) to adjourn until Tuesday, April 16, 2024, at 6:00 P.M. Motion carried **unanimously**.

Respectfully submitted,

Coralisa McDonnell
Deputy County Clerk

Minutes Approved: April 16, 2024.

State of Wisconsin, County of Sauk: I certify that the above is a true and correct copy of the March 19, 2024. Proceedings of the Sauk County Board of Supervisors. Original documents on file @ Office of the Sauk County Clerk West Square Building, 505 Broadway, Room #144, Baraboo, WI 53913. 608-355-3286.

www.co.sauk.wi.us

These notices may also be found at: <http://www.wisconsinpublicnotices.org/> or <https://www.co.sauk.wi.us/legalnotices>.

RESOLUTION # 13 -2024

Resolution to Commend Theresa Dietz for More Than 28 Years of Faithful Service To The People of Sauk County.

Resolution offered by the Health Care Center Board of Trustees

Resolved by the Board of Supervisors of Sauk County, Wisconsin:

BACKGROUND: It is the custom of the Sauk County Board of Supervisors to recognize individuals who have served the people of Sauk County with distinction. Theresa Dietz faithfully served the people of Sauk County as the Business Manager, and Billing Specialist . Theresa Dietz was an essential team member to the Sauk County Health Care Center and all of Sauk County for over 28 years.

THEREFORE, BE IT RESOLVED, by the Sauk County Board of Supervisors, met in regular session, that the Sauk county Board of Supervisors express its sincere appreciation and admiration for Theresa Dietz and her over 28 years of faithful service to the people of Sauk County.

AND, BE IT FURTHER RESOLVED, that the Chairman of the Sauk County Board of Supervisors is hereby directed to present Theresa Dietz an appropriate symbol of our appreciation for service to the people of Sauk County.

Approved for presentation to the County Board by the Heath Care Center Board of Trustees Committee, this 19th day of Mach 2024

Consent Agenda Item: YES NO

Fiscal Impact: None Budgeted Expenditure Not Budgeted

Vote Required: Majority = _____ 2/3 Majority = _____ 3/4 Majority = _____

The County Board has the legal authority to adopt: Yes _____ No _____ as reviewed by the Corporation Counsel, _____, Date: _____.

Offered and passage moved by:

Bryant Hazard, Supervisor

Joan Fordham, Supervisor

Rebecca Klitzke, Supervisor

Mike Flint, Supervisor

William Higgins, Citizen Member

52
53
54
55
56
57
58
59
60
61
62
63
64
65
66
67
68
69

Dana Horkan-Gant, Citizen Member

Cindy Bodendein, Citizen Member

Fiscal Note: No Fiscal impact.



MIS Note: No information systems impact.

RESOLUTION # 14 -2024

Resolution to Commend David Webber for More Than 15 Years of Faithful Service To The People of Sauk County.

Resolution offered by the Health Care Center Board of Trustees

Resolved by the Board of Supervisors of Sauk County, Wisconsin:

BACKGROUND: It is the custom of the Sauk County Board of Supervisors to recognize individuals who have served the people of Sauk County with distinction. David Webber faithfully served the people of Sauk County as a Maintenance Technician. David Webber was an essential team member to the Sauk County Health Care Center and all of Sauk County for over 15 years.

THEREFORE, BE IT RESOLVED, by the Sauk County Board of Supervisors, met in regular session, that the Sauk County Board of Supervisors express its sincere appreciation and admiration for David Webber and his over 15 years of faithful service to the people of Sauk County.

AND, BE IT FURTHER RESOLVED, that the Chairman of the Sauk County Board of Supervisors is hereby directed to present David Webber an appropriate symbol of our appreciation for service to the people of Sauk County.

Approved for presentation to the County Board by the Health Care Center Board of Trustees Committee, this 19th day of March 2024

Consent Agenda Item: YES NO

Fiscal Impact: None Budgeted Expenditure Not Budgeted

Vote Required: Majority = _____ 2/3 Majority = _____ 3/4 Majority = _____

The County Board has the legal authority to adopt: Yes _____ No _____ as reviewed by the Corporation Counsel, _____, Date: _____.

Offered and passage moved by:

Bryant Hazard, Supervisor

Joan Fordham, Supervisor

Rebecca Klitzke, Supervisor

Mike Flint, Supervisor

William Higgins, Citizen Member

52
53
54
55
56
57
58
59
60
61
62
63
64
65
66
67
68
69

Dana Horkan-Gant, Citizen Member

Cindy Bodendein, Citizen Member

Fiscal Note: No Fiscal impact.



MIS Note: No information systems impact.

RESOLUTION # 15 - 2024

Resolution Gratefully Accepting Donations and Gifts Presented to Sauk County in 2023

Resolution offered by the Finance Committee

Resolved by the Board of Supervisors of Sauk County, Wisconsin:

BACKGROUND: Sauk County annually receives significant donations from many entities, including clients, service recipients and their families, and businesses. These donations, including goods and services, benefit the overall good of the Sauk County public by enhancing educational programs, purchasing items for client use, and providing services for clients. Use of donations assists Sauk County in providing important services for various public purposes that promote the public good, while minimizing the impact to the property tax. Wis. Stat. § 59.52(19) permits the County Board to accept all donations: "the board may accept donations, gifts or grants for any public governmental purpose within the powers of the county".

NOW THEREFORE BE IT RESOLVED by the Sauk County Board of Supervisors met in regular session that Sauk County gratefully accepts the donations summarized as attached and expresses its appreciation to their donors.

Approved for presentation to the County Board by the Finance Committee, this 4th day of March, 2024

Consent Agenda Item: [] YES [X] NO

Fiscal Impact: [] None [X] Budgeted Expenditure [] Not Budgeted

Vote Required: Majority = _____ 2/3 Majority = X 3/4 Majority = _____

The County Board has the legal authority to adopt: Yes X No _____ as reviewed by the Corporation Counsel, [Signature], Date: 03.13.2024

Offered and passage moved by the Finance Committee:

_____	<input type="checkbox"/> Aye	<input type="checkbox"/> Nay	<input type="checkbox"/> Abstain	<input type="checkbox"/> Absent
Martin F. Krueger				
_____	<input checked="" type="checkbox"/> Aye	<input type="checkbox"/> Nay	<input type="checkbox"/> Abstain	<input type="checkbox"/> Absent
Thomas Dorner				
_____	<input checked="" type="checkbox"/> Aye	<input type="checkbox"/> Nay	<input type="checkbox"/> Abstain	<input type="checkbox"/> Absent
Lynn Eberl				
_____	<input type="checkbox"/> Aye	<input type="checkbox"/> Nay	<input type="checkbox"/> Abstain	<input type="checkbox"/> Absent
Richard "Mike" Flint				
_____	<input checked="" type="checkbox"/> Aye	<input type="checkbox"/> Nay	<input type="checkbox"/> Abstain	<input type="checkbox"/> Absent
Timothy McCumber				

Fiscal Note: Budgeted donations in 2023 totaled \$93,025, which offsets the property tax levy. Actual donations of cash were \$152,885.57 as well as many other non-monetary donations of goods and services.

MIS Note: No MIS impact [Signature]

RESOLUTION # 16 - 2024

RESOLUTION DESIGNATING THE WEEK OF APRIL 15TH THROUGH APRIL 19TH 2024 As
"WORKZONE SAFETY AWARENESS WEEK IN SAUK COUNTY"

Resolution offered by the Highway Committee

Resolved by the Board of Supervisors of Sauk County, Wisconsin:

BACKGROUND: In 1999 the Federal Highway Administration (FHWA) partnered with the American Association of State and Highway Officials (AASHTO) and more recently with the American Traffic Safety Services Association (ATSSA) to create the National Work Zone Safety Awareness Week campaign, held annually in April prior to the construction season for much of the nation. The Wisconsin County Highway Association is asking all seventy-two (72) counties in the state to unite and kick-off "Work Zone Safety Awareness Week" with a resolution and campaign to raise awareness for its workers and those of various highway contractors performing work for the counties. According to data from UW Madison's Traffic Operations and Safety Laboratory's Community Maps between 2019 and 2023, there were 64 fatalities recorded as a result of more than 10,000 crashes within work zones which injured more than 3,800 people. Construction and maintenance activities on our streets and highways periodically require that work zones be established. There has been an average of 2,336 work zone crashes in Wisconsin in each of the last five years. In 2023, Wisconsin suffered from 2,168 crashes in road construction and maintenance zones, resulting in over 712 injuries and 10 fatalities. Through enforcement activities and other participation, the Sauk County Sheriff's Office, Wisconsin State Patrol, and the Sauk County Highway Department will work to make "Work Zone Safety Awareness Week" a success. The Federal Highway Administration has designated April 15th through April 19th, 2024, as National Work Zone Safety Awareness Week, with this year's theme being, "Work Zones are temporary. Actions behind the wheel can last forever", which focuses on awareness to all drivers in work zones of their speed and proximity to workers.

THEREFORE BE IT RESOLVED by the Sauk County Board of Supervisors that the week of April 15th through April 19th, 2024 be designated as "Work Zone Safety Awareness Week" in Sauk County.

Approved for presentation to the County Board by the Highway Committee, this 19 day of March 2024

Consent Agenda Item: [] YES [] NO

Fiscal Impact: [X] None [] Budgeted Expenditure [] Not Budgeted

Vote Required: Majority = X 2/3 Majority = _____ 3/4 Majority = _____

The County Board has the legal authority to adopt: Yes X No _____ as reviewed by the Corporation Counsel, [Signature], Date: 03.14.2024

49
50
51
52
53
54
55
56
57
58
59
60
61
62
63
64
65
66
67
68
69

Offered and passage moved by:

_____	<input type="checkbox"/> Aye	<input type="checkbox"/> Nay	<input type="checkbox"/> Abstain	<input checked="" type="checkbox"/> Absent
Brian Peper				
_____	<input checked="" type="checkbox"/> Aye	<input type="checkbox"/> Nay	<input type="checkbox"/> Abstain	<input type="checkbox"/> Absent
Smooth Dettler				
_____	<input checked="" type="checkbox"/> Aye	<input type="checkbox"/> Nay	<input type="checkbox"/> Abstain	<input type="checkbox"/> Absent
Terry Spencer				
_____	<input checked="" type="checkbox"/> Aye	<input type="checkbox"/> Nay	<input type="checkbox"/> Abstain	<input type="checkbox"/> Absent
Richard "Mike" Flint				
_____	<input checked="" type="checkbox"/> Aye	<input type="checkbox"/> Nay	<input type="checkbox"/> Abstain	<input type="checkbox"/> Absent
Kevin Schell				

Fiscal Note: None. *Just*
MIS Note: None.

1
2
3
4
5
6
7
8
9
10
11
12
13
14
15
16
17
18
19
20
21
22
23
24
25
26
27
28
29
30
31
32
33
34
35
36
37
38
39
40
41
42
43
44
45
46
47
48
49

GENERAL CODE OF SAUK COUNTY, WISCONSIN
ORDINANCE AMENDMENT # 1-2024

Ordinance Amendment to SAUK CO. CODE CHAPTER 15 TO ADD ALL-TERRAIN VEHICLE (ATV) AND UTILITY-TERRAIN VEHICLE (UTV) CROSSINGS AND ROUTES ON COUNTY HIGHWAYS

Ordinance Amendment offered by Highway Committee

BACKGROUND: The State of Wisconsin Department of Natural Resources has determined that a County Board must approve all ATV/UTV routes individually, and Sauk County has created an Ordinance regulating the uses of All-Terrain Vehicles and Utility-Terrain Vehicles in the County. In order to promote the recreational use of All-Terrain Vehicles and Utility-Terrain Vehicles, Sauk County designated all County Highways as All-Terrain Vehicle and Utility-Terrain Vehicle routes. The Sauk County Highway Committee receives petitions to designate portions of State Highways as All-Terrain Vehicles and Utility-Terrain Vehicles routes. The petitions are reviewed by the Highway Department and notification is sent to the Municipalities that have proposed county highway routes. Sauk Co. Code §15.003 states that if the Highway Committee recommends approval of a route or crossing, an ordinance approving the decision shall be prepared for consideration by the County Board. No route or crossing is approved until action of the County Board. Any route on a State Highway will also need approval by Wisconsin DOT in order to be opened to ATV/UTV traffic.

NOW, THEREFORE, THE SAUK COUNTY BOARD OF SUPERVISORS DOES ORDAIN AS FOLLOWS:

That the All-Terrain Vehicle and Utility-Terrain Vehicle routes on State Highways identified on the Appendix to this Ordinance are hereby approved, to be effective upon passage and Approval By Wisconsin DOT

Approved for presentation to the County Board by the Highway Committee this 19th day of March , 2024.

Consent Agenda Item: [] YES [] NO





Fiscal Impact: [X] None [] Budgeted Expenditure [] Not Budgeted

Vote Required: Majority = X 2/3 Majority = _____ 3/4 Majority = _____

The County Board has the legal authority to adopt: Yes X No _____ as reviewed by the Corporation Counsel, [Signature], Date: 03.14.2024 .

50 Offered and passage moved by:

51
52
53
54
55
56
57
58
59
60
61
62
63
64
65
66
67
68
69
70
71
72
73

_____	<input type="checkbox"/> Aye	<input type="checkbox"/> Nay	<input type="checkbox"/> Abstain	<input checked="" type="checkbox"/> Absent
Brian Peper				
_____ 	<input checked="" type="checkbox"/> Aye	<input type="checkbox"/> Nay	<input type="checkbox"/> Abstain	<input type="checkbox"/> Absent
Smooth Dettler				
_____ 	<input checked="" type="checkbox"/> Aye	<input type="checkbox"/> Nay	<input type="checkbox"/> Abstain	<input type="checkbox"/> Absent
Terry Spenser				
_____ 	<input checked="" type="checkbox"/> Aye	<input type="checkbox"/> Nay	<input type="checkbox"/> Abstain	<input type="checkbox"/> Absent
Richard "Mike" Flint				
_____ 	<input checked="" type="checkbox"/> Aye	<input type="checkbox"/> Nay	<input type="checkbox"/> Abstain	<input type="checkbox"/> Absent
Kevin Schell				

Fiscal Note: None 

MIS Note: None

Appendix A

2024 ATV/UTV Routes Requested

Sauk County ATV/UTV Routes and Trails

STH 136 - 0.36 Miles



ATV/UTV Routes & Trails

- Sauk County - ATV Off-Road Trails
- Sauk County - City & Village Street ATV Routes
- Sauk County - Town Road ATV Routes
- Sauk County - County & State Highway ATV Routes
- Juneau & Richland County ATV Routes
- Sauk County - PROPOSED County Highway ATV Routes
- Sauk County - PROPOSED State Highway ATV Routes

Roadways

- | | |
|------------|---------------|
| Interstate | Muni |
| Federal | Alley |
| State | Private-Named |
| County | Private |
| Town | Ramp |

**Application for ATV/UTV Routes
County & State Highways**
Last Updated: January 29, 2024

474



FOR INFORMATIONAL PURPOSES ONLY
Sauk County does not warrant the accuracy of the data, nor does it warrant any liability for any errors or omissions. Data contained in this map is limited by the method and accuracy of its collection.

Sauk County ATV/UTV Routes and Trails

STH 136 - 0.26 Miles

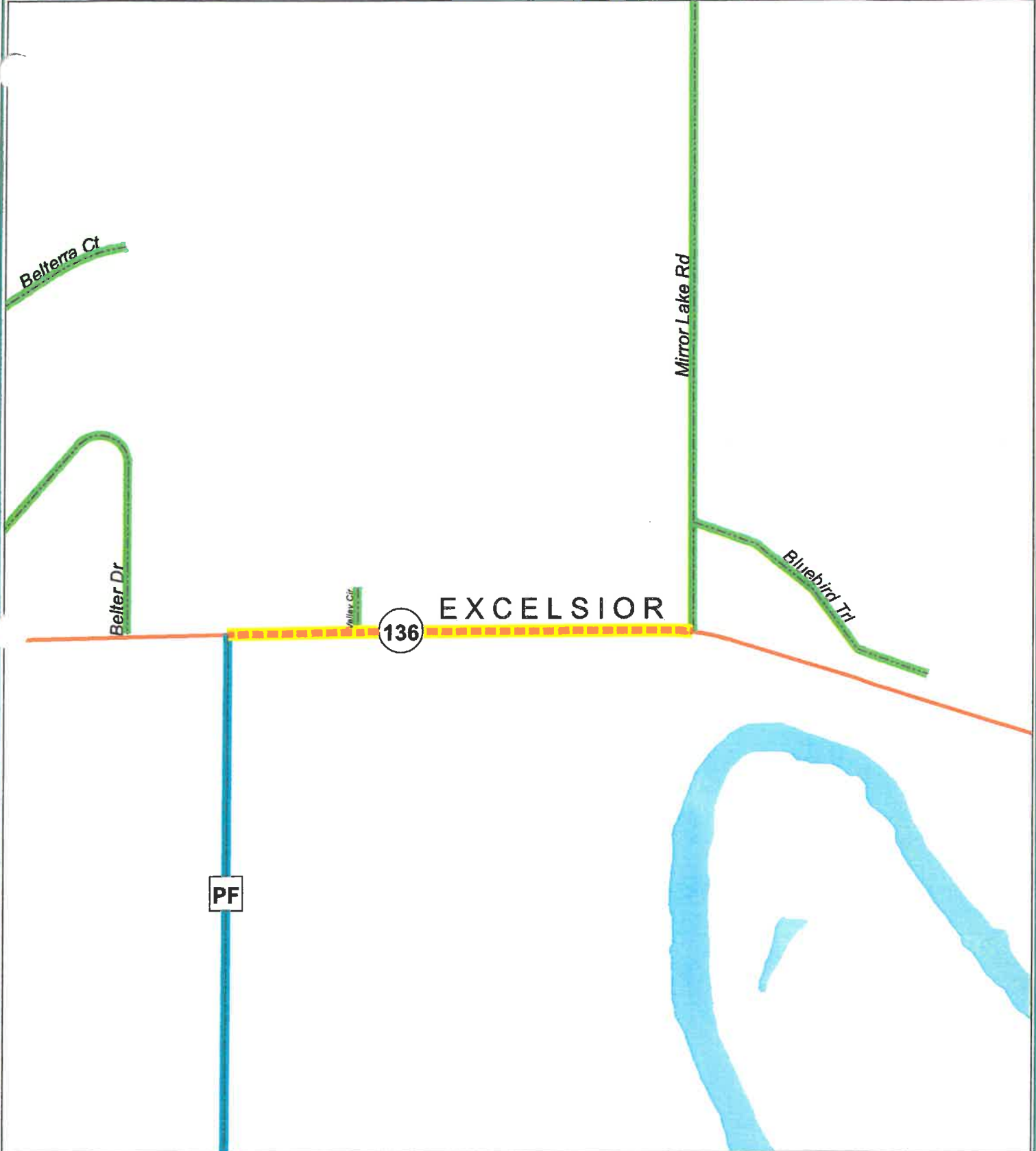

ATV/UTV Routes & Trails

- Sauk County - ATV Off-Road Trails
- Sauk County - City & Village Street ATV Routes
- Sauk County - Town Road ATV Routes
- Sauk County - County & State Highway ATV Routes
- Juneau & Richland County ATV Routes
- Sauk County - PROPOSED County Highway ATV Routes
- Sauk County - PROPOSED State Highway ATV Routes

Roadways

- Interstate
- Federal
- State
- County
- Town
- Muni
- Alley
- Private-Named
- Private
- Ramp

**Application for ATV/UTV Routes
County & State Highways**
Last Updated: January 29, 2024

475



FOR INFORMATIONAL PURPOSES ONLY
Sauk County does not warrant the accuracy
of the data presented herein and makes no
warranty with respect to its completeness or reliability.
Data sources are to the extent indicated by the number
and accuracy of the collection.

Sauk County ATV/UTV Routes and Trails

STH 113 - 0.05 Mile

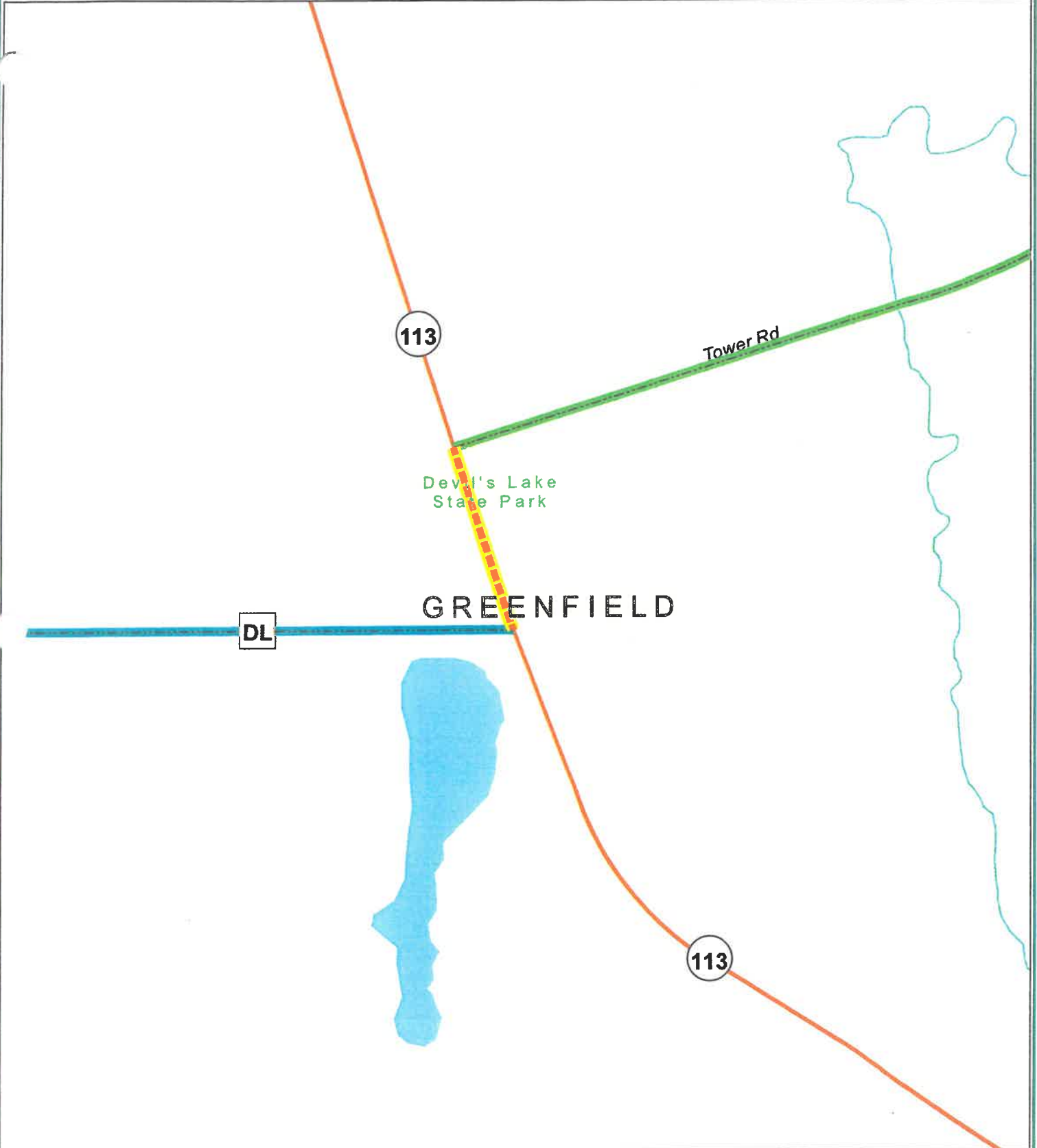

ATV/UTV Routes & Trails

- Sauk County - ATV Off-Road Trails
- Sauk County - City & Village Street ATV Routes
- Sauk County - Town Road ATV Routes
- Sauk County - County & State Highway ATV Routes
- Juneau & Richland County ATV Routes
- Sauk County - PROPOSED County Highway ATV Routes
- Sauk County - PROPOSED State Highway ATV Routes

Roadways

- | | |
|------------|---------------|
| Interstate | Muni |
| Federal | Alley |
| State | Private-Named |
| County | Private |
| Town | Ramp |

**Application for ATV/UTV Routes
County & State Highways**
Last Updated: January 29, 2024

476



FOR INFORMATIONAL PURPOSES ONLY
Sauk County does not claim the accuracy
of the data presented herein and will not
warranty with respect to its completeness or reliability.
Data compiled for this map is based on the most recent
and accurate of the collection.

Sauk County ATV/UTV Routes and Trails

STH 23 - 1.5 Miles



ATV/UTV Routes & Trails

- Sauk County - ATV Off-Road Trails
- Sauk County - City & Village Street ATV Routes
- Sauk County - Town Road ATV Routes
- Sauk County - County & State Highway ATV Routes
- Juneau & Richland County ATV Routes
- Sauk County - PROPOSED County Highway ATV Routes
- Sauk County - PROPOSED State Highway ATV Routes

Roadways

- | | |
|------------|---------------|
| Interstate | Muni |
| Federal | Alley |
| State | Private-Named |
| County | Private |
| Town | Ramp |

**Application for ATV/UTV Routes
County & State Highways**
Last Updated: January 29, 2024

477



FOR INFORMATIONAL PURPOSES ONLY
Sauk County does not claim to the accuracy
of the data contained herein and makes no
warranty with respect to its use or its reliability.
Data contained in this map is based on the best
and accuracy of its collection.

Sauk County ATV/UTV Routes and Trails

STH 60 - 0.2 Mile

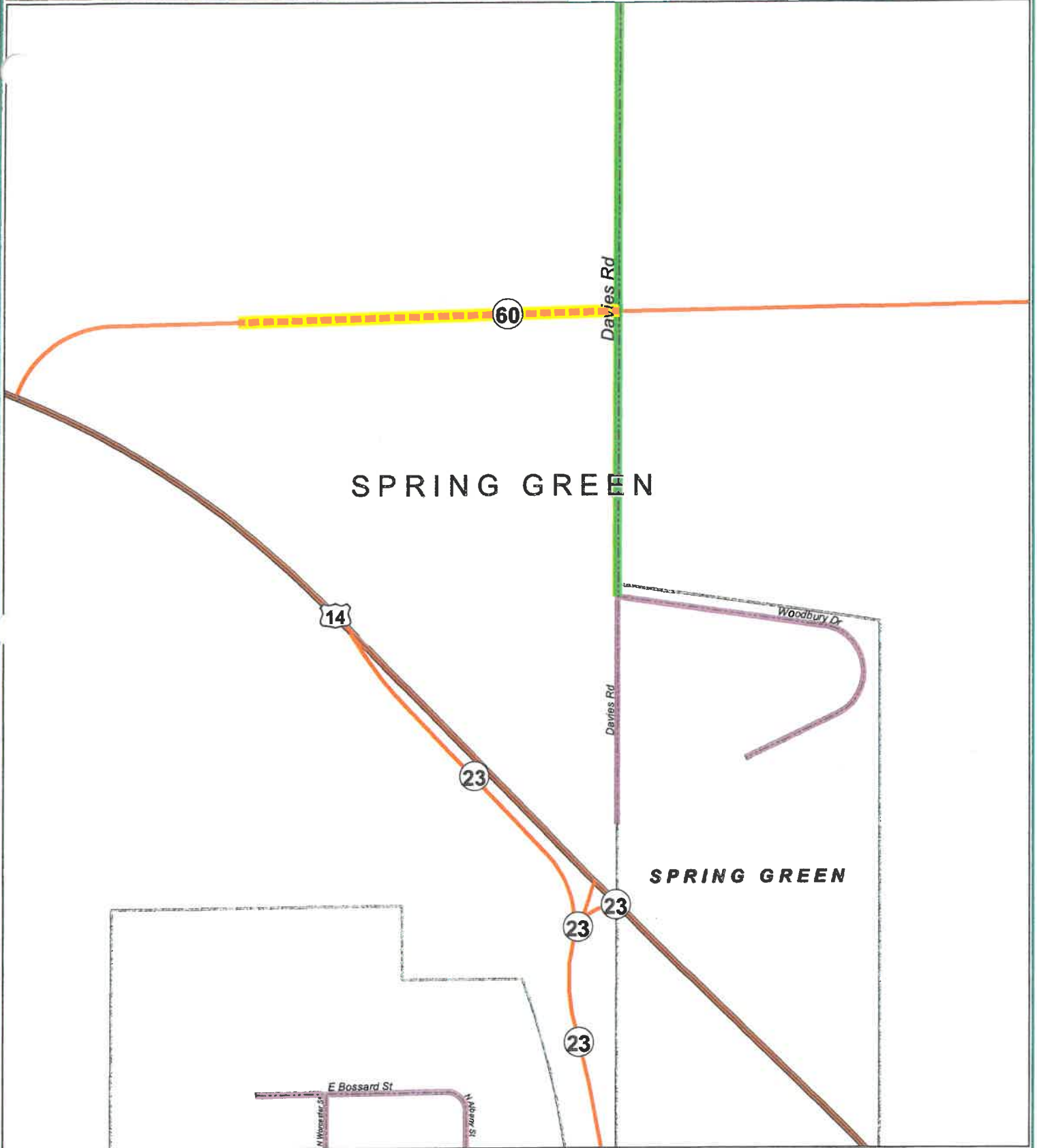

ATV/UTV Routes & Trails

- Sauk County - ATV Off-Road Trails
- Sauk County - City & Village Street ATV Routes
- Sauk County - Town Road ATV Routes
- Sauk County - County & State Highway ATV Routes
- Juneau & Richland County ATV Routes
- Sauk County - PROPOSED County Highway ATV Routes
- Sauk County - PROPOSED State Highway ATV Routes

Roadways

- | | |
|------------|---------------|
| Interstate | Muni |
| Federal | Alley |
| State | Private-Named |
| County | Private |
| Town | Ramp |

**Application for ATV/UTV Routes
County & State Highways**
Last Updated: January 29, 2024

478



N

FOR INFORMATIONAL PURPOSES ONLY
Sauk County does not claim to the accuracy
of the data presented herein and shall not
warranty any responsibility in its use or reliance.
Data contributed to this map is limited by the
accuracy of the collection.

RESOLUTION # 17 - 2024

Resolution to Authorize Participation in the State of Wisconsin Motorized Recreation Grant Programs for Snowmobile Trails, ATV/UTV Trails and Off-Highway Motorcycle Events

Resolution offered by the Land Resources and Environment Committee

Resolved by the Board of Supervisors of Sauk County, Wisconsin:

BACKGROUND: Sauk County annually participates in maintaining, acquiring, insuring and developing lands for public motorized trail and event use and these public motorized trails and events are eligible for grant funds through the Wisconsin Department of Natural Resources (DNR). 100% of these funds are applied to the costs for the acquisition, development, insurance and maintenance of public trails and events. Funding for the programs comes from registration fees, a portion of tax on gasoline and user fees. Grant applications must be submitted by the local governing body to the DNR.

The development, maintenance, grooming and event planning of the snowmobile, all-terrain vehicles/utility task vehicles (ATV/UTV) and off-highway motorcycle (OHM) trails is managed through contracts with the Association of Sauk County Snowmobile Clubs, Sauk Ridge Runners, Inc. and Driftless Dual Sport Riders, attached as Appendix A, Appendix B and Appendix C, respectively.

There are currently 238.3 miles of funded snowmobile trail in Sauk County, funded at \$300 per mile, with the grant program totaling \$71,490. Currently, there are approximately 0.59 miles of ATV/UTV trail in Sauk County, funded at \$800 per mile for summer use and \$300 per mile for winter use, with the grant program totaling \$649. There are no designated OHM trails in Sauk County, however, the OHM club annually hosts a riding event at an estimated cost of \$1,925.

The Sauk County Land Resources and Environment Department (LRE) is primarily responsible for the financial administration of the grant programs. Other responsibilities include trail inspections, maintaining and updated contract with each club or association, applying for grant funding and verifying that all written and verbal permission from all landowners is obtained. Sauk County's existing liability insurance policy protects Sauk County's interest in providing snowmobile, ATV/UTV and OHM trails and events.

THEREFORE, BE IT RESOLVED, by the Sauk County Board of Supervisors, met in regular session, that the Sauk County Parks Administrative Services Coordinator and the Sauk County Land Resources and Environment Director, under the discretion of the Sauk County Land Resources and Environment Committee, be authorized to submit applications on behalf of the above mentioned clubs to the Wisconsin Department of Natural Resources for any financial aid that may be available, submit reimbursement claims along with supporting documentation within proper timeframe of project completion dates, sign and submit documents and take necessary action to undertake, direct and complete the approved projects.

BE IT FURTHER RESOLVED, by the Sauk Board of Supervisors, that the County Administrator be authorized to execute a Development, Maintenance and Grooming Contract with the Association of Sauk County Snowmobile Clubs (Appendix A), a Development and

Maintenance Contract with the Sauk Ridge Runners, Inc. (Appendix B) and a Development, Maintenance and Event Contract with the Driftless Dual Sport Riders (Appendix C).

Approved for presentation to the County Board by the Land Resources and Environment Committee, this 19th, day of March 2024.

Consent Agenda Item: [] YES [] NO

Fiscal Impact: [] None [X] Budgeted Expenditure [] Not Budgeted

Vote Required: Majority = X 2/3 Majority = _____ 3/4 Majority = _____

The County Board has the legal authority to adopt: Yes X No _____ as reviewed by the Corporation Counsel, [Signature], Date: 03.14.2024.

Offered and passage moved by:

LAND RESOURCES AND ENVIRONMENT COMMITTEE

[Signature] Aye Nay Abstain Absent
Marty Krueger, Chair

 Aye Nay Abstain Absent
Peter Kinsman, Vice Chair

[Signature] Aye Nay Abstain Absent
Brandon Lohr, Secretary

[Signature] Aye Nay Abstain Absent
Lynn Eberl

[Signature] Aye Nay Abstain Absent
Valerie McAuliffe

[Signature] Aye Nay Abstain Absent
Dennis Polivka

 Aye Nay Abstain Absent
Randy Puttkamer

[Signature] Aye Nay Abstain Absent
Robert Spencer

Fiscal Note: Funding for the grant programs comes from snowmobile, ATV/UTV and OHM registration fees, a percentage of tax on gasoline and user fees. No County tax levy is used to fund the programs. The snowmobile grant program totals \$71,490, the ATV/UTV grant program totals \$649 and the OHM grant program totals \$1,925. [Signature]

MIS Note: None



SAUK COUNTY SNOWMOBILE TRAIL DEVELOPMENT, MAINTENANCE AND GROOMING CONTRACT

This Contract made this 19th day of March 2024, by and between the County of Sauk, a political subdivision of the State of Wisconsin, hereinafter referred to as "County", and the Association of Sauk County Snowmobile Clubs, Inc., a private snowmobile club corporation, hereinafter referred to as "Contractor".

WITNESSETH:

WHEREAS, the County wishes to ensure that snowmobile trails within Sauk County are developed and maintained in a suitable fashion to ensure that the trails are safe and enjoyable for use by the public; and,

WHEREAS, the County considers it necessary for the safety, comfort and enjoyment of the public that the snowmobile trails be groomed;

NOW THEREFORE, in consideration of the mutual covenants and agreements contained herein, the parties hereby agree as follows:

1. **Communications:** The Contractor shall designate one elected official from the Association of Sauk County Snowmobile Clubs, as set forth below, to be the point of contact for the County related to this contract. The designated elected association member shall be the only person to contact the County related to this contract and shall be the sole association member that the County is required to communicate with regarding this contract. This contract provision is intended to regulate all routine communications between the Contractor and the County. The Contractor may change their designated representative with a written amendment to this contract. All legal notices to the County shall be sent to the Sauk County Clerk.

Designated Elected Official from Association of Sauk County Snowmobile Clubs
Contact Information:

Name: _____

Email address: _____

Phone number: _____

2. **Scope of Land Area Covered by Contract:** This contract shall apply to the snowmobile trails described and known as the Sauk County Snowmobile Trail System, hereinafter referred to as "Trails", estimated at approximately 238.3 miles of state-approved snowmobile trails within the County, as specifically set forth in "Exhibit A", attached hereto and made a part hereof.
3. **Term of Contract:** This Contract shall commence on the date noted above and shall be for the 2024-2025 winter snowmobile season, unless sooner terminated pursuant to paragraph twenty-one (21) below.



4. Outdoor Motorized Recreation Trail Aids Application and Grant Award: County shall apply for outdoor motorized recreation trail aids by completion of the Outdoor Motorized Recreation Grant Application of the Wisconsin Department of Natural Resources, hereinafter referred to as "WDNR". Contractor shall submit written requests for funding by March 1 to the County. Requests received after March 1 will not be considered for the snowmobile season pursuant to paragraph three (3) above.

Completion of the appropriate WDNR Form is required under Wisconsin Statutes 23.09(26) and 23.33 and failure to do so will result in denial of financial assistance.

The County shall annually request, by resolution, the authorization of the Sauk County Board of Supervisors to participate in the State of Wisconsin Motorized Recreation Grant Program.

In the event that funding is awarded to the County, the County shall review the grant agreement with the WDNR. If the grant agreement is desirable to the County, the County shall return a copy of the signed agreement to the WDNR.

County shall apply for supplemental funding if desired by Contractor, and on the basis that funding is available through the WDNR.

5. Payment: Contractor shall submit work reports and receipts paid by the Contractor onto SNARS (Snowmobile Automated Reported System, provided by the WDNR). The County shall approve entries on SNARS monthly during the time period pursuant to paragraph twelve (12) below.

Payment to the Contractor by the County will be based upon monthly invoices, submitted by the fourth Wednesday of each month, with an itemized of invoices paid by the Contractor (the receipts) and one lump sum for work reports, and be based upon time expended. The invoice shall also include copies of each paid invoice (receipt) and the work reports and shall be sent electronically to the County.

Payment shall be made at rates in accordance with the Equipment and Labor Rate provisions adopted by the Snowmobile Recreation Advisory Council for the current snowmobile season, as specifically set forth in "Exhibit B", attached hereto and made a part hereof.

All representatives of County providing labor and/or supplies to the snowmobile program shall prepare work and expense reports. These reports shall be submitted to SNARS on an annual basis.

Contractor shall meet all of the agreements contained herein. County shall withhold payment if Contractor fails to meet the specifications listed in this contract. Once Contractor meets all specifications of the agreements contained herein, County shall submit payment within forty-five (45) days.

County shall request reimbursement for the grant by completion of the Grant Payment Request & Worksheet of the WDNR.



6. **Equipment, Tools and Labor:** Contractor agrees to furnish all tools, equipment, and labor necessary to maintain, groom, and perform all work as specified under the terms of this contract.
7. **Material:** Contractor shall furnish all signs, posts, gates and related material necessary for the development and maintenance of the trail system.
8. **Signs:** Contractor agrees to erect, replace and maintain all signs consistent with standards specified in the applicable Wisconsin Statutes, the Wisconsin Administrative Code and regulations promulgated by the WDNR.
9. **Fall Maintenance and Land Use Agreements:** Contractor agrees to perform all brushing, dragging, litter removal, and clean-up necessary to prepare the Trail to meet the specifications established by the WDNR in order to qualify the Trail for winter use. The Contractor shall provide the County with a Trail System Land Use Certification Form ("Exhibit C"), certifying that all landowners have been contacted verbally, electronically or with a signed contract and have granted permission to use his/her land and/or all necessary private property easements, leases, permits or other appropriate agreements have been secured for snowmobile trail use. County shall maintain copies of all land use agreements, update a listing of all landowners annually, and verify that all land use agreements are secured. County shall notify Contractor of any absent land use agreements, and Contractor shall provide absent land use agreements within one (1) month of notice. County shall annually send land use certification(s) to the WDNR.
10. **Spring Clean-up and Removal of Signs:** At the end of the snowmobile season, and no later than April 15, Contractor shall remove signs as appropriate, clean-up and remove all litter from the subject Trail. The Contractor shall provide the County with a Trail System Closure Certification Form ("Exhibit D") certifying fence closures have been completed, gates have been inspected and/or closed, the appropriate signs and/or markers have been removed, and that the trail section has been cleaned-up and closed in accordance with trail specifications established by the WDNR after the Trail system has been closed for each year. County shall annually send closure certification(s) to the WDNR.
11. **Grooming:** The Contractor shall groom the trails to the trail specifications established by the WDNR.
12. **Trail Opening and Closing:** The Trail system shall be considered open during the time period from December 1 to March 31 of each year. All signs, gates, markers and related items shall be in place and the trail is in a safe operating condition as of December 1. The Contractor shall provide the County with a Trail System Opening Certification Form ("Exhibit E") certifying that all fence openings have been completed, gates have been inspected and/or opened, the required signs and/or markers have been installed and the trail section has been developed to acceptable safety standards and in accordance with trail specifications established by the WDNR, before the Trail system is opened to the public. County shall annually send opening certification(s) to the WDNR.

The Contractor will determine if conditions are, or are not, suitable for snowmobiling and will open and close the trails accordingly. Contractor shall notify County of trail opening and trail closing at least one (1) hour prior to trail opening and trail closing. The County will maintain a



record of trail openings and closures. The Contractor shall suspend all grooming operations during closure except as otherwise specifically authorized by County.

13. **Safety Procedures - Equipment:** Contractor shall attach a blinking light on top of the vehicle used during grooming and shall have headlights, taillights, and blinking lights on and working at all times. All grooming equipment and vehicles shall be clearly marked with "Slow Moving Vehicle" signs to safeguard other Trail users.

County shall inspect trails randomly during the time period from December 1 to March 31 of each year. County shall inform Contractor of any adverse determination regarding the trails and allow Contractor an opportunity to be heard in that regard and require Contractor to develop the trails to the acceptable safety standards and in accordance with the trail specifications established by the WDNR immediately after notice.

14. **Independent Contractor Status:** The Contractor is an independent contractor and not an agent or employee of the County. Contractor shall placard or otherwise mark its equipment with the Contractor's name on both sides of its equipment.

15. **Indemnification:** Contractor agrees to save, hold harmless, defend and indemnify the County and the State of Wisconsin and all its officers, employees and agents, against any and all liability claims, costs of whatever kind and nature, for injury to or death of any person or persons, and for loss or damage to any property, County, State or other, occurring in connection with or in any way incident to or arising out of the occupancy, use, service, operation or performance of the work in connection with this Contract.

16. **Insurance Coverage:** The Contractor shall carry liability coverage for its officers, employees, and agents in the amount of \$500,000.00 for each single personal injury, \$500,000.00 for each multiple personal injury, and \$500,000.00 for each property damage. The Contractor shall also carry liability coverage in the amount of \$2,000,000.00 to indemnify the applicable rail authority for damages from the design, construction, maintenance, existence or use of an established rail crossing or a snowmobile rail crossing for which a permit has been issued by the WDNR. The Contractor shall provide the County with acceptable certificates of insurance, from a corporation licensed in the State of Wisconsin to provide insurance, before the Trail system is opened to the public and before January 31 of each year. County shall annually send insurance certification(s) to the WDNR and other appropriate entities.

17. **Conduct:** The Contractor agrees that its agents, employees and representatives shall conduct themselves in a decent, orderly, and business-like manner at all times while performing under this Contract.

18. **Compliance:** Contractor agrees to follow and comply with the applicable Wisconsin Statutes, Wisconsin Administrative Code, the regulations promulgated by the State of Wisconsin Department of Natural Resources, and of Sauk County Code of Ordinances.

19. **Amendment of Contract:** This contract may only be amended, changed, or modified in writing by mutual agreement of the parties.



20. Assignment: Contractor shall not assign, subcontract, or otherwise transfer this Contract except with the express written approval of the County.
21. Contract Termination: Notwithstanding any provision herein, the County reserves the right to terminate this Contract, for cause, upon seven (7) days written notice to the Contractor if the County determines that the Contractor's operation is unsatisfactory in any respect or if the County determines that the Contractor has failed, neglected, or refused to comply with the terms of this Contract. This contract is also subject to the availability of funding and shall be terminated in the event that funding for the required services is not available. In such event, the County shall notify the Contractor of such termination due to funding constraints.
22. Form of Contract: Section 16.76(1) of the Wisconsin Statutes, is incorporated by reference into this contract, as applicable.
23. Applicable Law: This Contract shall be construed and governed by the rules and laws of the State of Wisconsin.

IN WITNESS WHEREOF, the parties hereto have executed this Contract on the date set forth herein.

COUNTY OF SAUK

Administrator, Sauk County

Date

ASSOCIATION OF SAUK COUNTY SNOWMOBILE CLUBS, INC.

President

Date

Secretary

Date

Sauk County Snowmobile Trails

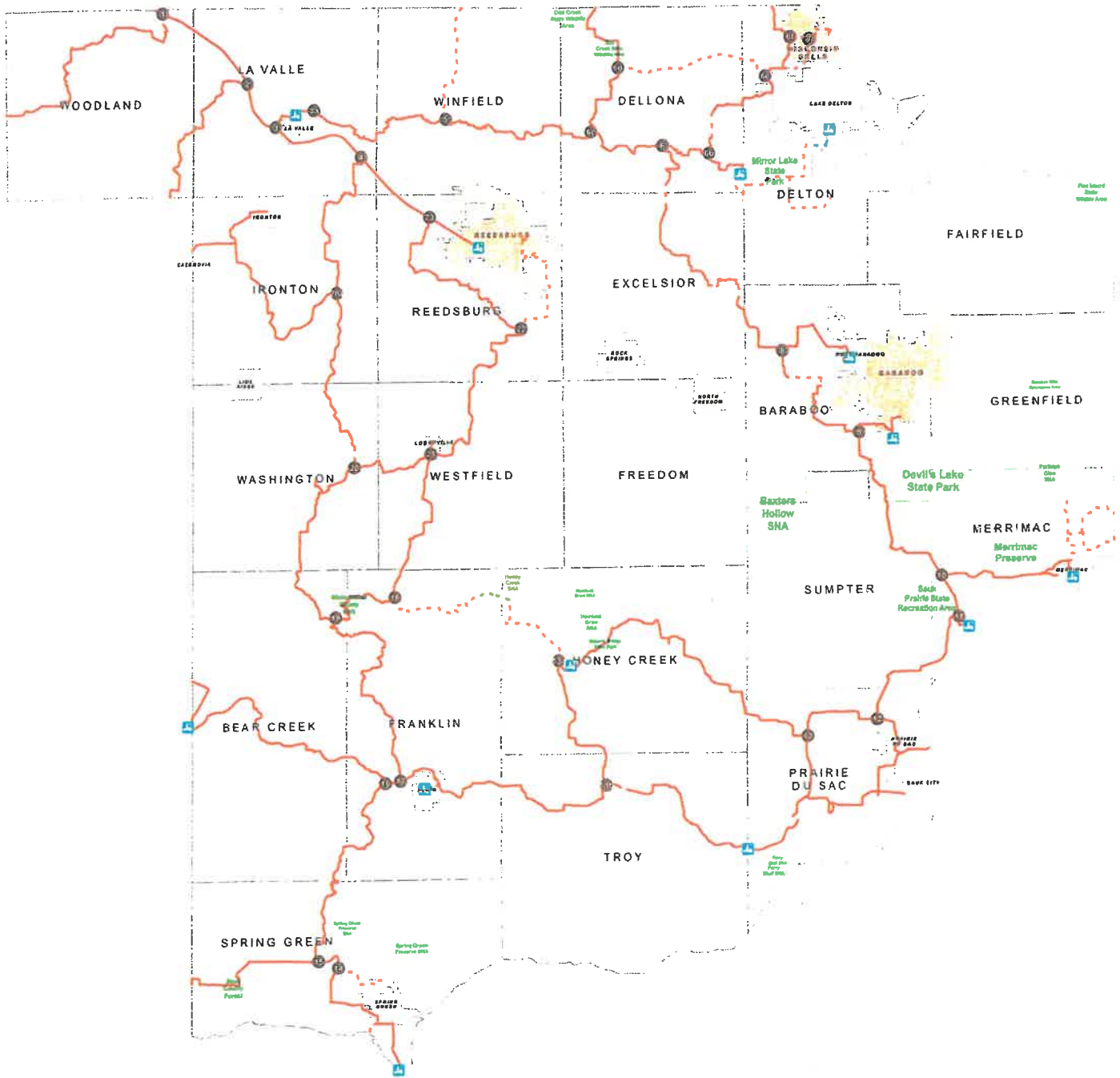

Sauk County Land Information\GIS Department

Snowmobile POI	Facility Sites-Parks	College / University	Public Access	Ski Area / Ski Resort
<ul style="list-style-type: none"> Loading & Unloading Area Snowmobile Intersection Trails 	Feature Code <ul style="list-style-type: none"> Agriculture Experimental Station Airport Runway / Airfield Amusement / Water Park Cemeter Trails 	<ul style="list-style-type: none"> Fair / Exhibition / Race Grounds Golf Course Government or Military Facility Hospital / Medical Center Lease / Rent 	<ul style="list-style-type: none"> Rest Stop / Roadside Park School School: Elementary School: High School School: Middle School 	<ul style="list-style-type: none"> Sports Arena / Stadium Beer Supply or Treatment Facility Municipal Boundaries City Town Village



486
GIS INFORMATION IS UNOFFICIAL ONLY
 Sauk County may not be responsible for any errors or omissions in this information.

Equipment and Labor Rates for 2023-24 Season
Adopted by Snowmobile Recreation Council & Off-Road Vehicle Council

I. SNOW TRAIL GROOMING EQUIPMENT RATES - All rates include power unit, grooming drag & operator(s).

Class	Description	Rate/Hour
AAA	All heavy duty tracked units constructed specifically for snow grooming with a minimum of 150 horsepower and capable of pulling on a sustained basis a hydraulically operated grooming drag of at least 7'6" (90 inches) frame width. OR All fully tracked agricultural tractors with a minimum of 125 horsepower. OR Trucks: minimum 1-ton (4-wheel drive), minimum payload of 3,500 lbs., fully-tracked with a minimum manufactured 15,000 GWV track system.	\$5 more than AA AAA1 - \$100 AAA2 - \$90 AAA3 - \$80 AAA4 - \$70
AA	All heavy duty tracked units constructed specifically for snow grooming having between 149 - 106 horsepower and capable of pulling on a sustained basis a hydraulically operated grooming drag of at least 7'6" (90 inches) frame width. OR All fully tracked agricultural tractors with 106 – 124 horsepower.	\$5 more than A AA1 - \$95 AA2 - \$85 AA3 - \$75 AA4 - \$65
A	All wheeled or half-track agricultural tractors with all-wheel drive, minimum of 105 horsepower and capable of pulling on a sustained basis a hydraulically operated grooming drag of at least 7'6" (90 inches) frame width.	A1 - \$90 A2 - \$80 A3 - \$70 A4 - \$60
1	Drag is a minimum of 11'6" (138 inches) frame width with a minimum weight of 4,000 pounds and a length of at least 20 feet including snow packing pan but excluding the tongue.	Wings that fold down outside the main frame do not increase the drag width for funding purposes. Class is based on static frame dimensions.
2	Drag is a minimum of 9'6" (114 inches) frame width with a minimum weight of 3,000 pounds and a length of at least 18 feet including snow packing pan but excluding the tongue.	
3	Drag is a minimum of 7'6" (90 inches) frame width with a minimum weight of 2,000 pounds and a length of at least 18 feet including snow packing pan but excluding the tongue.	
4	Drag is a minimum of 7'6" (90 inches) frame width.	
B	All medium duty (including pick-up trucks) tracked units constructed or adapted specially for snow grooming and capable of pulling on a sustained basis a grooming drag 5'10" to 7'5" (70-89 inches) frame width. OR All wheel type agricultural tractors with all-wheel drive or four- wheel drive assist with a range of 65-104 horsepower.	\$50.00
C	All light duty power units constructed or adapted for snowmobile trail grooming and capable of pulling on a sustained basis a grooming drag 4' to 5'9" (48-69 inches) frame width. Examples of the class of power units would include: ATVs/UTVs and snowmobiles. This class also includes all equipment not addressed in other classes.	\$35.00

Notes regarding correct rates for grooming equipment:

1. A Class A power unit pulling either an 11'6" or 9'6" grooming drag that does **not** meet the specifications for either 1, 2 or 3 drags will be placed at level 4 for rate purposes.
2. A Class A power unit **not** pulling a 7'6" grooming drag will be placed in Class B for rate purposes.
3. A Class B power unit **not** pulling a 5'10" grooming drag will be placed in Class C for rate purposes.
4. A power unit will **not** be placed in a higher class if it pulls a larger grooming drag than specified for the class.
5. Modifications to the drag must maintain original cutting and packing function as designed. Modifications made outside the main frame will not increase the funding class.
6. Those winged drags that were previously funded and met the specifications as stated prior 2022-23 season may continue to be funded at their previous classification (drag dimensions included) for a period of 10 years (through 2031-32)
7. Groomer time spent traveling on a route that is an integral part of a single funded trail may be funded at a rate of 50% of the assigned groomer rate, as non-grooming transport time. DNR will determine if route is integral to the funded trail.

Equipment and Labor Rates for 2023-24 Season
Adopted by Snowmobile Recreation Council & Off-Road Vehicle Council

II NON-GROOMING MAINTENANCE LABOR AND EQUIPMENT RATES A

MAINTENANCE LABOR (For other than trail grooming)

A labor rate of **\$9.00** per hour maximum is established for all non-grooming labor performed in **WINTER** trails, or **\$12.00** per hour maximum on any **SUMMER ATV/UTV trails** under the maintenance agreement by snowmobile clubs and or other similar organizations with the sponsoring county. Maintenance will generally include mowing and brushing, sign and post replacement, plowing of parking lots and roads, shelter and toilet maintenance and normal repair and replacement of structures and facilities.

The allowable labor rate for county employees and others included in labor contracts will be as specified by contract.

B EQUIPMENT RATES (For other than trail grooming)

The following schedule is based on frequently used pieces of equipment for non-grooming maintenance. The Department of Transportation rates are considered when these rates are reviewed each year.

Equipment rates for pieces of equipment not found on this list will be found in the DOT rates. Unless specified otherwise, these rates for equipment are based on hourly use. These rates do **not** include the operator. Where the Department of Transportation issues rates that reflect an adjustment due to fuel rates, these rates shall be the rates utilized for the season.

Class	Description	Rate
101	All trucks pickups	\$16.00
105	All trucks single axle dual-tire over 26,000 lbs.	\$56.00
128	All Trucks, tandem, tri, quad axle	\$60.00
203	All Tired tractors & All skid-steers up to 49 hp	\$28.00
205	All Tired tractors & All skid-steers 50-99 hp	\$33.00
206	All Tired tractors & All skid-steers 100-149 hp	\$43.00
207	All Tired tractors & All skid-steers 150 hp and up	\$52.00
215	All Fully Tracked tractors & dozers up to 99 hp	\$48.00
217	All Fully Tracked tractors & dozers 100 - 149 hp	\$53.00
218	All Fully Tracked tractors & dozers 150 hp and up	\$82.00
401	Air compressor all types	\$14.00
410	Motorized mower over 23" (self-contained or pull behind)	\$15.00
413	Mower—tractor mounted	\$16.00
414	Sickle attached to power unit	\$16.00
490	Trailer less than 1 ton (use mfr. rated capacity)	\$11.00
491	Trailer 1-4 tons (use mfr. rated capacity)	\$15.00
493	All Trailers over 4 ton	\$26.00
550	Rubber tired Backhoe (80 HP and over) was # 250	\$55.00
555	Excavator Track type (less than 100 HP)	\$48.00
558	Excavator Track type (100 - 149HP)	\$52.00
559	Excavator Track type (150HP and over)	\$65.00
802	Portable electric generator (all types)	\$18.00
902	Chipper self-contained (minimum 25 hp)	\$33.00
914	Chain Saw, pole saw, power pruner, brush saw, weed eaters	\$6.50
914T	Trailblazer brush cutter (attachment)	\$10.50
915	Auger (attachment for tractor/ skid steer), Post pounder-hydraulic	\$32.00

Equipment and Labor Rates for 2023-24 Season
Adopted by Snowmobile Recreation Council & Off-Road Vehicle Council

916	Hand-held motorized post-hole digger	\$13.00
919	Disc/spring tooth harrow/cultimulcher/cultipacker/rototiller	\$11.00
922	Welder	\$4.00
932	Brush Cutter - hydraulic driven/Fecon head	\$30.00
940	Brush Cutter—PTO driven	\$23.00
953	Boom for brush cutter	\$15.50
9042	Gas drill	\$5.00
9145	Snowmobile/ATV/UTV	\$19.00
9152	Stump grinder (all) hydraulic/self powered	\$36.00
9205	Rear blade/box scraper/pull behind grader/packing pan/rollers	\$8.00
9406	Chipper, PTO driven	\$25.00

ATV Summer Supplement
Adopted by the Off Road Vehicle Advisory Council

Spring/Summer/Fall Trail Grooming Drags

Class	Description	Rate Per Hour
Class 1	Drag is a minimum of 7'6" in frame width with a minimum length of at least 16' excluding the tongue. Drag contains at least 2 sets of replaceable cutting blades	\$11.00
Class 2	Drag is a minimum of 7'6" in frame width	\$9.00

Example of Class 1 Drag



Sauk County Land Resources and Environment Department
 Attn: Parks and Recreation
 S7995 White Mound Drive
 Hillpoint, WI 53937
 (608) 355-4800

Trail System Land Use Certification

Form: LUC2018
 Revised: 02/15/2024

Notice: Completion of this form is required under the Development, Maintenance and Grooming Contract between the Sauk County Land Resources and Environment Department and the Association of Sauk County Snowmobile Clubs, Inc. Due date is December 1 of each snowmobile season.

Instructions: Complete this form after all landowners in your club section have been contacted and have granted permission to use his/her land and/or all necessary private property easements, leases, permits or other appropriate agreements have been secured for snowmobile trail use. Send completed form to the Sauk County Land Resources and Environment Department, Attn: Parks and Recreation, S7995 White Mound Drive, Hillpoint, WI 53937.

Section 1: Information

Year of Snowmobile Season	Snowmobile Club
---------------------------	-----------------

Printed Name of Individual Authorized to Act on Behalf of Club

Mailing Address for Club

City	State	Zip Code
------	-------	----------

Telephone Number of Authorized Individual

Email Address of Authorized Individual

Section 2: Trail IDs

List all County-funded trails for the snowmobile club listed above

BARABOO	B1, B2, B3, B4, B5
HILLCREST	HC1N, HC2N, HC5N, HC6N, HC7N, HC1E, HC3E, HC1S, HC2S, HC3S, HC1W, HC2W, HC3W
HILLSBORO	HTB34
HONEY CREEK	H1, H2, H3, H4, H5
MERRIMAC	M1, M2, M3, M4, M5, M6, M7
REDSTONE	RR1, RR2, RRCORR23
REDSBURG	R1, R2
ROCK SPRINGS	RS1, RS2, RS3
WHITE MOUND	WM1, WM2, WM3, WM4, WM5, WM6, WM7
WINFIELD	W1, W2, W3, W5, W6

Section 3: Certification

As the individual authorized of the snowmobile club listed above in "Section 1: Information; Snowmobile Club", of the Sauk County Snowmobile Trail System, described as the portion listed above in "Section 2: Trail IDs", by my signature, I hereby certify that all landowners in my club section have been contacted verbally, electronically or with a signed contract and have granted permission to use his/her land and/or all necessary private property easements, leases, permits or other appropriate agreements have been secured for snowmobile trail use for the upcoming snowmobile season.

Signature of Authorized Individual

490

Date Prepared

Sauk County Land Resources and Environment Department
 Attn: Parks and Recreation
 S7995 White Mound Drive
 Hillpoint, WI 53937
 (608) 355-4800

Trail System Closure Certification

Form: CC2018
 Revised: 02/15/2024

Notice: Completion of this form is required under the Development, Maintenance and Grooming Contract between the Sauk County Land Resources and Environment Department and the Association of Sauk County Snowmobile Clubs, Inc. Due date is April 15 of each snowmobile season.

Instructions: Complete this form after all fence closures have been completed, gates have been inspected and/or closed, the appropriate signs and/or markers have been removed and the trail section has been cleaned-up and closed. Send completed form to the Sauk County Land Resources and Environment Department, Attn: Parks and Recreation, S7995 White Mound Drive, Hillpoint, WI 53937.

Section 1: Information

Year of Snowmobile Season	Snowmobile Club
---------------------------	-----------------

Printed Name of Individual Authorized to Act on Behalf of Club

Mailing Address for Club

City	State	Zip Code
------	-------	----------

Telephone Number of Authorized Individual

Email Address of Authorized Individual

Section 2: Trail IDs

List all County-funded trails for the snowmobile club listed above

BARABOO	B1, B2, B3, B4, B5
HILLCREST	HC1N, HC2N, HC5N, HC6N, HC7N, HC1E, HC3E, HC1S, HC2S, HC3S, HC1W, HC2W, HC3W
HILLSBORO	HTB34
HONEY CREEK	H1, H2, H3, H4, H5
MERRIMAC	M1, M2, M3, M4, M5, M6, M7
REDSTONE	RR1, RR2, RRCORR23
REEDSBURG	R1, R2
ROCK SPRINGS	RS1, RS2, RS3
WHITE MOUND	WM1, WM2, WM3, WM4, WM5, WM6, WM7
WINFIELD	W1, W2, W3, W5, W6

Section 3: Certification

As the individual authorized of the snowmobile club listed above in "Section 1: Information; Snowmobile Club", of the Sauk County Snowmobile Trail System, described as the portion listed above in "Section 2: Trail IDs", by my signature, I hereby certify that all fence closures have been completed, gates have been inspected and/or closed, the appropriate signs and/or markers have been removed and the trail section has been cleaned-up and closed in accordance with trail specifications of the Sauk County Land Resources and Environment Department, Parks and Recreation Services.

Signature of Authorized Individual

491

Date Prepared

Sauk County Land Resources and Environment Department
 Attn: Parks and Recreation
 S7995 White Mound Drive
 Hillpoint, WI 53937
 (608) 355-4800

Trail System Opening Certification

Form: OC2018
 Revised: 02/15/2024

Notice: Completion of this form is required under the Development, Maintenance and Grooming Contract between the Sauk County Land Resources and Environment Department and the Association of Sauk County Snowmobile Clubs, Inc. Due date is December 1 of each snowmobile season.

Instructions: Complete this form after all fence openings have been completed, gates have been inspected and/or opened, the required signs and/or markers have been installed, and the trail is in a safe operating condition. Send completed form to the Sauk County Land Resources and Environment Department, Attn: Parks and Recreation, S7995 White Mound Drive, Hillpoint, WI 53937.

Section 1: Information

Year of Snowmobile Season	Snowmobile Club
---------------------------	-----------------

Printed Name of Individual Authorized to Act on Behalf of Club

Mailing Address for Club

City	State	Zip Code
------	-------	----------

Telephone Number of Authorized Individual

Email Address of Authorized Individual

Section 2: Trail IDs

List all County-funded trails for the snowmobile club listed above

BARABOO	B1, B2, B3, B4, B5
HILLCREST	HC1N, HC2N, HC5N, HC6N, HC7N, HC1E, HC3E, HC1S, HC2S, HC3S, HC1W, HC2W, HC3W
HILLSBORO	HTB34
HONEY CREEK	H1, H2, H3, H4, H5
MERRIMAC	M1, M2, M3, M4, M5, M6, M7
REDSTONE	RR1, RR2, RRCORR23
REEDSBURG	R1, R2
ROCK SPRINGS	RS1, RS2, RS3
WHITE MOUND	WM1, WM2, WM3, WM4, WM5, WM6, WM7
WINFIELD	W1, W2, W3, W5, W6

Section 3: Certification

As the individual authorized of the snowmobile club listed above in "Section 1: Information; Snowmobile Club", of the Sauk County Snowmobile Trail System, described as the portion listed above in "Section 2: Trail IDs", by my signature, I hereby certify that all fence openings have been completed, gates have been inspected and/or opened, the required signs and/or markers have been installed and the trail section has been developed to acceptable safety standards and in accordance with trail specifications of the Sauk County Land Resources and Environment Department, Parks and Recreation Services.

Signature of Authorized Individual

Date Prepared



SAUK COUNTY ATV/UTV TRAIL DEVELOPMENT AND MAINTENANCE CONTRACT

This Contract made this 19th day of March 2024, by and between the County of Sauk, a political subdivision of the State of Wisconsin, hereinafter referred to as "County", and the Sauk Ridge Runners, Inc., a private ATV/UTV club corporation, hereinafter referred to as "Contractor".

WITNESSETH:

WHEREAS, the County wishes to ensure that ATV/UTV trails within Sauk County are developed and maintained in a suitable fashion to ensure that the trails are safe and enjoyable for use by the public; and,

NOW THEREFORE, in consideration of the mutual covenants and agreements contained herein, the parties hereby agree as follows:

- 1. Communications.** The Contractor shall designate one elected official from Sauk Ridge Runners, Inc., as set forth below, to be the point of contact for the County related to this contract. The designated elected club member shall be the only person to contact the County related to this contract and shall be the sole club member that the County is required to communicate with regarding this contract. This contract provision is intended to regulate all routine communications between the Contractor and the County. The Contractor may change their designated representative with a written amendment to this contract. All legal notices to the County shall be sent to the Sauk County Clerk.

Designated Elected Official from Sauk Ridge Runners, Inc. Information:

Name: _____

Email address: _____

Phone number: _____

- 2. Scope of Land Area Covered by Contract.** This contract shall apply to the ATV/UTV trails described and known as the Sauk County ATV/UTV Trail System, hereinafter referred to as "Trails", estimated at approximately 0.59 miles of ATV/UTV trails within the County, as specifically set forth in "Exhibit A", attached hereto and made a part hereof.
- 3. Term of Contract.** This Contract shall commence on the date noted above and shall be for the 2024-2025 ATV/UTV season, July 1, 2024 to June 30, 2025, unless sooner terminated pursuant to the "Contract Termination" provisions in this agreement.
- 4. Outdoor Motorized Recreation Trail Aids Application and Grant Award.** The County shall apply for outdoor motorized recreation trail aids by completion of the Outdoor Motorized Recreation Grant Application provided by the Wisconsin Department of Natural Resources, hereinafter referred to as "WDNR". Contractor shall submit written requests for funding by March 1 to the County. Requests received after March 1 will not be considered for the ATV/UTV season pursuant to the terms identified in this agreement.

Completion of WDNR forms is required under Wisconsin Statutes 23.09(26) and 23.33 and failure to complete said forms will result in denial of financial assistance.



The County shall annually request, by resolution, the authorization of the Sauk County Board of Supervisors to participate in the State of Wisconsin Motorized Recreation Grant Program.

In the event that funding is awarded to the County, the County shall review the grant agreement with the WDNR. If the grant agreement is desirable to the County, the County shall return a copy of the signed agreement to the WDNR.

County shall apply for supplemental funding if desired by Contractor if funding is available through the WDNR.

- 5. Payment.** Payment to the Contractor by the County will be based upon submittal of monthly invoices, provided to the Department by the fourth Wednesday of each month. The invoice shall include an itemized listing of invoices paid by the Contractor (the receipts) and one lump sum for work reports, based upon time expended. The invoice shall also include copies of each paid invoice (receipt) and work reports. Invoices (receipts) and work reports shall be sent electronically to the Land Resources and Environment Department – Parks and Recreation Area.

Payment shall be made at rates in accordance with the Equipment and Labor Rate provisions adopted by the Off Road Vehicle Advisory Council for the current ATV/UTV season, as specifically set forth in "Exhibit B", attached hereto and made a part hereof.

All representatives of the County providing labor and/or supplies to the ATV/UTV program shall prepare work and expense reports.

The Contractor shall meet all of the requirements contained within this contract. County shall withhold payment if the Contractor fails to meet the specifications listed in this contract. Once the Contractor meets all specifications and requirements of this agreement, the County shall submit payment within forty-five (45) days.

The County shall request reimbursement for the grant by completing and submitting the Grant Payment Request & Worksheet provided by the WDNR.

- 6. Equipment, Tools and Labor.** Contractor agrees to furnish all tools, equipment, and labor necessary to maintain and perform all work as specified under the terms of this contract.
- 7. Material.** Contractor shall furnish all signs, posts, gates and related materials necessary for the development and maintenance of the trail system.
- 8. Signs.** Contractor agrees to erect, replace and maintain all signs consistent with standards specified in the applicable Wisconsin Statutes, the Wisconsin Administrative Code and regulations promulgated by the WDNR.
- 9. Maintenance and Land Use Agreements.** Contractor agrees to perform all brushing, dragging, litter removal, and clean-up necessary to prepare the Trail to meet the specifications established by the WDNR in order to qualify the Trail for use. The Contractor shall annually provide the County with a Trail System Land Use Certification Form ("Exhibit C"), certifying that all landowners have been contacted verbally, electronically or with a signed contract and have granted permission to use their land and/or all necessary private property easements, leases, permits or other appropriate agreements have been secured for ATV/UTV trail use. The County shall maintain copies of all land use agreements, update a listing of all landowners annually, and verify that all land use agreements are secured. County shall notify Contractor



of any absent land use agreements, and the Contractor shall provide absent land use agreements within one (1) month of notice. The County shall annually send land use certification(s) to the WDNR.

10. Trail Opening and Closing. The Trail system shall be considered open year-round. All signs, gates, markers and related items shall be in place and the trail shall be maintained in a safe operating condition at all times. The Contractor shall annually provide the County with a Trail System Opening Certification Form ("Exhibit D") certifying that all fence openings have been completed, gates have been inspected and/or opened, the required signs and/or markers have been installed and the trail section has been developed to acceptable safety standards and in accordance with trail specifications established by the WDNR, before the Trail system is opened to the public. County shall annually send opening certification(s) to the WDNR.

The Contractor will determine if conditions are, or are not, suitable for ATV/UTV use and will open and close the trails accordingly. Contractor shall notify County of trail opening and trail closing at least one (1) hour prior to trail opening and trail closing. The County will maintain a record of trail openings and closures.

11. Safety Procedures – Equipment. Contractor shall attach a blinking light on top of the vehicle used while developing and/or maintaining trails and shall have headlights, taillights, and blinking lights on and working at all times. All equipment and vehicles shall be clearly marked with "Slow Moving Vehicle" signs to safeguard other Trail users.

The County shall randomly inspect trails annually. The County shall inform Contractor of any adverse determination regarding the trails and allow the Contractor an opportunity to correct any deficiencies or develop the trails to the acceptable safety standards, in accordance with the trail specifications established by the WDNR immediately after notice.

12. Independent Contractor Status. The Contractor is an independent contractor and not an agent or employee of the County. The Contractor shall placard or otherwise mark its equipment with the Contractor's name on both sides of its equipment.

13. Indemnification. The Contractor agrees to save, hold harmless, defend and indemnify the County and the State of Wisconsin and all its officers, employees and agents, against any and all liability claims, costs of whatever kind and nature, for injury to or death of any person or persons, and for loss or damage to any property, County, State or other, occurring in connection with or in any way incident to or arising out of the occupancy, use, service, operation or performance of the work in connection with this Contract.

14. Insurance Coverage. The Contractor, at their expense, shall maintain public liability insurance issued by an insurance company licensed to do business in the State of Wisconsin, including bodily injury and property damage coverage insuring the Contractor and County with minimum coverage as follows: liability coverage for its officers, employees, and agents with policy limits at minimum of \$1,000,000 single limit and \$3,000,000 aggregate and workers compensation insurance in the following amounts:

- a. Coverage A: Limits – Statutory
- b. Coverage B: Employer's Liability Limits
- c. Bodily Injury by Accident - \$100,000 each accident minimum
- d. Bodily Injury by Disease - \$100,000 each employee minimum
- e. Bodily Injury by Disease - \$500,000 policy limit minimum



The County shall be named as an additional insured on all insurance policies except workers compensation. The certificate shall provide for a ten-day written notice to the County in the event of cancellation or material change of coverage. The Contractor shall annually provide the County with acceptable certificates of insurance, from a corporation licensed in the State of Wisconsin to provide insurance. County shall annually send insurance certification(s) to the WDNR and other appropriate entities.

- 15. Conduct.** The Contractor agrees that its agents, employees and representatives shall conduct themselves in a decent, orderly, and business-like manner at all times while performing under this Contract.
- 16. Compliance.** Contractor agrees to follow and comply with the applicable Wisconsin Statutes, Wisconsin Administrative Code, the regulations promulgated by the State of Wisconsin Department of Natural Resources, and of Sauk County Code of Ordinances.
- 17. Amendment of Contract.** This contract may only be amended, changed, or modified in writing by mutual agreement of the parties.
- 18. Assignment.** Contractor shall not assign, subcontract, or otherwise transfer this Contract except with the express written approval of the County.
- 19. Contract Termination.** Notwithstanding any provision herein, the County reserves the right to terminate this Contract, for cause, upon seven (7) days written notice to the Contractor if the County determines that the Contractor's operation is unsatisfactory in any respect or if the County determines that the Contractor has failed, neglected, or refused to comply with the terms of this Contract. This contract is also subject to the availability of funding and shall be terminated in the event that funding for the required services is not available. In such event, the County shall notify the Contractor of such termination due to funding constraints.
- 20. Form of Contract.** Section 16.76(1) of the Wisconsin Statutes, is incorporated by reference into this contract, as applicable.
- 21. Applicable Law.** This Contract shall be construed and governed by the rules and laws of the State of Wisconsin.
- 22. Notices.** Any notice required or permitted under this Agreement shall be in writing, shall reference this Agreement and will be deemed given: (i) upon personal delivery to the appropriate address; or (ii) three (3) business days after the date of mailing if sent by certified or registered mail; or (iii) one (1) business day after the date of deposit with a commercial courier service offering next business day service with confirmation of delivery.

All communications shall be sent to the contact information set forth below or to such other contact information as may be designated by a Party by giving written notice to the other Party pursuant to this provision:

To Contractor: Sauk Ridge Runners
S4232 Barreau Road
LaValle, WI 53941



To County: Sauk County Clerk
505 Broadway
Baraboo, WI 53913

With a copy to: Sauk County Parks Department
S7995 White Mound Drive
Hillpoint, WI 53937

Nothing in this paragraph is intended to disrupt routine communications between the parties.

- 23. No Construction Against Either Party.** This agreement is the product of negotiations between the parties and was either reached with the advice of legal counsel or the opportunity to obtain legal counsel and shall not be construed against either party.
- 24. Multiple Originals.** This contract may be executed in multiple originals, each of which together shall constitute a single agreement.
- 25. Captions.** The parties agree that in this contract, captions are used for convenience only and shall not be used in interpreting or construing this contract.
- 26. Statutory Protections.** It is agreed by the parties that nothing in this contract, including but not limited to indemnification and hold harmless clauses, shall in any way constitute a waiver on the part of the Employer of any immunity, liability limitation or other protection available to the Employer under any applicable statute or other law. To the extent that any provision of this contract is found by any court of competent jurisdiction to conflict with any such legal protection, then whichever protections, either statutory or contractual, provide a greater benefit to the Employer shall apply unless the Employer elects otherwise.
- 27. Open Records Law Compliance.** Contractor understands and agrees that, because Employer is a party to this contract, provisions of the Wisconsin Open Records Law and other laws relating to public records may apply to records kept by Contractor and/or the Employer. Contractor agrees to fully comply with such laws, and to cooperate with Employer in its compliance with such laws. Cooperation shall include, but not be limited to, the provision of records, or copies of records to Employer or others upon the request of Employer. Compliance and cooperation of Contractor shall be at its sole cost and expense.
- 28. Relationship of Parties.** Nothing in, or done pursuant to, this contract shall be construed to create the relationship of employer and employee, principal and agent, partners, or a joint venture between Employer and Contractor. This contract does not create an employee/employer relationship between the parties. It is the parties' intention that the Contractor will be an independent contractor and not the County's employee for all purposes, including, but not limited to, the application of the Fair Labor Standards Act minimum wage and overtime payments, Federal Insurance Contribution Act, the Social Security Act, the Federal Unemployment Tax Act, the provisions of the Internal Revenue Code, the state revenue and taxation law, the state workers' compensation law and the state unemployment insurance law. This contract shall not be construed as creating any joint employment relationship between the Contractor and the Employer, and the Employer will not be liable for any obligation incurred by Contractor including but not limited to unpaid minimum wages, overtime premiums, unemployment insurance benefits, worker's compensation benefits, health insurance, health benefits, disability benefits, or retirement benefits. Contractor is not entitled to receive any benefits from Employer or to participate in any Employer benefit plan.



29. Competence, Solvency. Contractor warrants and represents that it is sufficiently experienced and competent to provide, perform and complete all services in full compliance with and as required by or pursuant to this contract. Contractor represents and warrants that it is financially solvent, and has the financial resources necessary to provide, perform and complete the duties and functions in full compliance with and as required by this contract. Contractor shall provide, perform and complete all services contemplated by this contract in an expeditious and proper.

30. Electronic Signing. It is agreed by the parties that either party or both may, by email, provide the other party with a copy of this contract, in PDF form or otherwise, showing the signatures of, or on behalf of the sending party, with such signatures being as binding as original signatures, regardless of whether the other party signs in the same fashion, or by using original ink signatures. For the purposes of this section, "signatures" may be original written signatures, photocopies of signatures, or signatures added to a contract or through the addition by a signing party of a typed or electronically added signature.

IN WITNESS WHEREOF, the parties hereto have executed this Contract on the date set forth herein.

COUNTY OF SAUK

Administrator, Sauk County

Date

SAUK RIDGE RUNNERS ATV/UTV CLUB

President

Date

Secretary

Date

Sauk County ATV/UTV Routes and Trails



February 13, 2023

ATV Routes

- Sauk County - ATV Off-Road Trails
- Sauk County - City & Village Street ATV Routes
- Sauk County - Town Road ATV Routes
- Sauk County - County & State Highway ATV Routes
- Juneau County ATV Routes
- Richland County ATV Routes
- Road Centerlines - TOWN
- Road Centerlines - MUNI
- Road Centerlines
- Interstate
- Federal
- State
- County
- Town
- Muni
- Alley
- Private-Named
- Private
- Ramp
- Municipal Boundaries

1:9,028

0 0.07 0.15 0.3 mi

0 0.13 0.25 0.5 km

Land Information GIS, Sauk County Land Information/ GIS

Equipment and Labor Rates for 2023-24 Season
Adopted by Snowmobile Recreation Council & Off-Road Vehicle Council

I. SNOW TRAIL GROOMING EQUIPMENT RATES - All rates include power unit, grooming drag & operator(s).

Class	Description	Rate/Hour
AAA	All heavy duty tracked units constructed specifically for snow grooming with a minimum of 150 horsepower and capable of pulling on a sustained basis a hydraulically operated grooming drag of at least 7'6" (90 inches) frame width. OR All fully tracked agricultural tractors with a minimum of 125 horsepower. OR Trucks: minimum 1-ton (4-wheel drive), minimum payload of 3,500 lbs., fully-tracked with a minimum manufactured 15,000 GVW track system.	\$5 more than AA AAA1 - \$100 AAA2 - \$90 AAA3 - \$80 AAA4 - \$70
AA	All heavy duty tracked units constructed specifically for snow grooming having between 149 - 106 horsepower and capable of pulling on a sustained basis a hydraulically operated grooming drag of at least 7'6" (90 inches) frame width. OR All fully tracked agricultural tractors with 106 – 124 horsepower.	\$5 more than A AA1 - \$95 AA2 - \$85 AA3 - \$75 AA4 - \$65
A	All wheeled or half-track agricultural tractors with all-wheel drive, minimum of 105 horsepower and capable of pulling on a sustained basis a hydraulically operated grooming drag of at least 7'6" (90 inches) frame width.	A1 - \$90 A2 - \$80 A3 - \$70 A4 - \$60
1	Drag is a minimum of 11'6" (138 inches) frame width with a minimum weight of 4,000 pounds and a length of at least 20 feet including snow packing pan but excluding the tongue.	Wings that fold down outside the main frame do not increase the drag width for funding purposes. Class is based on static frame dimensions.
2	Drag is a minimum of 9'6" (114 inches) frame width with a minimum weight of 3,000 pounds and a length of at least 18 feet including snow packing pan but excluding the tongue.	
3	Drag is a minimum of 7'6" (90 inches) frame width with a minimum weight of 2,000 pounds and a length of at least 18 feet including snow packing pan but excluding the tongue.	
4	Drag is a minimum of 7'6" (90 inches) frame width.	
B	All medium duty (including pick-up trucks) tracked units constructed or adapted specially for snow grooming and capable of pulling on a sustained basis a grooming drag 5'10" to 7'5" (70-89 inches) frame width. OR All wheel type agricultural tractors with all-wheel drive or four-wheel drive assist with a range of 65-104 horsepower.	\$50.00
C	All light duty power units constructed or adapted for snowmobile trail grooming and capable of pulling on a sustained basis a grooming drag 4' to 5'9" (48-69 inches) frame width. Examples of the class of power units would include: ATVs/UTVs and snowmobiles. This class also includes all equipment not addressed in other classes.	\$35.00

Notes regarding correct rates for grooming equipment:

1. A Class A power unit pulling either an 11'6" or 9'6" grooming drag that does **not** meet the specifications for either 1, 2 or 3 drags will be placed at level 4 for rate purposes.
2. A Class A power unit **not** pulling a 7'6" grooming drag will be placed in Class B for rate purposes.
3. A Class B power unit **not** pulling a 5'10" grooming drag will be placed in Class C for rate purposes.
4. A power unit will **not** be placed in a higher class if it pulls a larger grooming drag than specified for the class.
5. Modifications to the drag must maintain original cutting and packing function as designed. Modifications made outside the main frame will not increase the funding class.
6. Those winged drags that were previously funded and met the specifications as stated prior 2022-23 season may continue to be funded at their previous classification (drag dimensions included) for a period of 10 years (through 2031-32)
7. Groomer time spent traveling on a route that is an integral part of a single funded trail may be funded at a rate of 50% of the assigned groomer rate, as non-grooming transport time. DNR will determine if route is integral to the funded trail.

Equipment and Labor Rates for 2023-24 Season
Adopted by Snowmobile Recreation Council & Off-Road Vehicle Council

II NON-GROOMING MAINTENANCE LABOR AND EQUIPMENT RATES A

MAINTENANCE LABOR (For other than trail grooming)

A labor rate of **\$9.00** per hour maximum is established for all non-grooming labor performed in **WINTER** trails, or **\$12.00** per hour maximum on any **SUMMER ATV/UTV** trails under the maintenance agreement by snowmobile clubs and or other similar organizations with the sponsoring county. Maintenance will generally include mowing and brushing, sign and post replacement, plowing of parking lots and roads, shelter and toilet maintenance and normal repair and replacement of structures and facilities.

The allowable labor rate for county employees and others included in labor contracts will be as specified by contract.

B EQUIPMENT RATES (For other than trail grooming)

The following schedule is based on frequently used pieces of equipment for non-grooming maintenance. The Department of Transportation rates are considered when these rates are reviewed each year.

Equipment rates for pieces of equipment not found on this list will be found in the DOT rates. Unless specified otherwise, these rates for equipment are based on hourly use. These rates do **not** include the operator. Where the Department of Transportation issues rates that reflect an adjustment due to fuel rates, these rates shall be the rates utilized for the season.

Class	Description	Rate
101	All trucks pickups	\$16.00
105	All trucks single axle dual-tire over 26,000 lbs.	\$56.00
128	All Trucks, tandem, tri, quad axle	\$60.00
203	All Tired tractors & All skid-steers up to 49 hp	\$28.00
205	All Tired tractors & All skid-steers 50-99 hp	\$33.00
206	All Tired tractors & All skid-steers 100-149 hp	\$43.00
207	All Tired tractors & All skid-steers 150 hp and up	\$52.00
215	All Fully Tracked tractors & dozers up to 99 hp	\$48.00
217	All Fully Tracked tractors & dozers 100 - 149 hp	\$53.00
218	All Fully Tracked tractors & dozers 150 hp and up	\$82.00
401	Air compressor all types	\$14.00
410	Motorized mower over 23" (self-contained or pull behind)	\$15.00
413	Mower—tractor mounted	\$16.00
414	Sickle attached to power unit	\$16.00
490	Trailer less than 1 ton (use mfr. rated capacity)	\$11.00
491	Trailer 1-4 tons (use mfr. rated capacity)	\$15.00
493	All Trailers over 4 ton	\$26.00
550	Rubber tired Backhoe (80 HP and over) was # 250	\$55.00
555	Excavator Track type (less than 100 HP)	\$48.00
558	Excavator Track type (100 - 149HP)	\$52.00
559	Excavator Track type (150HP and over)	\$65.00
802	Portable electric generator (all types)	\$18.00
902	Chipper self-contained (minimum 25 hp)	\$33.00
914	Chain Saw, pole saw, power pruner, brush saw, weed eaters	\$6.50
914T	Trailblazer brush cutter (attachment)	\$10.50
915	Auger (attachment for tractor/ skid steer), Post pounder-hydraulic	\$32.00

Equipment and Labor Rates for 2023-24 Season
Adopted by Snowmobile Recreation Council & Off-Road Vehicle Council

916	Hand-held motorized post-hole digger	\$13.00
919	Disc/spring tooth harrow/cultimulcher/cultipacker/rototiller	\$11.00
922	Welder	\$4.00
932	Brush Cutter - hydraulic driven/Fecon head	\$30.00
940	Brush Cutter—PTO driven	\$23.00
953	Boom for brush cutter	\$15.50
9042	Gas drill	\$5.00
9145	Snowmobile/ATV/UTV	\$19.00
9152	Stump grinder (all) hydraulic/self powered	\$36.00
9205	Rear blade/box scraper/pull behind grader/packing pan/rollers	\$8.00
9406	Chipper, PTO driven	\$25.00

ATV Summer Supplement
Adopted by the Off Road Vehicle Advisory Council

Spring/Summer/Fall Trail Grooming Drags

Class	Description	Rate Per Hour
Class 1	Drag is a minimum of 7'6" in frame width with a minimum length of at least 16' excluding the tongue. Drag contains at least 2 sets of replaceable cutting blades	\$11.00
Class 2	Drag is a minimum of 7'6" in frame width	\$9.00

Example of Class 1 Drag



Sauk County Land Resources and Environment Department
 Attn: Parks and Recreation
 S7995 White Mound Drive
 Hillpoint, WI 53937
 (608) 355-4800

Trail System Land Use Certification

Form: LUC2018

Notice: Completion of this form is required under the Development and Maintenance Contract between the Sauk County Land Resources and Environment Department and the Sauk Ridge Runners, Inc. Due date is April 15 of each year.

Instructions: Complete this form after all landowners in your club section have been contacted and have granted permission to use his/her land and/or all necessary private property easements, leases, permits or other appropriate agreements have been secured for ATV/UTV trail use. Send completed form to the Sauk County Land Resources and Environment Department, Attn: Parks and Recreation, S7995 White Mound Drive, Hillpoint, WI 53937.

Section 1: Information

Year of ATV/UTV Season	ATV/UTV Club Sauk Ridge Runners
------------------------	------------------------------------

Printed Name of Individual Authorized to Act on Behalf of Club

Mailing Address for Club

City	State	Zip Code
------	-------	----------

Telephone Number of Authorized Individual

Email Address of Authorized Individual

Section 2: Trail IDs

List all County-funded trails for the ATV/UTV club listed above

SRR2

SAUK RIDGE	SRR2

Section 3: Certification

As the individual authorized of the ATV/UTV club listed above in "Section 1: Information; ATV/UTV Club", of the Sauk County ATV/UTV Trail System, described as the portion listed above in "Section 2: Trail IDs", by my signature, I hereby certify that all landowners in my club section have been contacted verbally, electronically or with a signed contract and have granted permission to use his/her land and/or all necessary private property easements, leases, permits or other appropriate agreements have been secured for ATV/UTV trail use for the upcoming ATV/UTV season.

 Signature of Authorized Individual

 Date Prepared

Sauk County Land Resources and Environment Department
 Attn: Parks and Recreation
 S7995 White Mound Drive
 Hillpoint, WI 53937
 (608) 355-4800

Trail System Opening Certification

Form: OC2018

Notice: Completion of this form is required under the Development and Maintenance Contract between the Sauk County Land Resources and Environment Department and the Sauk Ridge Runners, Inc. Due date is April 15 of each year.

Instructions: Complete this form after all fence openings have been completed, gates have been inspected and/or opened, the required signs and/or markers have been installed, and the trail is in a safe operating condition. Send completed form to the Sauk County Land Resources and Environment Department, Attn: Parks and Recreation, S7995 White Mound Drive, Hillpoint, WI 53937.

Section 1: Information

Year of ATV/UTV Season	ATV/UTV Club Sauk Ridge Runners
------------------------	------------------------------------

Printed Name of Individual Authorized to Act on Behalf of Club

Mailing Address for Club

City	State	Zip Code
------	-------	----------

Telephone Number of Authorized Individual

Email Address of Authorized Individual

Section 2: Trail IDs

List all County-funded trails for the ATV/UTV club listed above

SRR2

SAUK RIDGE	SRR2

Section 3: Certification

As the individual authorized of the ATV/UTV club listed above in "Section 1: Information; ATV/UTV Club", of the Sauk County ATV/UTV Trail System, described as the portion listed above in "Section 2: Trail IDs", by my signature, I hereby certify that all fence openings have been completed, gates have been inspected and/or opened, the required signs and/or markers have been installed and the trail section has been developed to acceptable safety standards and in accordance with trail specifications of the Sauk County Land Resources and Environment Department, Parks and Recreation Services.

 Signature of Authorized Individual

 Date Prepared



SAUK COUNTY OFF-HIGHWAY MOTORCYCLE TRAIL DEVELOPMENT, MAINTENANCE AND EVENT CONTRACT

Contract by and between Sauk County ("County") and Driftless Dual Sport Riders ("Contractor") as follows:

WHEREAS, Sauk County annually participates in maintaining, acquiring, insuring or developing lands for public motorized trail use. In doing so, these public motorized trails are eligible for grant funds through the Wisconsin Department of Natural Resources; and

WHEREAS, the aforementioned grant program funds 100% of the cost for the acquisition, development, insurance, and maintenance of public trails. Funding for the program comes from registration fees and a portion of tax on gasoline; and

WHEREAS, The Driftless Dual Sports Riders contacted the County, requesting assistance with a grant application for a one-two day special event to be held at the Sauk Prairie State Recreation Area; and

WHEREAS, Under the concept of re-purposing as described in the Master Plan, County is facilitating the grant on behalf of the local OHM club by requesting funds to cover the cost of a one-two day special event for Off-Highway Motorcycle riders in 2024 ("Event"); and

WHEREAS, under the Master Plan guidelines the club requests to re-purpose up to 50% of the established biking, equestrian and public roads within the Sauk Prairie State Recreation Area for the Event; and

WHEREAS, the County has been awarded a grant from the Wisconsin DNR to facilitate the Event, which would be used to reimburse the OHM club for actual expenses incurred such as insurance and signage, and also covers County staff time.

NOW, THEREFORE, based on the good and valuable consideration stated herein, and other good and valuable consideration, the receipt and sufficiency of which is acknowledged, the parties agree as follows:

1. Duties of Contractor. Contractor shall be responsible for the following:

- a. Notify the County Land Resources and Environment Department of the dates the event is scheduled.
- b. The Event shall be held no later than November 30, 2024.
- c. Notify the County upon completion of the work, meet with the County representative on-site to review the trails. If the clean-up is found to be deficient, or if the trails need repair due to the event, Contractor shall clean up and make repairs as noted in the written notice provided by the County.
- d. The Contractor will be responsible for site safety during all phases of the Event. Contractor shall ensure that all trails to be used for the Event are signed with appropriate warning signs and blocked off to prevent public access.
- e. All Federal, State, County, and local laws, permits, and regulations are to be adhered to by the contractor. No deviations from the specifications allowed unless the County agrees. The County is not aware of any permits specific to this project.
- f. Once the Event is completed and all clean-up and/or repair work is approved by the County, all leftover materials, waste, tools and equipment must be removed from the Event site, trail and area.



2. Duties of the County. The County shall be responsible for the following:

- a. Manage the grant funds and reporting to the State of Wisconsin DNR.
- b. Make reimbursement for expenses to the Contractor within 45 days of reimbursement requests.

3. Communications. The Contractor shall designate one elected official from Driftless Dual Sport Riders, as set forth below, to be the point of contact for the County related to this contract. The designated elected club member shall be the only person to contact the County related to this contract and shall be the sole club member that the County is required to communicate with regarding this contract. This contract provision is intended to regulate all routine communications between the Contractor and the County. The Contractor may change their designated representative with a written amendment to this contract. All legal notices to the County shall be sent to the Sauk County Clerk.

Designated Elected Official from Driftless Dual Sport Riders Information:

Name: _____

Email address: _____

Phone number: _____

4. Notices. Any legal notices required by this Agreement shall be made in writing to the address specified below:

County: County Clerk
505 Broadway
Baraboo, WI 53913

With a copy to: Sauk County Land Resources and Environment
Attn: Jekka Alt
57995 White Mound Drive
Hillpoint, WI 53937

Contractor: Driftless Dual Sport Riders
125 S. Monroe Street
Stoughton, WI 53589

Nothing contained in this section shall be construed to restrict the transmission of routine communications between representatives of the parties.

5. Insurance. During the term of this Agreement, Contractor shall maintain the types and amounts of insurance in the attached insurance certificate (Exhibit 1).

- a. Certificates of insurance are required for all policies. The Certificates of General and Automobile Liability Insurance must name the County as an additional insured on the policy and must require that a thirty (30) day cancellation notice be given to the County. An updated copy of the Certificate must be provided anytime a change is made to any policy.



- 6. Delay in Performance.** Neither party shall be considered in default of this Agreement or any Task Order for delays in performance caused by circumstances beyond the reasonable control of the nonperforming party. For purposes of this Agreement, such circumstances include, but are not limited to, abnormal weather conditions, floods, earthquakes, fire, epidemics, war, riots, and other civil disturbances, strikes, lockouts, work slowdowns, and other labor disturbances, sabotage, judicial restraint, and delay in or inability to procure permits, licenses or authorizations from any local, state or federal agency for any of the supplies, materials, accesses, or services required to be provided by either party under this Agreement or any Task Order. The nonperforming party shall be granted a reasonable extension of time for any delay in its performance caused by any such circumstances.
- 7. Governing Law, Jurisdiction and Venue.** This Agreement shall be construed and interpreted in accordance with the laws of the State of Wisconsin. The parties hereby irrevocably submit to the jurisdiction of the state courts of the State of Wisconsin for the purpose of any suit, action or other proceeding arising out of or based upon this Agreement. The parties further agree that the venue for any legal proceedings related to this Agreement shall be Sauk County, Wisconsin.
- 8. Survival.** The warranties, representations and covenants of this Agreement shall survive completion of the Services under this Agreement or any termination of this Agreement.
- 9. Waiver.** A waiver by either of the parties of any breach of this Agreement shall be in writing. Such a waiver shall not affect the waiving party's rights with respect to any other or further breach.
- 10. Severability.** The invalidity, illegality or unenforceability of any provision of this Agreement or the occurrence of any event rendering any portion or provision of this Agreement void shall in no way affect the validity or enforceability of any other portion or provision of this Agreement or any Task Order. Any void provision shall be deemed severed from this Agreement and the balance of this Agreement shall be construed and enforced as if it did not contain the particular portion or provision held to be void. The parties further agree to amend this Agreement to replace any stricken provision with a valid provision that comes as close as possible to the intent of the stricken provision. The provisions of this Article shall not prevent this entire Agreement from being void should a provision which is of the essence of this Agreement be determined void.
- 11. Integration.** This Agreement represents the entire and integrated agreement between the parties. It supersedes all prior and contemporaneous communications, representations and agreements, whether oral or written, relating to the subject matter of this Agreement.
- 12. Assignment.** Neither party shall assign any rights or duties under this Agreement without the prior written consent of the other party.
- 13. Successors and Assigns.** The parties each bind themselves and their successors, executors, administrators, permitted assigns, legal representatives and, in the case of a partnership, the partners, to the other party to this Agreement and to the successors, executors, administrators, permitted assigns, legal representatives and partners of such other party in respect to all provisions of this Agreement.
- 14. No Construction Against Either Party.** This Agreement is the product of negotiations between the parties and was either reached with the advice of legal counsel or the opportunity to obtain legal counsel, and shall not be construed against either party.



- 15. Multiple Originals.** This contract may be executed in multiple originals, each of which, together shall constitute a single agreement.
- 16. Captions.** The parties agree, that in this contract, captions are used for convenience only and shall not be used in interpreting or construing this contract.
- 17. No Partnership or Joint Venture.** This contract shall not in any way be deemed to create a partnership or joint venture between the parties to the Agreement.
- 18. Statutory Protections.** It is agreed by the parties that nothing in this contract, including but not limited to indemnification and hold harmless clauses, shall in any way constitute a waiver on the part of the County of any immunity, liability limitation or other protection available to the County under any applicable statute or other law. To the extent that any provision of this contract is found by any court of competent jurisdiction to conflict with any such legal protection, then whichever protections, either statutory or contractual, provide a greater benefit to the County shall apply unless the County elects otherwise.
- 19. Open Records Law Compliance.** Contractor understands and agrees that, because County is a party to this contract, provisions of the Wisconsin Open Records Law and other laws relating to public records may apply to records kept by Contractor. Contractor agrees to fully comply with such laws, and to cooperate with County in its compliance with such laws. Cooperation shall include, but not be limited to, the provision of records, or copies of records to County or others upon the request of county. Compliance and cooperation of Contractor shall be at its sole cost and expense.
- 20. Amendment.** No amendment of this contract shall be binding unless in writing and signed by all of the parties.
- 21. Standard of Care.** The same degree of care, skill, and diligence shall be exercised by Contractor in the performance of its duties as is ordinarily possessed and exercised by a member of the same profession, currently practicing, under similar circumstances.
- 22. Equal Employment Opportunity.** Contractor hereby affirms its support of affirmative action and that it abides by the provisions of the "Equal Opportunity Clause" of Section 202 of Executive Order 11216 and other applicable laws and regulations. Contractor affirms its policy to recruit and hire employees without regard to race, age, color, religion, sex, sexual preference/orientation, marital status, citizen status, national origin or ancestry, presence of a disability or status as a veteran, including a veteran of the Vietnam era, membership in the national guard or reserve components of the military of the United States, political affiliation, or any other legally protected status. It is Contractor's policy to treat employees equally with respect to compensation, advancement, promotions, transfers and all other terms and conditions of employment. Contractor further affirms completion of applicable governmental employer information reports including the EEO-1 and VETS-100 reports, and maintenance of a current Affirmative Action Plan as required by Federal regulations.
- 23. Gratuities – Kickbacks – non-collusion.** It shall be a breach of this contract and subsequent amendments for contractor to offer, give, or agree to give anything of pecuniary value or to make an offer for employment to any elected official, employee, or former employee in connection with this Agreement. Prohibited conduct shall include, but is not limited by enumeration, acts or attempts to influence: any decision, approval, disapproval, recommendation, preparation of any part of a program requirement or a purchase request, the contents of any



specification or procurement standard, rendering of advice, investigation, auditing, or in any other advisory capacity in any proceedings or application, request for ruling, determination, claim or controversy, or other particular matter pertaining to any program requirement or contract, subcontract, or any solicitation or proposal therefore.

24. Time of the Essence. Except as otherwise specifically stated herein, time is of the essence with respect to all provisions of this contract that specify a time for performance.

{READ THE NEXT SECTION CAREFULLY, YOU HAVE THE RIGHT TO HAVE AN ATTORNEY REVIEW THIS CLAUSE}

25. Indemnification and hold Harmless. Contractor shall at all times indemnify, defend and save harmless, the County and its supervisors and employees from any and all causes of action, demands, liability, claims, damages, losses, costs and expenses, including but not limited to reasonable attorney's fees, by reason of loss or damage to any property or bodily injury to any person, including but not limited to death, as a direct or indirect result of the performance by Contractor of its duties hereunder or as a result of participation in the preparation, clean-up or participation in the Event, and as the result of any action or omission of Contractor.

BY SIGNING BELOW THE PARTIES AFFIRM AND ACKNOWLEDGE THAT: they have read and understand Agreement and its Attachments, if any; they have authority to enter into Agreement on behalf of the corporation or other entity they are signing for; they are knowingly, freely, and voluntarily entering into Agreement; and that they accept and agree to be bound by the terms and conditions of Agreement and its Attachments, if any, as outlined in Agreement:

COUNTY OF SAUK

Administrator, Sauk County

Date

DRIFTLESS DUAL SPORT RIDERS

President

Date

Secretary

Date

NOTEPAD:HOLDER CODE
INSURED'S NAME **American Motorcyclist**AMERI-8
OP ID: NCPAGE 2
Date 5/3/2023**Type of Insurance: Commercial General Liability****Policy Number: PK202300026671****Insured: AMERICAN MOTORCYCLIST ASSOCIATION, INC., AMA DISTRICT ORGANIZATIONS, CLUBS and PROMOTERS****Additional Insureds, in accordance with policy terms and conditions:**

- A. Any managers, owner, or lessor of premises used by the named insured;
 - B. Any person or organization sponsoring racing vehicles or sponsoring racing vehicle drivers;
 - C. Any person or organization sponsoring your activities or events;
 - D. Racing vehicle owners, racing vehicle drivers and racing vehicle crew members; volunteers
 - E. Persons or organizations (other than drivers, crew members, racing vehicle owners, sponsors, volunteers, or managers or lessors of premises) if required by contract.
 - F. Any state or governmental agency or subdivision or political subdivision - permits or authorizations
 - G. Any lessor of leased equipment when required in lease agreement with you
- H. Wisconsin DNR and it's employees S5975 Park Road Baraboo, WI 53913 - Land owner
I. Sauk County Sauk County Parks Dept S7995 White Mound Drive, Hillpoint, WI 53937 - Grant writer

EVENT DATES*: 10/1/2023

PRACTICE: N/A

ADDITIONAL CAMPING: N/A

ADDITIONAL SET-UP: N/A

ADDITIONAL TEAR DOWN: N/A

511

*Includes coverage for set-up and camping day before the Event and tear down the day after the Event.

RESOLUTION # 18 - 2024

Resolution to donate the fire hose and wagon from the historic 1921 firehouse at the Sauk County Farm to the Reedsburg Area Historical Society and Pioneer Village.

Resolution offered by the Land Resources and Environment Committee

Resolved by the Board of Supervisors of Sauk County, Wisconsin:

BACKGROUND:

The Sauk County Land Resources and Environment Department created the 2022-2042 Sauk County Farm Property Master Plan to ensure the continued management of the site's agricultural and natural resources, preservation of its historic features, and the transformation of the space into an educational resource for the communities of Sauk County. Over the next 20 years, the County Farm is envisioned to become an important educational resource for Sauk County residents of all ages and backgrounds to learn about regenerative, profitable, and resilient agricultural practices through on-site demonstration, research, and collaborative partnerships. The master plan is centered on the following goals: to create educational opportunities for Sauk County's current and future farmers through community partnerships; utilize the space for agricultural demonstration and research; and pay homage to the history and people of the property. The County Farm will become a space where educational institutions, non-profit organizations, public agencies, and any interested person in Sauk County can converge to learn about farming and train the leaders who will carry forward our community's agricultural legacy.

Resolution No. 150-2019 adopting the 2020-2024 Sauk County Outdoor Recreation Plan was approved by the Sauk County Board of Supervisors on January 21, 2020. Objectives of the plan include donation of the original horse-drawn fire hose and wagon to a local museum or historical society for greater educational use, and the restoration and reuse of the fire house into a storage shed for the community gardens.

The Reedsburg Historical Society and Pioneer Village has an expressed interest and ability to display the original horse-drawn wagon and hose which are currently stored in the historic 1921 fire house at the Sauk County Farm. The wagon and hose would be put on display in the Sanders Building located within the Pioneer Village. They already have on display the Sauk County Farm one-room schoolhouse that was originally located near the farm from 1858-1962.

THEREFORE, BE IT RESOLVED, that the Sauk County Board of Supervisors, met in regular session, does hereby donate the original fire hose and wagon from the historic 1921 firehouse at the Sauk County Farm to the Reedsburg Area Historical Society and Pioneer Village.

Approved for presentation to the County Board by the Land Resources and Environment Committee, this 19th day of March 2024.

Consent Agenda Item: [] YES [] NO

Fiscal Impact: [] None [X] Budgeted Expenditure [] Not Budgeted

Vote Required: Majority = _____ 2/3 Majority = _____ 3/4 Majority = _____

52
53
54
55
56
57
58
59
60
61
62
63
64
65
66
67
68
69
70
71
72
73
74
75
76
77
78
79
80
81
82
83
84
85
86
87
88

The County Board has the legal authority to adopt: Yes No _____ as reviewed
by the Corporation Counsel, *[Signature]*, Date:
03.11.2024

Offered and passage moved by:

Marty Krueger Aye Nay Abstain Absent
Marty Krueger, Chair

 Aye Nay Abstain Absent
Peter Kinsman, Vice Chair

[Signature] Aye Nay Abstain Absent
Brandon Lohr

[Signature] Aye Nay Abstain Absent
Dennis Polivka

[Signature] Aye Nay Abstain Absent
Robert Spencer

[Signature] Aye Nay Abstain Absent
Valerie McAuliffe

[Signature] Aye Nay Abstain Absent
Lynn Eberl

 Aye Nay Abstain Absent
Randy Puttkamer

Fiscal Note: Representatives from the Reedsburg Historical Society estimated the value of hose
and wagon to be between \$2,500 to \$5,000. *[Signature]*

MIS Note: None.

RESOLUTION # 19-2024
AUTHORIZING THE RENEWAL OF SAUK COUNTY'S EXISTING MICROSOFT
ENTERPRISE AGREEMENT

Resolution offered by the Executive and Legislative Committee.

Resolved by the Board of Supervisors of Sauk County, Wisconsin:

BACKGROUND:

Background: Sauk County is currently enrolled in a Microsoft Enterprise Agreement (EA) and has been since 2009. An Enterprise Agreement is a three-year license agreement that provides special pricing and licensing terms for products enrolled in the agreement. Sauk County's current three-year agreement is set to renew on April 1, 2024. Under this agreement, Sauk County may purchase additional licenses, at the contracted rate, at any time during the term of the contract and is required to do so in order to maintain the correct number of licenses in compliance with the terms of the agreement. The term of this agreement is through March 31, 2027.

This renewal will upgrade the current licensing from Office365 to Microsoft365, an enterprise version of the current license model, providing improved security features and enhanced management of end-user devices with multi-factor authentication and mobile device management.

Under this agreement, Sauk County will license 595 MS Office users and 187 email-only users.

NOW, THEREFORE, BE IT RESOLVED, by the Sauk County Board of Supervisors, met in regular session, that the existing Microsoft Enterprise Agreement be renewed for a three-year term beginning April 1, 2024, at an annual cost of \$255,138 and;

BE IT FURTHER RESOLVED, that the Sauk County MIS Director be authorized to obtain additional licenses under this agreement, up to the number required to maintain compliance with said agreement, on behalf of Sauk County, and;

BE IT FURTHER RESOLVED, that the Sauk County MIS Director be delegated the authority to sign any contracts related to this renewal on behalf of Sauk County.

Approved for presentation to the County Board by the Sauk County Executive and Legislative Committee, this 19th day of March 2024.

Consent Agenda Item: [] YES [X] NO

Fiscal Impact: [] None [X] Budgeted Expenditure [] Not Budgeted

Vote Required: Majority = X 2/3 Majority = _____ 3/4 Majority = _____

The County Board has the legal authority to adopt: Yes X No _____ as reviewed by the Corporation Counsel, _____, Date:

03.13.2024 . _____

Offered and passage moved by:

51
52
53
54
55
56
57
58
59
60
61
62
63
64
65
66
67
68
69
70
71
72
73
74
75
76
77
78
79

Executive and Legislative Committee:



Timothy McCumber

Aye Nay Abstain Absent



John M. Dietrich

Aye Nay Abstain Absent

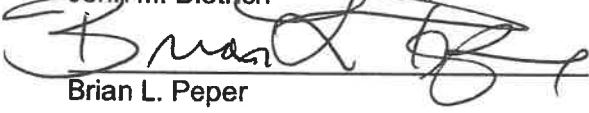

Brian L. Peper

Aye Nay Abstain Absent

Carl Gruber

Aye Nay Abstain Absent

Marty Krueger

Aye Nay Abstain Absent

Fiscal Note:

The 2024 MIS Budget Provides funding for this renewal



MIS Note:

The proposed system is cloud-based and does not require the purchase of additional hardware or infrastructure to support the use of the software.

RESOLUTION # 20 -2024

Resolution to Adopt the Public Participation Plan as part of the Sauk County 2024 Hazard Mitigation Plan Update

Resolution offered by the Executive & Legislative Committee

Resolved by the Board of Supervisors of Sauk County, Wisconsin:

BACKGROUND: Working in concert with local jurisdictions, Sauk County has initiated a project to update its countywide hazards mitigation plan to comply with the Disaster Mitigation Act of 2000. The Public Participation Plan lists the methods whereby Sauk County Emergency Management will facilitate public participation and local government involvement in the preparation, review, and adoption of the updated Sauk County Hazard Mitigation Plan.

THEREFORE, BE IT RESOLVED, by the Sauk County Board of Supervisors, met in regular session, to adopt the Multijurisdictional 2024 Hazards Mitigation Public Participation Plan (attached).

Approved for presentation to the County Board by the Executive and Legislative Committee, this 5th day of March, 2024

Consent Agenda Item: [] YES [X] NO

Fiscal Impact: [] None [X] Budgeted Expenditure [] Not Budgeted

Vote Required: Majority = X 2/3 Majority = 3/4 Majority =

The County Board has the legal authority to adopt: Yes X No as reviewed by the Corporation Counsel, [Signature], Date: 03.13.2024

Offered and passage moved by:

[Signature] Chair, Timothy McCumber [X] Aye [] Nay [] Abstain [] Absent

[Signature] Vice-Chair John Deitrich [X] Aye [] Nay [] Abstain [] Absent

Supervisor Carl Gruber [] Aye [] Nay [] Abstain [] Absent

[Signature] Supervisor Brian Peper [X] Aye [] Nay [] Abstain [] Absent

Supervisor Marty Krueger [] Aye [] Nay [] Abstain [] Absent

Fiscal Note: Federal Grant funds of \$25,641.66 (75%) have been previously approved to fund update to Sauk County's Hazard Mitigation Plan. In-kind match of 2024 budget will be used to meet the County's responsibility in the amount of \$8,547.22 (25%) for a total expenditure of \$34,188.88.

[Signature]

55 MIS Note: No MIS Note.

Public Participation Plan Sauk County Multijurisdictional 2024 Hazards Mitigation Plan Update

Working in concert with local jurisdictions, Sauk County has initiated a project to update its countywide hazards mitigation plan to comply with the Disaster Mitigation Act of 2000. The items listed below are the ways in which the county will facilitate public participation and local government involvement in the preparation, review, and adoption of the plan update.

- **Formation of a Steering Committee.** An advisory steering committee will be established to guide the project and provide oversight and input. Members, selected by Sauk County Emergency Management, will include county officials and staff, local government officials, emergency services, community members and representatives who wish to participate.
- **Public Notices for Steering Committee Meetings.** All steering committee meetings will be formally noticed and open to the public consistent with the state's open meeting law.
- **Local Government Involvement.** Each of the local governments in Sauk County will be contacted early in the process and informed about the project and asked to enter into a memorandum of understanding (MOU) with the county. Although the MOU would be non-binding, it would establish a framework for intergovernmental cooperation and coordination in terms of information sharing and give the jurisdiction the opportunity to also adopt the plan making it eligible for federal mitigation funding.
- **Local Jurisdiction Survey.** A listing of critical facilities in the jurisdiction and a draft version of the assessment matrix used in the plan will be sent to each of the local jurisdictions in the county. Local officials will have an opportunity to review and comment on the materials prepared up to that date.
- **Fire Chiefs Survey.** A survey will be sent to each of the fire chiefs in the county to collect information on wildland fire in their jurisdiction.
- **Website.** Information about the project will be posted on the county's website, along with draft documents, maps, meeting notices and agendas, and project-related news.
- **Material Availability.** As various drafts are completed, copies will be sent to each of the local jurisdictions in Sauk County and other interested parties for review and comment. Drafts will also be posted on the county's website.
- **Plan Adoption.** The County Board will review the plan at one of its meetings and take final action on the resolution adopting the plan. Each of the participating cities and villages who want to adopt the plan may also adopt resolutions of adoption as well.
- **Press Releases.** Press releases will be issued to the local media on an as-needed basis.
- **Other Means.** The county may provide other avenues for public participation and local government involvement during the course of the project.

RESOLUTION # 21-2024

Resolution Authorizing the Acquisition of a Learning Management System from TalentLMS

Resolution offered by the Personnel and Executive and Legislative Committees.

Resolved by the Board of Supervisors of Sauk County, Wisconsin:

BACKGROUND: Sauk County currently employs roughly 700 employees, plus contractors and elected officials. Providing comprehensive, consistent, and compliant training for this staff is a continuing challenge. A Learning Management System (LMS) provides a software platform that can deliver training courses to staff electronically. This ensures all staff receive the required training in a timely manner while providing the necessary management and regulatory compliance records. Additionally, this will help support the County in a new initiative to increase employee recruitment and retention (a top priority of the County Board based on 2023 survey results).

During the latter half of 2023, Sauk County reviewed numerous LMS options. The field of options was reduced to three specific vendors and, following demonstrations of each, it was determined that the system from TalentLMS best met the specific requirements of Sauk County.

NOW THEREFORE, BE IT RESOLVED, by the Sauk County Board of Supervisors, that the acquisition of licensing for TalentLMS at an annual cost of \$14,970 be hereby approved; and,

BE IT FURTHER RESOLVED, that the Sauk County MIS Director is delegated the authority to enter into any agreements related to the purchase of said system on behalf of Sauk County.

Approved for presentation to the County Board by the Sauk County Personnel and Executive and Legislative Committees, this 19th day of March, 2024.

Consent Agenda Item: [] YES [X] NO

Fiscal Impact: [] None [X] Budgeted Expenditure [] Not Budgeted

Vote Required: Majority = X 2/3 Majority = 3/4 Majority =

The County Board has the legal authority to adopt: Yes X No as reviewed by the Corporation Counsel, [Signature], Date: 03.13.2024.

Offered and passage moved by:

Executive and Legislative Committee:

[Signature] Aye [] Nay [] Abstain [] Absent
Timothy McCumber
[Signature] Aye [] Nay [] Abstain [] Absent
John M. Dietrich
[Signature] Aye [] Nay [] Abstain [] Absent
Brian L. Peper

52
53
54
55
56
57
58
59
60
61
62
63
64
65
66
67
68
69
70
71
72
73
74
75
76
77
78
79
80
81
82
83
84
85
86
87

Carl Gruber Aye Nay Abstain Absent

Marty Krueger Aye Nay Abstain Absent

Personnel and Insurance Committee:

Carl Gruber Aye Nay Abstain Absent



Peter Kinsman Aye Nay Abstain Absent



Terry Spencer Aye Nay Abstain Absent

Robert Prosser Aye Nay Abstain Absent



Jacob Roxen Aye Nay Abstain Absent

Fiscal Note:

The 2024 MIS Budget for Human Resources contains \$12,000 for the implementation of an LMS. Additional funds will be derived from carryforward funds available in MIS Capital Outlay Accounts. Subsequent annual renewal costs will be provided in the MIS budget for Human Resources from tax levy. 

MIS Note:

The proposed system is cloud-based and does not require the purchase of additional hardware or infrastructure to support system operation.

LMS Options											
Functions / Features											
Vendor	Authoring Tool	Course Creation	Course Catalog Included	Single Sign-On	Custom Reports	Custom Homepages	Saves History	AI Capabilities to Create Courses	Translation	Search Functionality	Annual Cost
iSpring	X		X	X	X		X	X	52 languages	X	\$ 23,000
KPA		unlimited		X	X		X		127 languages	X	\$ 19,000
Talent LMS	X	unlimited	750 courses	X	X	X	X	X	Spanish	X	\$ 14,970

RESOLUTION # 22-2024

Resolution to Authorize the Director of Land Resources and Environment to Accept Multi-Discharge Variance Funding; and Amending the 2024 Budget

Resolution offered by the Land Resources and Environment Committee and Finance Committee

Resolved by the Board of Supervisors of Sauk County, Wisconsin:

BACKGROUND: The Multi-Discharge Variance (MDV) program for phosphorus extends the timeline for Wisconsin Pollutant Discharge Elimination System (WPDES) permitted facilities complying with low-level phosphorus limits. In exchange, facilities commit to step reductions of phosphorus within their effluent and provide funding to address nonpoint sources of phosphorus from farm fields or other natural areas through the implementation of practices designed to improve water quality. Sauk County Land Resources and Environment Department can assist in the implementation of these practices.

In December 2023, the department submitted the paperwork necessary to participate in the MDV program and accept funding per Sauk County Resolution No. 94-2023. Actual funding amounts did not become available until January 1, 2024. The original MDV funding amount was anticipated to be \$22,951; however, finalized funding amounts are now \$144,642.17.

THEREFORE, BE IT RESOLVED, by the Sauk County Board of Supervisors, met in regular session, to authorize the Director of Land Resources and Environment to accept multi-discharge variance funding and to:

- Submit watershed plans, annual reports, and other documentation required by the MDV Program to the State of Wisconsin Department of Natural Resources; and
• Enter into cost-sharing agreement with landowners/operators to install best management practices utilizing MDV funding.

BE IT FURTHER RESOLVED, by the Sauk County Board of Supervisors that the 2024 Budget be amended to increase the Multi-Discharge Variance expenditure funded by municipal wastewater treatment facilities.

Approved for presentation to the County Board by the Land Resources and Environment Committee and Finance Committee, this 19th day of March 2024.

Consent Agenda Item: [] YES [] NO

Fiscal Impact: [] None [X] Budgeted Expenditure [] Not Budgeted

Vote Required: Majority = X 2/3 Majority = 3/4 Majority =

The County Board has the legal authority to adopt: Yes X No as reviewed by the Corporation Counsel, [Signature], Date:

03.13.2024

Offered and passage moved by: Land Resources and Environment

52
53
54
55
56
57
58
59
60
61
62
63
64
65
66
67
68
69
70
71
72
73
74
75
76
77
78
79
80
81
82
83
84
85
86
87
88
89
90
91
92
93
94
95
96
97
98

Marty Krueger, Chair

Aye Nay Abstain Absent

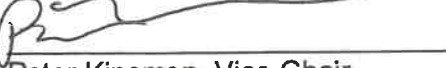
Peter Kinsman, Vice Chair

Aye Nay Abstain Absent

Brandon Lohr

Aye Nay Abstain Absent

Dennis Polivka

Aye Nay Abstain Absent

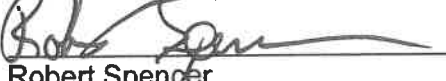
Robert Spencer

Aye Nay Abstain Absent

Valerie McAuliffe

Aye Nay Abstain Absent

Lynn Eberl

Aye Nay Abstain Absent

Randy Puttkamer

Aye Nay Abstain Absent

Finance Committee

Marty Krueger, Chair

Aye Nay Abstain Absent

Thomas Dorner

Aye Nay Abstain Absent

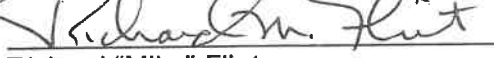
Richard "Mike" Flint

Aye Nay Abstain Absent

Lynn Eberl

Aye Nay Abstain Absent

Tim McCumber

Aye Nay Abstain Absent

Fiscal Note: The 2024 LRE Department Budget did include funding for the MDV program in the amount of \$22,951. As noted, an additional \$121,691.17 is anticipated through the MDV program for Sauk County. 

MIS Note: No information systems impact.

RESOLUTION # 23-2024

Resolution Authorizing to contract with Omni Technologies for the upgrade of the current Sauk County fire alarm monitoring software and to Amend the 2024 Building Services Capital Outlay budget

Resolution offered by the Property Committee and Finance Committee

BACKGROUND: Sauk County Building Services uses the Sauk County dispatch center to monitor any fire alarms that come from the fire panels at the various county buildings. The dispatch center currently monitors four (4) fire alarm panels using Fike Precise fire alarm monitoring software. The Fike Precise software is no longer supported, and updated versions of the software have not been available for several years. With the construction of the Reedsburg and Baraboo Highway facilities wrapping up in 2024, both buildings will need to be monitored. Sauk County dispatch will be providing that monitoring as well. Edwards FireWorks software will be the new software being implemented. The non-budgeted project came in at a cost of \$34,285.00. Building Services is asking to also amend the current 2024 Building Services Capital Outlay budget to add \$34,285.00 of American Rescue Plan Act (ARPA) dollars to cover the cost of the upgrade to FireWorks monitoring software.

THEREFORE, BE IT RESOLVED THAT, the Sauk County Board of Supervisors, met in regular session, hereby authorizes the County Administrator to sign a contract with Omni Technologies to upgrade current Sauk County fire alarm monitoring software to FireWorks at a cost of \$34,285.00.

BE IT FURTHER RESOLVED, that the 2024 Budget is amended to increase the 2024 Building Services Capital Outlay Budget to add \$34,285.00 of American Rescue Plan Act (ARPA) dollars to cover the cost of the upgrade to FireWorks monitoring software.

Approved for presentation to the County Board by the Property Committee & Finance Committee, this 19th day of March 2024.

Consent Agenda Item: [] YES [X] NO

Fiscal Impact: [] None [] Budgeted Expenditure [X] Not Budgeted

Vote Required: Majority = 3/5 2/3 Majority = X 3/4 Majority = _____

The County Board has the legal authority to adopt: Yes X No _____ as reviewed by the Corporation Counsel, [Signature], Date: 03.13.2024

Offered and passage moved by **Property Committee:**

[Signature] Aye Nay Abstain Absent
Carl Gruber

[Signature] Aye Nay Abstain Absent
Mark "Smooth" Detter

[Signature] Aye Nay Abstain Absent
Joel Chrisler

[Signature] Aye Nay Abstain Absent
Robert Spencer

[Signature] Aye Nay Abstain Absent
Jim Astle

57 **Finance Committee:**

58 _____ Aye Nay Abstain Absent

60 Martin F. Krueger

61 _____ Aye Nay Abstain Absent

63 Lynn Eberl

64 _____ Aye Nay Abstain Absent

66 Timothy McCumber

67 _____ Aye Nay Abstain Absent

69 Thomas Dorner

70 _____ Aye Nay Abstain Absent

72 Richard "Mike" Flint

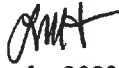
73
74 **Fiscal Note:** The FireWorks software is to be completed in 2024. \$34,285.00 of ARPA funds will be
75 added to the Building Services capital projects 2024 budget to complete the project. 

76
77 **MIS Note:** A replacement computer to run the FireWorks software was purchased in the 2023 Building
78 Services budget.

RESOLUTION # 24 - 2024

Resolution Authorizing the Elected Officials (County Clerk, Register of Deeds, and Treasurer) Salaries for the 2025-2028 Term of Office

Resolution offered by the Finance and Personnel and Insurance Committees

Resolved by the Board of Supervisors of Sauk County, Wisconsin:

BACKGROUND:

In accordance with 59.22 of the Wisconsin Statutes, the total annual compensation for elected officials (County Clerk, Register of Deeds, and Treasurer) for the ensuing term of office must be established prior to the earliest time for filing nomination papers. The Finance and Personnel and Insurance Committees have reviewed the current salaries for Sauk County's elected officials and believe it to be consistent with the personnel and finance policies of the County to recommend the salaries as identified below.

THEREFORE, BE IT RESOLVED, by the Sauk County Board of Supervisors, met in regular session, to establish the elected officials' salaries to be as follows effective the first Monday of 2025:

Table with 6 columns: Elected Position, Current, 2025, 2026, 2027, 2028. Rows include County Clerk, Register of Deeds, and Treasurer with corresponding salary values.

BE IT FURTHER RESOLVED, that the aforementioned county elected officials are entitled to participate in the Wisconsin Retirement System in accordance with the law and the County shall pay the share of contributions required by law, and the official shall make any contribution as required by law; and,

BE IT FURTHER RESOLVED, that the aforementioned county elected officials entitled to participate in the benefits program subject to the terms and conditions of the program, which may be modified from time to time, under the same terms and conditions as coverage offered to other employee groups.

Approved for presentation to the County Board by the Finance and Personnel and Insurance Committees, this 19th day of March, 2024

Consent Agenda Item: [] YES [] NO

Fiscal Impact: [] None [] Budgeted Expenditure [] Not Budgeted

Vote Required: Majority = _____ 2/3 Majority = _____ 3/4 Majority = _____

The County Board has the legal authority to adopt: Yes _____ No _____ as reviewed by the Corporation Counsel, _____, Date:

Offered and passage moved by:

52
53
54
55
56
57
58
59
60
61
62
63
64
65
66
67
68
69
70
71
72
73
74
75
76
77
78
79
80
81
82
83
84
85
86
87
88
89
90
91
92
93

Finance Committee

Supervisor Marty Krueger Aye Nay Abstain Absent

Supervisor Tom Dorner Aye Nay Abstain Absent

Supervisor Lynn Eberl Aye Nay Abstain Absent

Supervisor Richard "Mike" Flint Aye Nay Abstain Absent

Supervisor Tim McCumber Aye Nay Abstain Absent

Personnel and Insurance Committee

Supervisor Carl Gruber Aye Nay Abstain Absent

Supervisor Terry Spencer Aye Nay Abstain Absent

Supervisor Peter Kinsman Aye Nay Abstain Absent

Supervisor Robert Prosser Aye Nay Abstain Absent

Supervisor Jake Roxen Aye Nay Abstain Absent

Fiscal Note:

This resolution will impact future budgets including 2025, 2026, 2027, and 2028. There is no financial impact to the 2024 budget. *JMT*

Annual salary and percentage increases noted below:

Percentage Salary Changes	2025	2026	2027	2028
County Clerk	9.35%	3.00%	3.00%	3.00%
Register of Deeds	9.35%	3.00%	3.00%	3.00%
Treasurer	9.35%	3.00%	3.00%	3.00%

94
95
96

Excludes impact of change in benefit rates.

97
98 MIS Note:
99 No impact.

RESOLUTION # 25-2024

Resolution to Amend the 2024 Budget for Allocation of American Rescue Plan Act (ARPA) Funds for Squad Special Equipment and Squad Car

Resolution offered by the Law Enforcement and Judiciary Committee and Finance Committee

Resolved by the Board of Supervisors of Sauk County, Wisconsin:

BACKGROUND: The Sheriff's Office would like to equip all squads with new cages, partitions, and lighting as the current equipment is over 15 years old and needs to be modified to fit current vehicle models and air bags. In 2022, ARPA funds were allocated for the radio equipment upgrade and the allocation for special squad equipment was not budgeted. In 2023, funds from the vehicle replacement budget were used to purchase the special squad equipment and the Sheriff's Department was not able to purchase a squad car. The 2024 Sheriff's Budget did not include funding for this project. The pricing for the squad equipment and one squad car is estimated at \$240,000; and American Rescue Plan Funds (ARPA) are available for this project.

THEREFORE, BE IT RESOLVED, that the Sauk County Board of Supervisors, met in regular session, does hereby approve an amendment to the 2024 Budget to allocate \$240,000 for squad equipment upgrade and squad car funded by the ARPA grant.

Approved for presentation to the County Board by the Law Enforcement & Judiciary Committee, this 19th day of March, 2024

Consent Agenda Item: [] YES [X] NO

Fiscal Impact: [] None [X] Budgeted Expenditure [] Not Budgeted

Vote Required: Majority = _____ 2/3 Majority = X 3/4 Majority = _____

The County Board has the legal authority to adopt: Yes _____ No _____ as reviewed by the Corporation Counsel, _____, Date: _____

Offered and passage moved by: Law Enforcement and Judiciary Committee

John Deitrich

[X] Aye [] Nay [] Abstain [] Absent

Kevin Schell

[X] Aye [] Nay [] Abstain [] Absent

David Clemens

[X] Aye [] Nay [] Abstain [] Absent

52
53
54
55
56
57
58
59
60
61
62
63
64
65
66
67
68
69
70
71
72
73
74
75
76
77
78
79



Sheila Carver

Aye Nay Abstain Absent

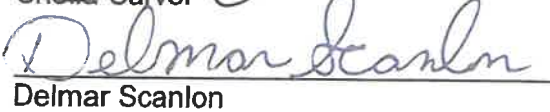

Delmar Scanlon

Aye Nay Abstain Absent

Offered and passage moved by: Finance Committee

Marty Krueger

Aye Nay Abstain Absent

Thomas Dorner

Aye Nay Abstain Absent

Lynn Eberl

Aye Nay Abstain Absent

Richard "Mike" Flint

Aye Nay Abstain Absent

Tim McCumber

Aye Nay Abstain Absent

Fiscal Note: ARPA funding is available for this project, the 2024 budget shall be amended to include an additional \$240,000 of ARPA funding for squad equipment upgrade and squad.

MIS Note: No MIS impact.

RESOLUTION # 26-2024

Resolution to Authorize Sauk County Sheriff's Office to Enter into a Contract Agreement with Southern Health Partners to Oversee and Provide Licensed Healthcare Services for Jail Inmates

Resolution offered by the Law Enforcement and Judiciary Committee

Resolved by the Board of Supervisors of Sauk County, Wisconsin:

BACKGROUND: The Sheriff's Office is charged with the responsibility for administering, managing, and supervising the health care delivery system of the Sauk County Jail under Department of Corrections Code 350.09. The Sheriff's Office solicited bids from medical healthcare providers to provide on-site health care personnel, direct medical services for inmates, and coordination of off-site medical care, hospitalization, dental and other services that may be needed. The Sheriff's Office received two (2) competitive sealed bids for medical services in the Jail based on an average daily population of 129, and the public opening of bids took place on January 25, 2024, at the Sauk County Law Enforcement Center, and the lowest responsible bidder is Southern Health Partners. It is in the best interest of Sauk County to enter into a contract for a stipulated sum of \$522,120 for year one (1) with an annual increase of 4% or Medical CPI (Consumer Price Index), whichever is higher, with Southern Health Partners for the medical services in the Sauk County Jail. Southern Health Partners will be able to provide physicians and registered nurse in the Jail and will:

- Provide 24 hours/day, 7 days/week, 365 days/year consultation with Sauk County Jail Staff when healthcare staff is not present at the facility;
• Provide 112 hours a week of registered nurse services in the Jail to provide medical care to include direct medical services for inmates, coordination of off-site medical care, hospitalization, dental, and other services that may be needed, and oversight of all inmate medications within the Jail;
• Provide expertise in health care provision for the specialized inmate population;
• Provide insurance coverage to defend medical practice in any potential civil litigation against the County of Sauk and/or the Sauk County Sheriff's Office.

THEREFORE, BE IT RESOLVED, by the Sauk County Board of Supervisors, met in regular session, that the lowest responsible bidder of Southern Health Partners in the amount of \$522,120 is hereby accepted by Sauk County for medical services in the jail and the Sauk County Sheriff is authorized to sign a contract for year one (1) with an annual increase of 4% or Medical CPI, whichever is higher, on behalf of Sauk County.

Approved for presentation to the County Board by the Law Enforcement and Judiciary Committee, this 19th day of March, 2024

Consent Agenda Item: [] YES [X] NO

Fiscal Impact: [] None [X] Budgeted Expenditure [] Not Budgeted

Vote Required: Majority = X 2/3 Majority = 3/4 Majority =

51
52
53
54
55
56
57
58
59
60
61
62
63
64
65
66
67
68
69
70
71
72
73
74
75
76
77

The County Board has the legal authority to adopt: Yes X No _____ as reviewed
by the Corporation Counsel, [Signature], Date:
03-14-2024

Offered and passage moved by:

- _____
John Deitrich Aye Nay Abstain Absent
- _____
Kevin Schell Aye Nay Abstain Absent
- _____
David Clemens Aye Nay Abstain Absent
- _____
Sheila Carver Aye Nay Abstain Absent
- _____
Delmar Scanlon Aye Nay Abstain Absent

Fiscal Note: The 2024 budget, with carryforward from 2023, includes \$530,999 for the cost of
medical services. [Signature]

MIS Note: No MIS impact.

SAUK COUNTY BOARD OF SUPERVISORS

March 28, 2024

WEST SQUARE BUILDING, 505 BROADWAY, ROOM 326, BARABOO, WI

SPECIAL MEETING: SAUK COUNTY BOARD OF SUPERVISORS

1. Call to Order and Certify Compliance with Open Meeting Law: 5:00 P.M.

2. Roll Call. PRESENT: (27) Roxen, T. Spencer, Eberl, Kinsman, Scanlon, Anderson, Krueger, Flint, Clemens, Prosser, Lombard, Schell, Dorner, Fordham, Astle, Hazard, R. Spencer, Carver, Polivka, Burchill, Peper, Lohr, Gruber, Detter, Chrisler, Deitrich and McCumber.

ABSENT & EXCUSED: (2) Rego and Klitzke. ABSENT: (2) Stehling and McAuliffe.

Staff present: Brent Miller, County Administrator; Brian Desmond, Corporation Counsel; Becky Evert, Sauk County Clerk.

3. Invocation and Pledge of Allegiance. Invocation given by Supervisor Deitrich.

4. Adopt Agenda. MOTION (Schell/Detter). Motion carried **unanimously**.

5. Adopt The Minutes: None.

6. General Consent Agenda Items: None.

7. Scheduled Appearances: None.

8. Public Comment:

- Jean Scolaro, re: Not to approve the sale of the SCHCC.
- Jeff Seering, re: SCHCC.
- Tom Kriegl, re: Nursing home sale.
- Damian Barta, re: County Board Agenda Item – Consideration of offer to purchase SC Health Care Facility.
- Joy Kirkpatrick, re: Consider offers to purchase Health Care Center.
- Elise Patton, re: Sauk County Healthcare Center. County Board Item, Consideration of offer to purchase SC Health Care Facility.
- Carol Waser, re: Agenda Item.
- William Waser, re: Selling Sauk Co Nursing Center.
- Jean E. Berlin, re: Selling of the Sauk County Health Care Center.
- Carie Wagner, re: Sauk County Health Care Center.
- Mimi Wuest, re: County Health Care Center.
- Mary Williams, re: Health Care Center (Proposed Sale).
- Daniel Holzman, re: Health Care Center.
- Chris Stahmer, re: Aging population, county need.

9. Communications:

- Letter from Nathan Johnson, re: Sauk County Health Care Center.
- Letter from Tracey J. Terrazas, re: Sauk County Health Care Center.
- Letter from Sharyl Schlieckau, re: Sauk County Health Care Center.
- E-mail from Carol J. May, re: Sauk County Health Care Center.
- Letter from Joyce Fichtel, re: Sauk County Health Care Center.
- Sauk County Health Care Center Petition – 504 Signatures (Circulator's name not provided).

- 10. **Appointments.** None.
- 11. **Bills.** None.
- 12. **Claims.** None.
- 13. **Elections.** None.
- 14. **Proclamations.** None.
- 15. **Reports – informational, no action required:** None.
- 16. **Unfinished Business.** None.

17. **New Business.**

It is anticipated that the County Board may enter into closed session pursuant to §19.85(1)(e), Wis. Stats., deliberating or negotiating the purchasing of public properties, the investing of public funds, or conducting other specified public business, whenever competitive or bargaining reasons require a closed session - (Topic: Consider offers to purchase the Sauk County Healthcare Center). A roll call vote will be taken to go into closed session and return to open session. Upon return to open session there will be an announcement of action taken in closed session, or action may be taken based on the closed session (NOTE: If the announcement of action taken in closed session would compromise the need for the closed session, the action taken will not be announced. Any action taken in closed session may be announced when the need for the closed session has passed).

Ray Giannini, Marcus & Millichap Real Estate Investment Sale Brokerage, spoke to the process of the sale.

MOTION (Anderson/Eberl) to go into closed session allowing the following to remain:

Ray Giannini, Marcus & Millichap Real Estate Investment Sale Brokerage; Brent Miller, Administrator; Brian Desmond, Corporation Counsel; Becky Evert, Sauk County Clerk and Emma Greenwood, Health Care Center Administrator.

VOTE: AYES: (27) Roxen, T. Spencer, Eberl, Kinsman, Scanlon, Anderson, Krueger, Flint, Clemens, Prosser, Lombard, Schell, Dorner, Fordham, Astle, Hazard, R. Spencer, Carver, Polivka, Burchill, Peper, Lohr, Gruber, Detter, Chrisler, Deitrich and McCumber. NAYS: (0). ABSENT & EXCUSED: (2) Rego and Klitzke. ABSENT: (2) Stehling and McAuliffe. **Motion carried unanimously.**

Closed session began at 5:59 p.m.

Supervisor McAuliffe joined the meeting right as the board went into closed session.

The meeting resumed in open session at 7:47 p.m.

Chair McCumber announced that three (3) proposals to purchase the Sauk County Health Care Center were received. The Board voted 19/9 in favor, to approve and negotiate with one (1) of the proposed buyers. If a final agreement is reached, the purchase will come back to the Board for a vote.

- 18. **Referrals.**
- 19. **New Agenda items (no discussion).** Submit in writing or by e-mail new business items to the County Administrator as soon as possible for Rule III.A. referral.

20. **Adjournment to a date certain:** MOTION (T. Spencer/Peper) to adjourn at 7:50 p.m. **Motion carried unanimously.**

Respectfully submitted,



Rebecca C. Evert
Sauk County Clerk

Minutes Approved: April 16, 2024

State of Wisconsin, County of Sauk: I certify that the above is a true and correct copy of the March 28, 2024 proceedings of the Sauk County Board of Supervisors. /s/Rebecca C. Evert, Sauk County Clerk.

Original documents on file @ Office of the Sauk County Clerk West Square Building, 505 Broadway, Room #144, Baraboo, WI 53913. 608-355-3286.

www.co.sauk.wi.us

These notices may also be found at: <http://www.wisconsinpublicnotices.org/> or <https://www.co.sauk.wi.us/legalnotices>.